

DENON

Hi-Fi Component

SERVICE MANUAL

STEREO CASSETTE TAPE DECK

MODEL DR-M2/M3

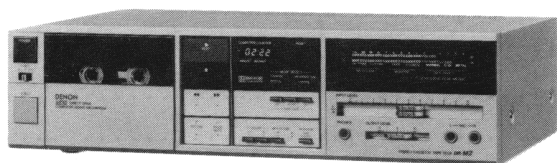

DR-M2

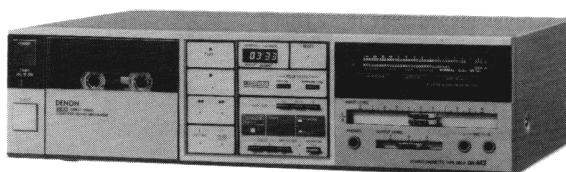

DR-M3

NIPPON COLUMBIA CO., LTD.

TABLE OF CONTENTS

MAIN FEATURES	1
SPECIFICATIONS	2
PART NAMES AND FUNCTIONS	3 ~ 4
BLOCK DIAGRAM (DR-M3)	5
LEVEL DIAGRAM	6
BLOCK DIAGRAM (DR-M2)	7
OUTLINE OF THE MECHANISM CONTROL MICROCOMPUTER	8
DISASSEMBLY INSTRUCTIONS	9 ~ 10
ADJUSTING AND CHECKING THE MECHANISM SECTION	11 ~ 12
ADJUSTING THE ELECTRICAL SECTIONS	13 ~ 16
PARTS LIST OF MECHANISM UNIT	17
PARTS LIST OF EXPLODED VIEW	18
PARTS LIST OF P.W. BOARD	19 ~ 23
EXPLODED VIEW OF MECHANISM UNIT	24
EXPLODED VIEW OF CABINET AND CHASSIS GROUP	25 ~ 26
P.W. BOARD OF KU-0450 AUDIO AMP UNIT	27
P.W. BOARD OF KU-0451 C.T.S. UNIT	28
AND KU-0452 F.L. METER UNIT	
P.W. BOARD OF KU-0449 LOGIC POWER UNIT	29
AND KU-0453 FL COUNTER UNIT	
AND KU-0454 CONTROL UNIT	
P.W. BOARD OF KU-0455 CAPSTAN SERVO UNIT	30
CONNECTIONS OF P.W. BOARD	31
SCHEMATIC DIAGRAM OF AUDIO AMP UNIT	32
SCHEMATIC DIAGRAM OF C.T.S. UNIT	33
SCHEMATIC DIAGRAM OF LOGIC POWER UNIT	34
SCHEMATIC DIAGRAM OF F.L. COUNTER UNIT	35
SCHEMATIC DIAGRAM OF CAPSTAN SERVO UNIT	36
AND CONTROL UNIT	

MAIN FEATURES

- | | |
|--|---|
| 1 Computerized Servo Mechanism | ■ 4-digit tape counter |
| ■ Direct Drive method, eliminating the rubber belt | 4 Automatic tape selector |
| ■ Silent operation with smooth operational feel | 5 Dolby C noise reduction |
| ■ Computer full logic mechanism with high reliability | ■ Double Dolby system |
| 2 3-head system with newly developed SF combination record/playback head | 6 Wide scale 2-color FL peak meter |
| | ■ With automatic peak hold provisions (DR-M3) |
| 3 Computer counter | 7 Computerized Tuning System (DR-M3) |
| ■ Remaining tape time | |

SPECIFICATIONS

Type	Vertical tape loading 4-track 2-channel stereo cassette tape deck
Heads	SF Record/Playback combination head x 1 Double gap ferrite Erase head x 1
Motors	FG servo DD motor (for capstan) x 1 DC motor (for reel winding) x 1
Tape speed	4.8 cm/sec.
Fast forward, rewind time	Approx. 90 sec. with a C-60 cassette tape
Recording Bias	Approx. 105 KHz
Overall S/N ratio (at 3% THD level)	Dolby C ON more than 73 dB (CCIR/ARM)
Overall frequency response	25-21,000 Hz \pm 3 dB (at -20 dB METAL tape)
Frequency range	20-23,000 Hz (at -20dB METAL tape)
Channel separation	More than 40 dB (at 1KHz)
Crosstalk	More than 65 dB (at 1KHz)
Wow & flutter	Less than 0.027% w rms
Input	
microphone	0.35 mV (-67 dB) with input level control at maximum. Input impedance: 10 Kohm unbalanced.
line	77.5 mV with input level control at maximum. Input impedance: 50 Kohm unbalanced.
Output	
line	775 mV (0 dB) with output level control at maximum. (with 10 Kohm load, recorded level of 200 Pwb/mm)
headphone	1.2 mW with output level control at maximum (optimum load impedance 8 ohm - 2 Kohm).
Accessories	Parallel pin cord x 2, cleaning stick set x 1
Power supply	50 Hz/60 Hz compatible Note: The rated supply voltage is preset to match that used in the country of original shipment.
Power consumption	22 W
Dimensions	434 (W) x 115 (H) x 286 (D) (mm)
Weight	5.7Kg

- Above specifications and design styling are subject to change without notice for improvement.
- "Dolby" and the symbol  are the registered trademarks of Dolby Laboratories Licensing Corporation. The Dolby Noise reduction system is licensed by Dolby Laboratories Licensing Corporation.

PART NAMES AND FUNCTIONS

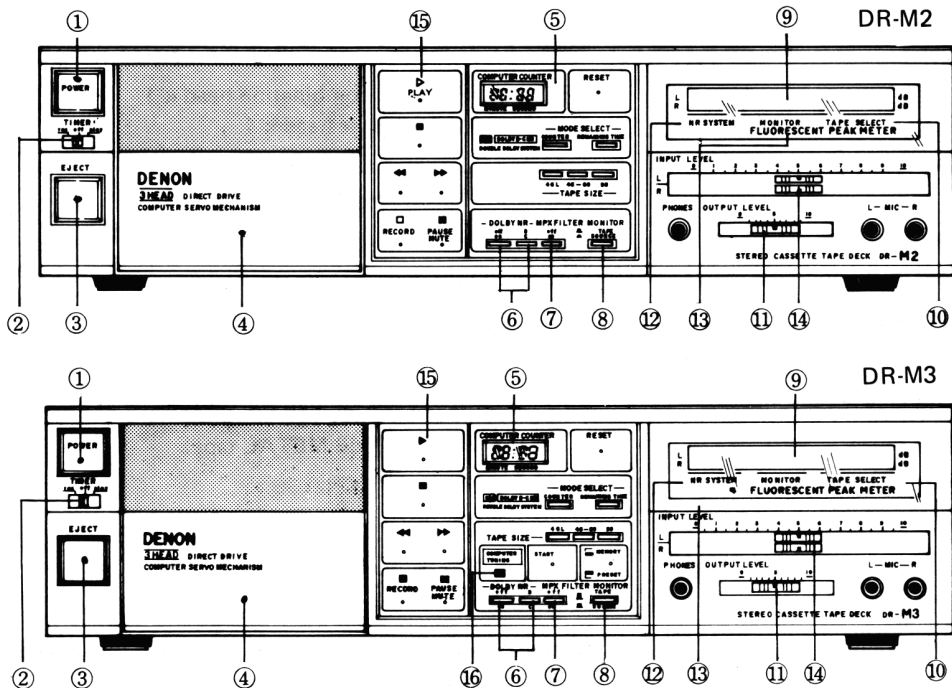

1. Power switch (POWER)

The power of the set is turned ON and OFF. The power is turned on when the switch is pressed. It is turned off when pressed again. The set will not be operated for approximately 4 seconds until the set is stabilized after turning on the power supply.

2. Timer switch (TIMER)

This is used when using an audio timer for 'unattended recordings' or 'wake up playback'. Normally, it is kept off.

3. Eject button (EJECT)

This is pressed to open the cassette compartment. When opening the cassette compartment during operations, press the EJECT button after the ■ STOP key is pressed.

4. Cassette compartment

The cassette tape is loaded here. If it is not closed completely, the control buttons do not function.

5. Computer counter (COMPUTER COUNTER)

The tape counter and the remaining tape time is indicated by the 4-digit display.

6. Dolby noise reduction switch (DOLBY NR)

The left switch turns the DOLBY NR SYSTEM on (—) and off (■). The right switch is used to select either DOLBY-B TYPE (■) or C-TYPE (—).

7. Multiplex filter switch (MPX FILTER)

This switch is turned on (—) when making FM recordings using DOLBY to prevent the mis-operation of the DOLBY NR circuit. Turn the switch off (■) when making recordings other than FM recordings using DOLBY.

8. Monitor switch (MONITOR)

Set this switch to SOURCE (—) when monitoring the sound before it is recorded, such as when setting the recording level; set to TAPE (■) when playing back the tape or monitoring the recorded sound.

9. FL peak meter (FL PEAK METER)

The peak of the recording input level or the playback output level is indicated. An 'automatic peak hold' provision to hold the maximum level for approximately 1.5 seconds above -1dB is built in. (No peak hold provision on the DR-M2)

10. Tape select indicator (TAPE SELECT)

One of the three words 'NORMAL', 'CrO2' or 'METAL' is displayed according to the automatic tape selector, which automatically sets the optimum position when the cassette is loaded into the cassette compartment.

11. Output level knob (OUTPUT)

This adjusts the volume of the headphone as well as the playback/record monitor output.

12. Noise reduction system indicator (NR SYSTEM)

Either 'B-TYPE' or 'C-TYPE' is displayed, according to the DOLBY NR switch.

13. Monitor indicator (MONITOR)

Either 'TAPE' or 'SOURCE' is displayed, according to the MONITOR switch.

14. Record input level knob (INPUT LEVEL)

The record input level is adjusted. The upper knob is for L CH (left channel) and the lower knob is for R CH (right channel).

15. Tape control buttons

PLAY Button

The ▷ PLAY Button is pressed to play back the cassette tape.

STOP Button

The ■ STOP Button is pressed to stop the tape.

REWIND Button

The ◀◀ REW Button is pressed to rewind the tape.

FAST FORWARD Button

The ▶▶ FF Button is pressed to fast forward the tape.

RECORD Button

The □ RECORD and PLAY Buttons are pressed together when making recordings. The set will be in the REC PAUSE (record standby) when only the □ RECORD Button is pressed.

PAUSE/MUTE Button

The PAUSE/MUTE Button is pressed to pause (temporarily stop) the tape during recording or to make a muted (no sound) section.

16. Computerized tuning system (COMPUTER TUNING)

This system automatically adjusts the set to the optimum recording conditions of the tape to be used. (only for DR-M3)

BLOCK DIAGRAM (DR-M3)

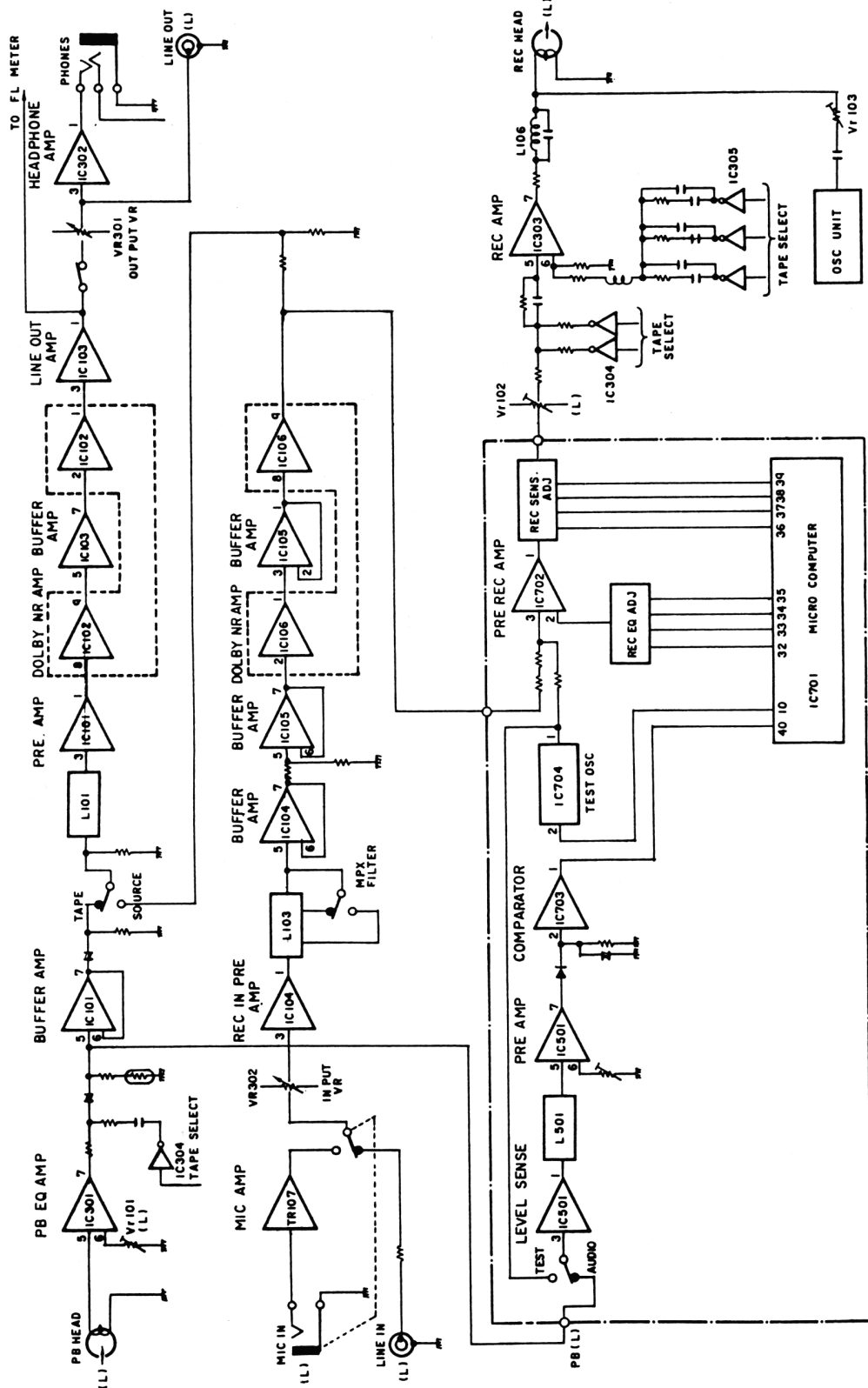

LEVEL DIAGRAM

PLAYBACK SYSTEM

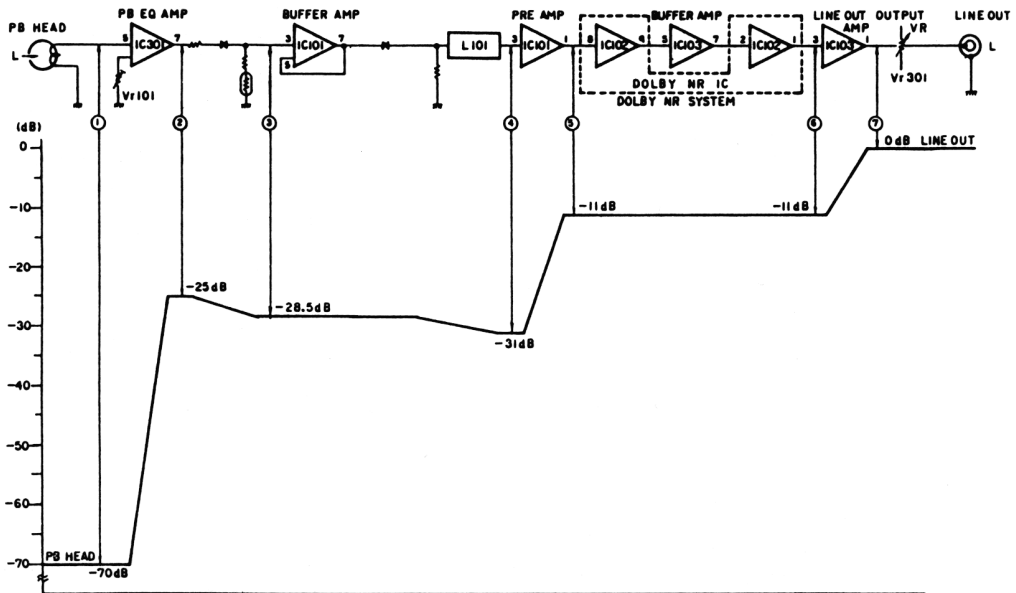

RECORDING SYSTEM

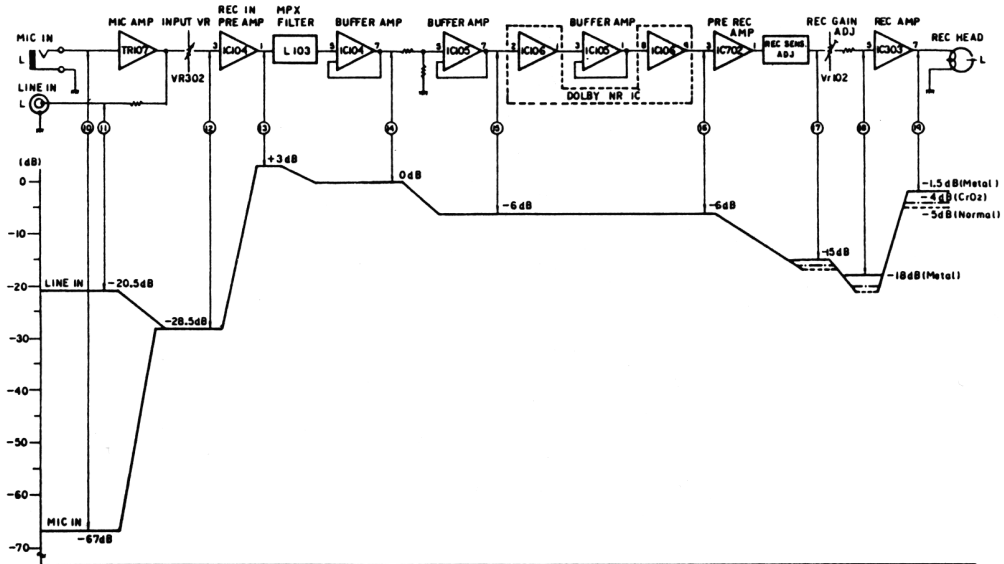

BLOCK DIAGRAM (DR-M2)

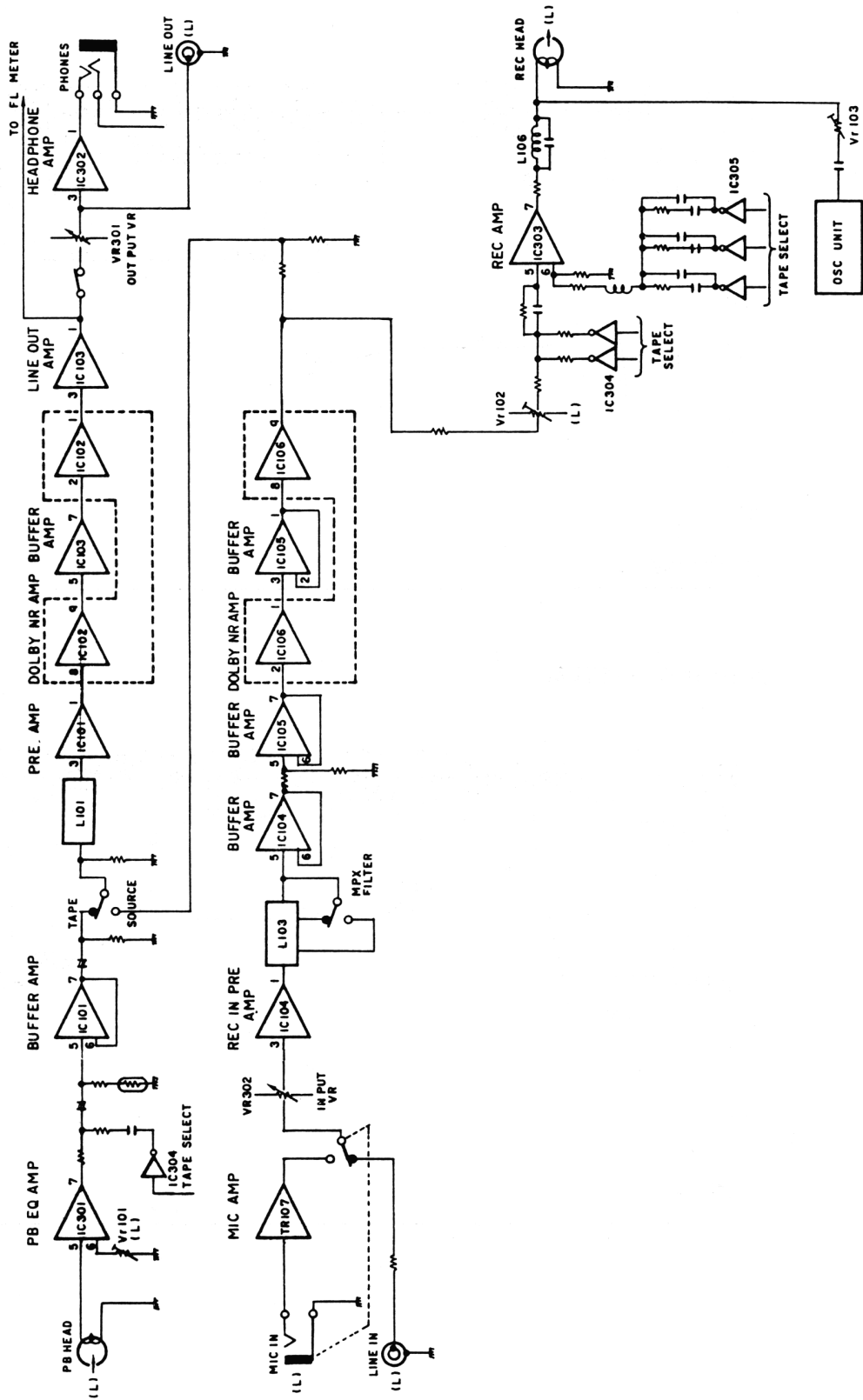

● Outline of the Mechanism Control Microcomputer

The function of the microcomputer, which is applied to the uni-directional transport cam drive control cassette deck mechanism, will receive an outside signal from the operation switch (operations such as PLAY, REC, STOP, FF) during the recognition of the current condition or from the surrounding circuits of the microcomputer (automatic tuning, linear counter, cam encoder, reel pulse, etc.) and sends the appropriate control signal.

To the mechanism: rotational direction of the reel motor, speed, stop, rotational direction of the cam motor, stop.

To the linear counter: makes an output of the mechanism run mode command (REW, FF, PAUSE, PLAY).

To the automatic tuning: REC, P/B, LINE mute signal commands. Makes an output of the BIAS ON/OFF command (CUE command).

To the display: REC, PAUSE (REC MUTE during flash).

In addition, the following points are taken into consideration.

- (1) Stable and accurate cam rotation position control is required since a cam drive method is employed to make the mechanism silent. Accurate rotation position control is performed by using a cam drive with a rotary encoder detected digital feedback servo.
- (2) Since the leading time of the cam drive is slower when compared to that of the plunger method, problems will arise when attempting record/playback or stop at the designated tape position from FF or REW, since tape overrun occurs. This is especially important when controlling the recording from the position where the automatic tuning was completed.
(Erasing the previous music when making recordings after the automatic tuning is completed must be prevented.)
For this, the tape cuing is corrected after the automatic tuning is completed to control the tape position accurately.
- (3) Power outage measures
When the power supply is cut off, the cam of the mechanism shifts to STOP.
- (4) Overload measures of the cam
If the cam stops due to an overload for any reason and cannot shift to the target position within 4 seconds, it is immediately shifted to STOP. If this cannot be shift-

ed within 4 seconds, the microcomputer will stop all controls and stop the motor to prevent a breakdown.

● Computer Counter

This counter employs the computer to automatically calculate and display the remaining tape time using the optical detection method. The remaining tape time is displayed in minute/seconds. Up to 6 minutes remaining, the time is displayed in minute units; after 5 minutes 59 seconds, it automatically shifts the display to minutes/seconds.

The method used for detecting the remaining time is the optical detection method, which uses LEDs and infra-red sensors. This system detects the pulse of the hub rotation speed, which varies according to the remaining amount of tape, using the reel mount and the synchronized shutter. The information is sent to a microcomputer which constantly calculates and displays the remaining time. In addition, to keep the remaining time variations caused by differing cassette half hub sizes and tape thicknesses to a minimum, selector switches for (1) C-46 (2) C-46 - C-60 (including C-50) and (3) C-90 are provided.

Since this deck is equipped with an automatic tape selector mechanism, it automatically responds to metal tapes, whose tape thickness is different from other tapes. This counter, aside from the remaining tape display, also functions as a bright, easy to see normal electronic counter, using the selector.

● Computer Tuning (CTS)

This tuning system automatically sets the equalizer and recording sensitivity, both of which are important to maximizing the performance of various tapes and to make high quality recordings. The tuning time is only 5 seconds; recording chances are not missed. When the cassette is loaded, the auto tape selector sets the deck to the standard optimum condition. Strictly speaking, however, the recording sensitivity and frequency characteristics of the tapes vary, depending on its type.

The computer tuning system allows the maximum performance of the tape to be heard and at the same time ideally corrects the frequency characteristics to a flat and wide range characteristic.

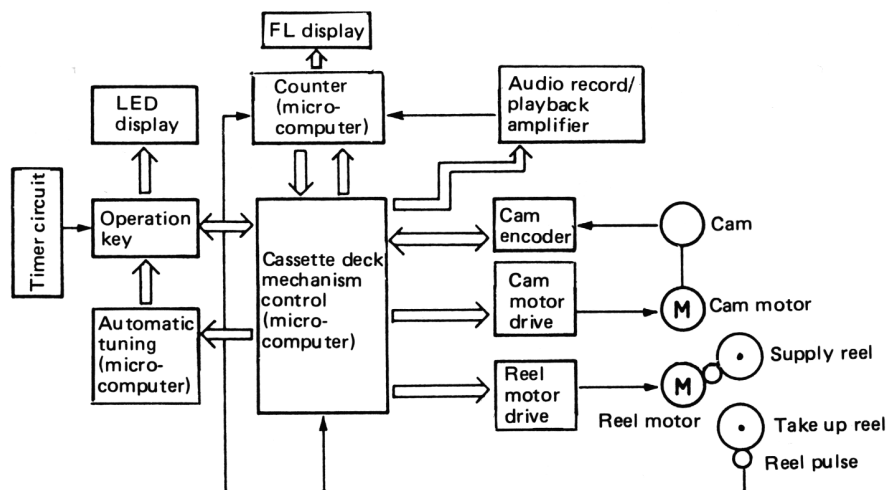

DISASSEMBLY INSTRUCTIONS

1. How to Remove the Front Panel

- (1) Unscrew the 4 screws (4x8 CTTS P tight) 306 from both sides of the top cover 217 and take off the top cover by pulling it up.
- (2) Press the eject knob 204, open the cassette window 206 and take off the mechanism, as shown in the diagram.
Note: Be careful when handling the cassette window, as it is easily scratched.)
- (3) Remove the connector (5P) with lead wires, which runs from the timer switch 243 to the rear of the logic circuit board 241, from the logic circuit board.
- (4) The front panel can be removed by unscrewing the 3 upper screws (3x8 CFTS S tight) 303 from the front panel 202 and the 3 lower screws (3x8 CFTS P tight) 302.

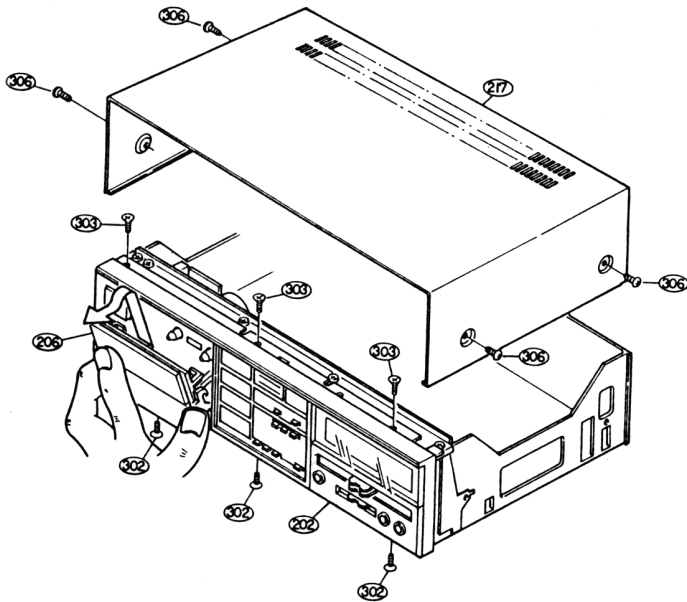

2. How to Remove the Mechanisms

- (1) Remove the top cover 217 and the front panel 202. (Refer to section 1)
- (2) Unscrew the 2 mechanism holding screws (3x6 CBTS S tight) 301 from the bottom surface of the chassis 218.
- (3) Unscrew the 2 screws (3x6 CBTS S tight) 301 holding the angle 233 and the mechanism 201 and the 3 meter frame 223 and chassis holding screws (3x8 CBTS P tight) 304 and remove the angle.
- (4) Remove the connectors with lead wires, which runs from the mechanism section, from the circuit board.

Audio circuit board side	2P connector CN101 CN201
	3P connector CN302
	4P connector CN301 CN303
Logic circuit board side	2P connector CN12 CN13
	4P connector CN6 CN9
	5P connector CN10
	6P connector CN11

Note: When assembling, check to make sure the connectors are inserted correctly.

- (5) Pull out the power switch lever 234 from the power switch 245.
- (6) The mechanism can be removed by holding the mechanism and pulling up.

Note: When assembling, do so after checking to make sure the 2 stay holes on the lower side of the mechanism unit are matched with the chassis protrusions.

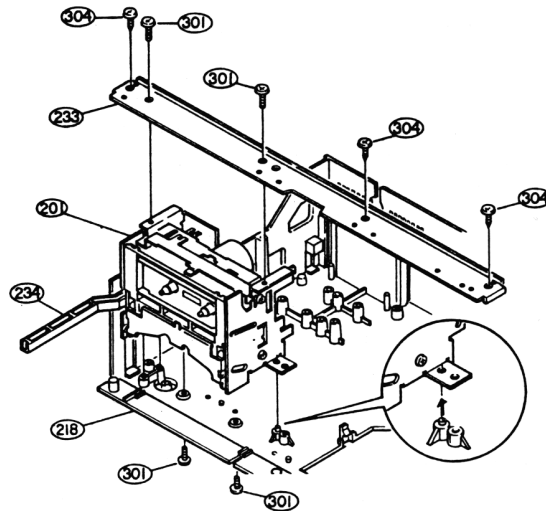

3. How to Remove the Control Circuit Board

- (1) Remove the top cover 217 and the front panel 202. (Refer to section 1)
- (2) Using a small minus screwdriver, loosen the 2 hooks on one side of the meter frame 223 which holds the control cover 207 and remove the control cover.
- (3) Remove the connectors with lead wires which run from the control circuit board 258.

FL counter circuit board side	6P connector CN403
Logic circuit board side	8P connector CN1
	4P connector CN2
CTS circuit board side	8P connector CN701
	(only for DR-M3)
- (4) By unscrewing 3 screw (3x8 CBTS P tight) 304 holding the control circuit board and loosening the 3 hooks on the left side of the meter frame, the control circuit board 258 can be removed.

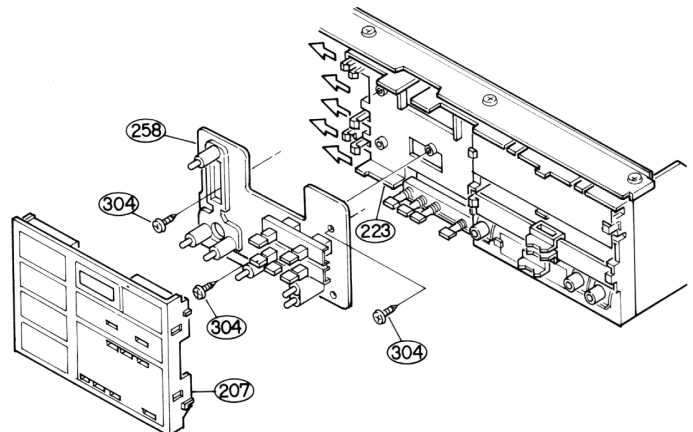

Note: When replacing the tight switch 261, always check to make sure that it is not floating above the circuit board. If it is floating, the switch will be in the on condition when the set is assembled.

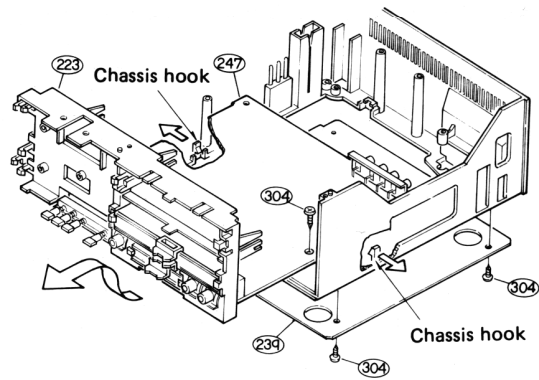
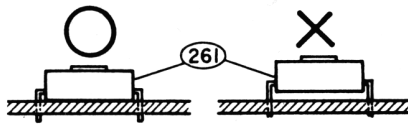

4. How to Remove the FL Meter

- (1) Remove the top cover 217 and the front panel 202. (Refer to section 1)
- (2) Remove the 12P and 4P connectors on the FL meter circuit board 256.
- (3) By loosening the left/right hooks on the meter frame 223, which holds the FL meter, the color filter 225 and the FL meter can be removed together with the circuit board.

Note: The FL tubes are glass, be careful when handling.

5. How to Remove the FL Counter

- (1) Remove the top cover 217 and the front panel 202. (Refer to section 1)
- (2) Remove the 2P, 6P and 9P connectors from the FL counter circuit board 257.
- (3) By unscrewing the 2 screws (3x6 CBS) 308 on the upper section of the FL counter, the FL counter can be taken out towards the back, together with the circuit board.

Note: The FL tubes are glass, be careful when handling.

6. How to Remove the CTS Circuit Board (only for DR-M3)

- (1) Remove the top cover 217. (Refer to section 1)
- (2) The CTS circuit board 255 can be removed upwards by pulling it upwards and loosening the 2 hooks on the chassis 218.

7. How to Remove the Audio Circuit Board

- (1) Remove the top cover 217 and the front panel 202. (Refer to section 1)
- (2) Unscrew the lower screw 301 holding the mechanism and the chassis. (Refer to section 2)
- (3) Remove the angle 233. (Refer to section 2)
- (4) Remove the control circuit board 258, FL meter 256 and the FL counter 257. (Refer to sections 3, 4, 5)
- (5) Remove the connectors from the audio circuit board 247.
- (6) Remove the CTS circuit board 255. (Refer to section 6)
- (7) Unscrew the 2 bottom cover holding screws (3x8 CBTS P tight) 304 on the back side of the chassis and remove the bottom cover 239.
- (8) By lifting the meter frame 223 and loosening the 2 hooks on the chassis holding the audio circuit board 247, the audio circuit board can be removed.

When Separating the Audio Circuit Board by Itself

- (9) Remove the mask sheet 226 from the meter frame.
- (10) Loosen the hook on the left side of the meter frame holding the longer rail 213 and remove the guide rail together with the knob 215.
- (11) Unscrew the 2 screws (2.6x5 CBS) 307 holding the input volume 254 and loosen the 2 rear hooks and remove the input volume toward the rear.
- (12) Loosen the hook on the right side of the meter frame holding the shorter guide rail 214 and remove the guide rail together with the knob 215.
- (13) Unscrew the 2 screws (3x6 CBS) 308 holding the output volume 248.
- (14) Pull down the steel mounts holding the microphone jack 249 and the headphone jack 250.
- (15) By removing the meter frame 223, the audio circuit board can be removed by itself.

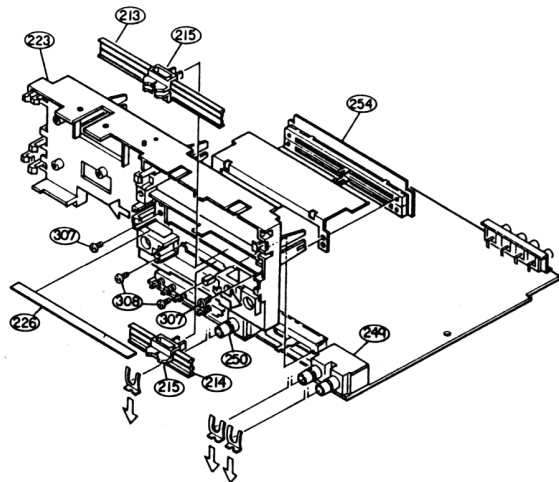

Note: Most repairs to the audio circuit board can be performed by removing the bottom cover on the chassis. Refer to the above procedure only when necessary.

When reassembling, follow the procedures in reverse order; however, if each of the various parts are not assembled properly in their respective positions, the set cannot be assembled. When assembling, check the work of each step carefully.

8. How to Remove the Logic Circuit Board

- (1) Remove the top cover 217. (Refer to section 1)
- (2) Remove the CTS circuit board 255. (Refer to section 6) (only for DR-M3)
- (3) Remove the various connectors from the logic circuit board 241.
- (4) Unscrew the 4 screws (3x8 CBTS P tight) 304 holding the logic circuit board.
- (5) Pull the logic circuit board 241 forward until the remote jack 242 is disconnected from the rear of the chassis 218; it can then be removed.

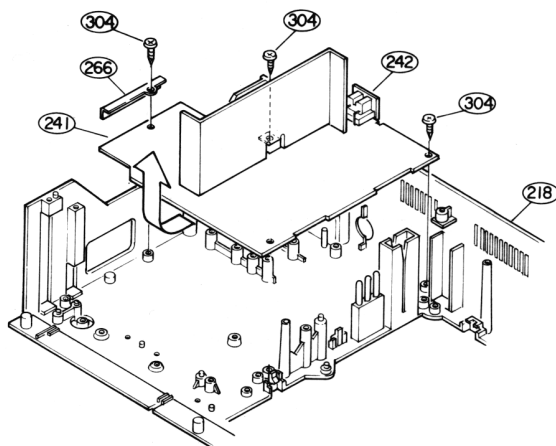

9. How to Remove the Power Supply Circuit Board

- (1) Remove the top cover 217. (Refer to section 1)
- (2) Unscrew the 1 screw (3x8 CBTS P tight) 304 holding the bracket 221 of the power supply circuit board 244.
- (3) By pulling the power switch lever 234 out of the power supply switch, the power supply circuit board can be removed upwards.

ADJUSTING AND CHECKING THE MECHANISM SECTION

1. Replacing the Pinch Roller 23

Before replacing the pinch roller, clean the tape contact surface of the pinch roller and the capstan shaft.

Most causes of poor tape transport can be traced to dirty pinch rollers and capstan shafts.

The pinch roller 23 can be removed by removing the spring 24 and the slit washer 317.

After replacing, run a padless C-90 tape to check for tape curls at the tape guide section of the head.

2. Checking the Pressure Force of the Pinch Roller

In the playback mode, hook a spring weight onto the bracket at the center of the pinch roller. After separating the pinch roller from the capstan shaft, allow the pinch roller to contact the capstan shaft again. Check to make sure the spring weight reads between 350–450g when the pinch roller starts to rotate. If it is not within the normal range, replace the pinch roller spring 24.

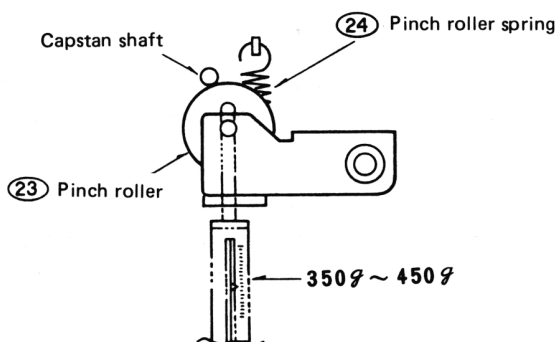

3. Replacing the Record/Playback Head

* Before replacing, remove the front panel 202.

(1) How to remove the R/P HEAD.

- 1) Unscrew the recording head holding screw 312.
- 2) Next, take out the azimuth adjustment NUT 311 and the height adjustment ORDER SCREW 10 loosening them alternately.

If they are not loosened alternately, the R/P HEAD base may become warped.

- 3) By unsoldering the HEAD WIRES on the circuit board section of the R/P HEAD, the entire R/P HEAD can be taken off the mechanism unit.

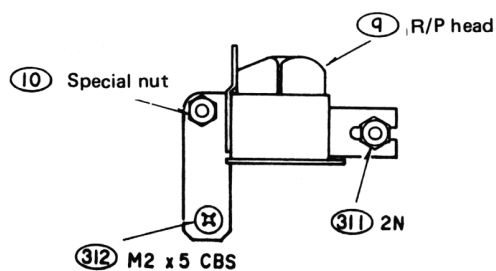

(2) How to assemble the R/P HEAD.

Reverse the above (1) procedures for removing the R/P HEAD.

* Solder the HEAD WIRES according to the diagram above.

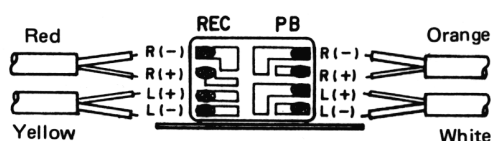

4. Adjusting the R/P HEAD

(1) Height adjustments (Use the head adjusting jig M-300)

Set the M-300 tool plate on the mechanism unit; turn the height adjustment ORDER SCREW 10 and adjust so that the 3.8 mm measure section of the M-300 (tool grip) can pass without contacting the tape guide of the R/P HEAD 9.

- * Only the height adjustment is necessary; no tilt adjustments are required.
- * When adjusting the height, make sure the R/P HEAD is not tilted by turning the azimuth adjustment nut, and checking with your eyes.
- * Never allow the M-300 (tool grip) to hit the tape contact surface of the R/P HEAD strongly. It may scratch the surface.

(2) Azimuth adjustments

Play back the TEAC MTT-114 test tape. Turn the azimuth adjustment nut and adjust so that A of the resurge wave form is maximum and B is minimum. After the azimuth adjustments, re-check the head height with the M-300 to make sure the height has not deviated.

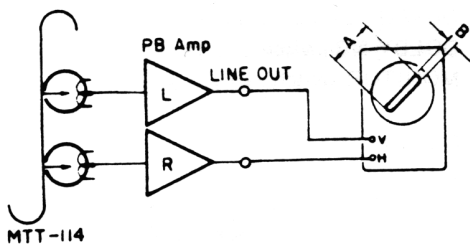

- * After the adjustments, apply anaerobic adhesive on the positions indicated in the diagram.

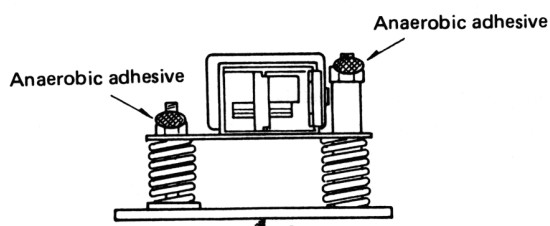

5. Replacing the ERASE HEAD 15

Remove the slit washer 315 holding the tension arm ass'y 17; after removing the tension arm ass'y, unscrew the 2 ERASE HEAD holding screws 31 and replace the ERASE HEAD. When attaching the ERASE HEAD, position it to the lower side.

6. Adjusting the ERASE HEAD Height

Using the head adjusting jig (M-300), turn the height adjustment nut 311 and adjust the height in the same manner as adjusting the R/P HEAD. After the adjustments, apply anaerobic adhesive on the position indicated in the diagram.

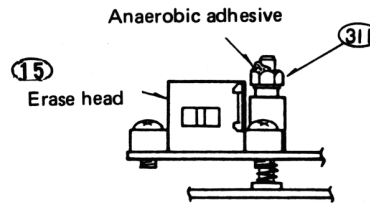

7. Adjusting the Gap Between the Tension Arm Ass'y 17 and Arm Base

Load a cassette tape and place the set in the playback mode. Adjust the adjustment screw 316 so that the gap between the tension arm ass'y and the tension arm base is 0.5 - 0.8 mm. After the adjustments, apply anaerobic adhesive on the position indicated in the diagram.

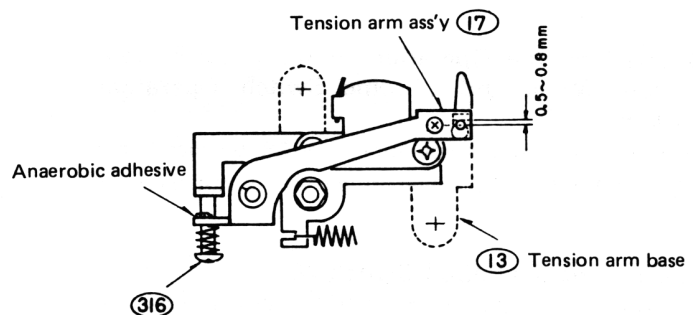

8. Checking for Axis Direction Movements of the Capstan Shaft

Hold the capstan shaft from the front of the mechanism and move it in the axis direction; check to make sure some movement exists.

9. Checking the Take-up Torque

Load the cassette type torque meter. Check to make sure that the torque meter average reading is within 35~65 g-cm during playback. If it is not within this range, check the voltage (5.1 - 5.3V) of the reel motor. If the voltage is low, the torque will be weak; if it is high, the torque will be strong. In addition, check for reel thrust movement in section 10.

10. Adjusting the Reel Thrust Movement

Check to make sure that the reel thrust movement is within 0.2-0.4 mm.

11. Checking the FF and REW Torques

- * When using the cassette type torque meter.
Check to make sure the torque meter indicates more than 70 g-cm at the end of FF and REW.
- * When using a modified cassette half.
Load the modified cassette half; hook the end of the dial tension meter (full scale 100–300 g) onto the triangle section. In the FF (REW) mode, feed the tape in at a rate somewhat slower than the take up speed. Check to make sure the dial tension meter reads more than 60 g-cm.

12. Checking the Back Tension Torque During Record/Playback

Load the cassette type torque meter; check to make sure the torque meter reads between 2–5 g-cm during playback and that there is no unevenness.
If it is not within this range, check the section on adjusting the reel trust movement; or else replace the spring 26.

13. Checking the FF and REW Times

Load a C-60 cassette tape; check to make sure the tape is fast forwarded or rewound within 70–110 seconds. If it is not within this range, check sections 10 and 12.

14. Checking the Operation of the Erase Prevention, Metal and Chrome Switch Operation Arms

Check to make sure the operation arms 58, 59 operate the switches positively, depending on whether or not there are holes.

15. Checking the EJECT Switch 75

To check the operation of the EJECT SW with only the mechanism unit, make sure the hook lever A operates the switch positively when the EJECT lever 64 is operated.

16. Checking the Gap Between the Pulse Detection LED and the Reel Ass'y

Check to make sure the gap between the surface of the shutter section of the reel ass'y and the LEDs is approximately 1 mm.

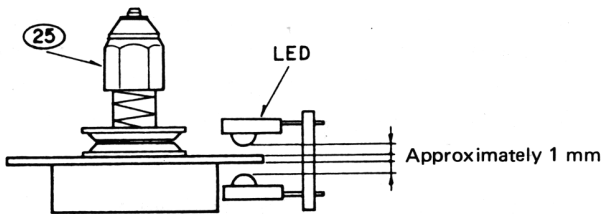

ADJUSTING THE ELECTRICAL SECTIONS

● Measuring instruments necessary for adjustments

- (1) Audio signal generator
- (2) Variable resistance attenuator
- (3) Vacuum tube voltmeter
- (4) Oscilloscope
- (5) Frequency counter
- (6) Adjustment screwdriver
- (7) Trap coil adjustment square stick
- (8) Test tapes (TEAC MTT-111, MTT-114, MTT-150, (A-BEX TCC-262) (DENON DX 3, DXM, DX7/50N, LX)
- (9) Transport Check cassette tape (COLUMBIA C-120, modified)

● Cautions on adjusting

- (1) Before adjusting, clean the head surface, capstan and the pinch roller with a gauze or a cotton swab moistened with alcohol.
- (2) Demagnetize the R/P HEAD and the E. HEAD with a head eraser.
- (3) Completely demagnetize the adjustment screwdriver.
- (4) Unless instructed otherwise, set the various controls as follows:
 - INPUT volume maximum
 - OUTPUT LEVEL volume maximum
 - DOLBY NR switch OFF
 - MONITOR switch TAPE

1. Tape Transport Check

Load the transport check cassette. In the operational mode, illuminate the fixing guides of the R/P HEAD with a lamp and check to make sure the tape edge does not come in contact with the tape guide section.
The tape transport is the most important element in determining the performance of a cassette deck.
Avoid moving the various adjustment screws, nuts, etc., as much as possible. Refer to the pages on "Adjusting and Checking the Mechanism Section" when replacing or adjusting the R/P HEAD.

2. Adjusting the Azimuth

- (1) After completing the tape transport check, load the test tape (TEAC MTT-114).
- (2) Play back the test tape; adjust the azimuth screw so that section A of the resurge wave form is maximum and section B is minimum.

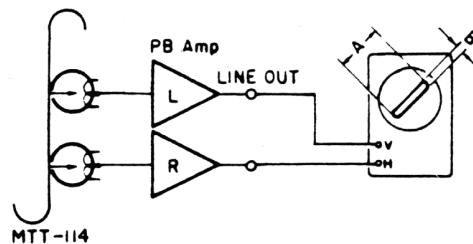

3. Checking and Adjusting the Tape Speed

- 1) Connect the frequency counter to the LINE OUT terminal and load the test tape (TEAC MTT-111).
- 2) Play back the test tape; at the midpoint of the tape, where the transport is stable, adjust VR 901 so that the frequency counter reading is in the range of 3,000 Hz \pm 6Hz.

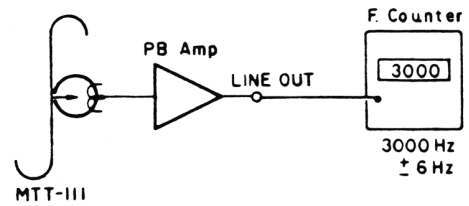

4. Adjusting the Input Sensitivity

- (1) Set the MONITOR switch to SOURCE position, the operational mode at STOP. Supply a 400 Hz signal to the LINE IN terminal and set the input signal level (approx. -20 dB) so that the output level at the LINE OUT TERMINAL (L ch) becomes 0dB.
- (2) At the same time, check to make sure the R ch output level is also 0dB.

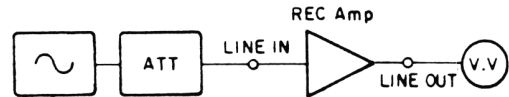

5. Checking the Operation of the DOLBY

Set the MONITOR switch to SOURCE. When a -41dB signal input is made to the LINE IN terminal, check to make sure the output frequency response from the LINE OUT terminal meets the specification in the diagram below.

Dolby C Back to Back Frequency Response

Level : -20dB from Dolby
 Monitor : SOURCE
 Dolby NR : on, C

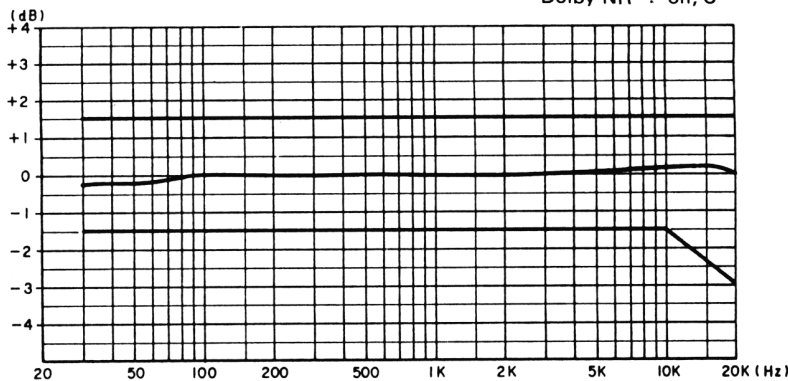

6. Adjusting the Playback Section

- (1) Adjusting the playback level
 Play back the Dolby standard level test tape (TEAC MTT-150) and adjust Vr 101 (L ch), Vr 201 (R ch) so that the LINE OUT voltage becomes 0 dB (0.775 V).
- (2) Adjusting the playback frequency response
 Play back the test tape (A.BEX TCC-262) and (check to make sure that the frequency response meets the specifications in the diagram).

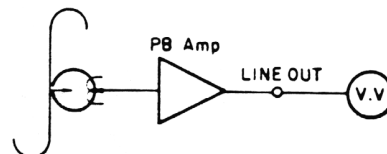

Playback Frequency Response

Tape : A.BEX Tcc-262

When using MTT-316 make corrections along.

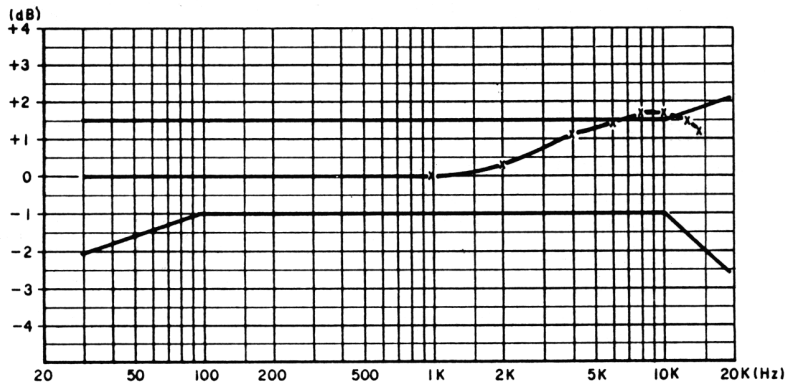

7. Adjusting the FL Meter

After adjusting the playback level, play back the test tape (TEAC MTT-150) and adjust VR 801 (L ch), VR 802 (R ch) so that the FL meter indicates 0dB when the LINE OUT terminal level is 0dB (0.775V).

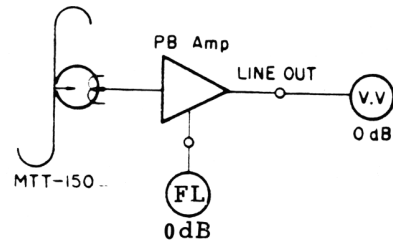

8. Adjusting the Recording Section

(1) Adjusting the record/playback overall frequency response.

- 1) Load the test tape DX7/50N; record a signal with an input level of -41 dB, 1 KHz at the LINE IN terminal; play back this recording.
- 2) Change the frequency of the input signal to 12kHz, record and playback; adjust VR 103 (L ch), VR 302 (R ch) so that the characteristic standards meet the following diagram when compared to the 1kHz signal output level.

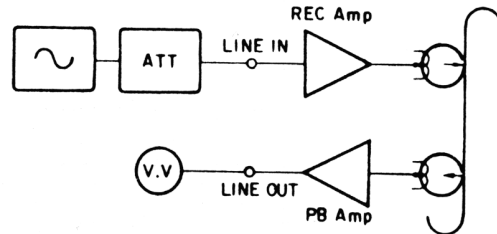

Record/Playback Overall Frequency Response

Tape : DX7N

Dolby : off

Level : -20 dB from Dolby

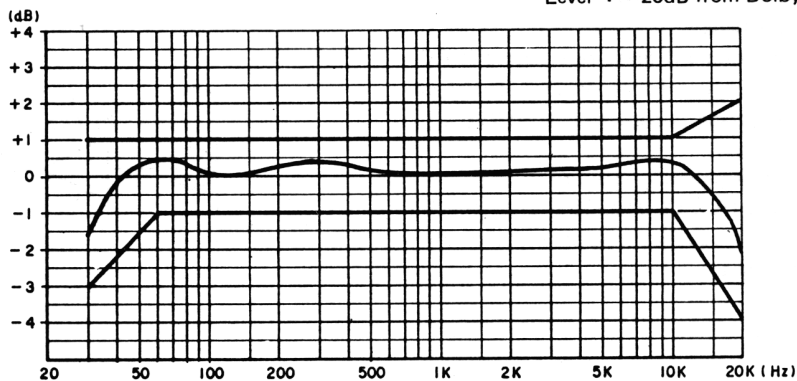

- (2) Adjusting the record/playback levels
- 1) Load the test tape DX7/50N and record a signal of 1 KHz (-41 dB).
 - 2) Adjust Vr 102 (L ch), Vr 202 (R ch) so that the output level is the same when the MONITOR switch is switched from SOURCE to tape position.
- (3) Checking the Dolby C record/playback overall frequency response
- 1) Set the DOLBY NR switch to the "C" position.
 - 2) Using the test tapes DXM, DX7/50N, DX-3, perform record/playback in the same manner as 8-(1).
 - 3) Check to make sure that the record/playback overall frequency response meets the specifications in the diagram.

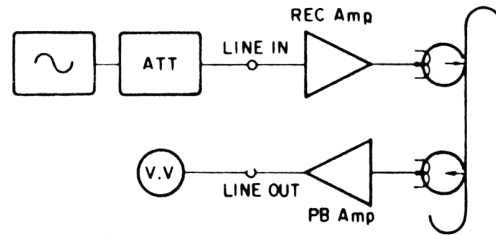

Dolby C Record/Playback Overall Frequency Response.

Tape : DX7N
 Dolby : on, C
 Level : -20dB from Dolby

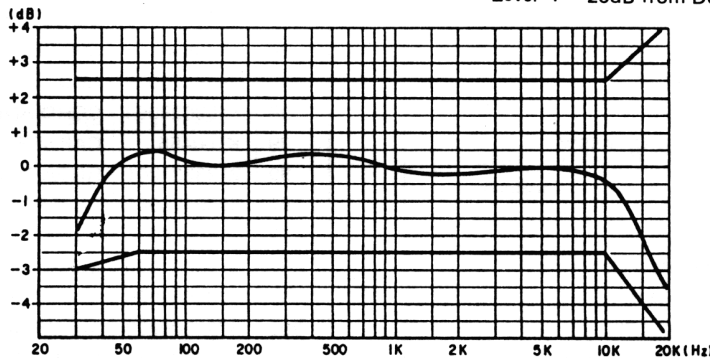

9. Adjusting the CTS

- (1) Adjusting the CTS Amplifier Gain
- Set the switch S701 of the CTS circuit board to the TEST side and press the CTS START button. During its operation, adjust VR 501 (L ch), VR 601 (R ch) so that the levels at TP(L), TP(R) alternates frequently between H → L or L → H.
- (2) Checking the CTS Operation
- 1) Load the LX-C60 cassette tape. Light the preset lamp and set to the preset mode. Record/playback 1kHz and 12kHz signals and note the frequency response.
 - 2) Press the CTS START button. After it is completed, (CTS lamp lit), record/playback the 1kHz signals and check to make sure the frequency response is improved over those recorded in section (1).

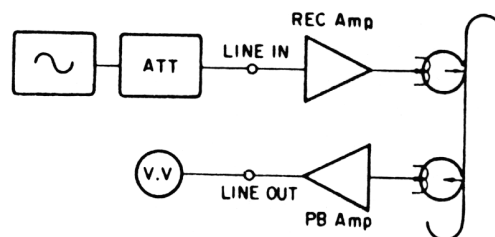

● Beat Interference

Beat interference may result if the unit is used close to an AM tuner. In this case separate the distance between the tuner and the cassette deck.

PARTS LIST OF MECHANISM UNIT

Ref. No.	Part No.	Part Name	Remarks
1	4118350402	MECHA BASE ASS'Y	
2	4438636107	C-GUIDE POST	
3	4318076201	HEAD SLIDER ASS'Y	
4	4318083304	HEAD PLATE ASS'Y	
5	4258011009	φ3 STEEL BALL	
6	4318080200	BALL GUIDE PLATE	
7	4638230002	SPRING	
8	4638819009	SPRING	
9	3918076000	R/P HEAD	
10	4438671104	SPECIAL NUT	
11	4418994005	CORD HOLDER	
13	4418967304	T-ARM BASE ASS'Y	
14	4338210102	E-HEAD BASE ASS'Y	
15	3918031003	E-HEAD	
16	4638626108	SPRING	
17	4338212304	TENSION ARM ASS'Y	
18	4638235201	SPRING	
19	4638630000	SPRING	
20	4338224208	STOPPER	
21	4438674305	TENSION POST	
22	4618125108	FRICTION FELT	
23	4338194105	P-ROLLER ARM ASS'Y	
24	4638231108	SPRING	
25	4218320109	REEL ASS'Y	
26	4638624100	SPRING	
27	4338199003	FRICTION PLATE	
28	4418961300	LAMP HOLDER	
29	4338238100	I. ARM (B) G ASS'Y	
30	4338239109	IDLER ARM (B) ASS'Y	
31	4218324202	IDLER ASS'Y	
32	4618126107	FRICTION FELT	
33	4638625109	SPRING	
34	4428029102	THRUST WASHER	
35	4338236102	IDLER ARM (A) ASS'Y	
36	4638244001	SPRING	
37	2178079000	DC MOTOR ASS'Y	
39	4418962105	DC MOTOR FIX PLATE	
40	4318081209	BRAKE	
41	4618127106	BRAKE SHOE	
42	4638234105	SPRING	
43	4338232106	BRAKE ARM ASS'Y	
44	4438648205	METAL HOUSING ASS'Y	
45	4218355006	CAPSTAN WHEEL SUB ASS'Y	
46	2228530004	FG PATTERN P.W.B	
47	4418964103	BACK PLATE	
48	4438650206	CAPSTAN STOPPER	
49	3468148200	STATOR COIL	
50	4770090074	WASHER	
51	2760303016	HL-300C	
52	4418966208	CAM MOTOR HOLDER	
54	2178080109	CAM MOTOR ASS'Y	
55	4248027304	CAM	
57	4428018104	ENCORDER BRACKET	

Ref. No.	Part No.	Part Name	Remarks
58	4338225304	HOLD SENSOR (1)	
59	4338226400	HOLD SENSOR (2)	
60	4338227302	LEVER	
61	4638240005	SPRING	
62	4418969302	RIGHT STAY ASS'Y	
63	4418971206	LEFT STAY ASS'Y	
64	4338216203	EJECT LEVER	
65	4338218201	HOOK LEVER (A)	
66	4338219006	HOOK LEVER (B) ASS'Y	
67	4638238004	SPRING	
68	1038212306	CASSETTE BOX (A)	
69	4338215301	CASSETTE BOX (B)	
70	1038213004	CASSETTE SUPPORT (L)	
71	1038219105	CASSETTE SUPPORT (R)	
72	4438654202	COLLAR	
73	4638236103	BOX SPRING	
74	4698013104	AIR DUMPPER	
75	2129200006	SLIDE SWITCH	
76	1448508105	ESC PLATE	
77	3939179009	LED	
78	4458028009	CORD HOLDER	
79	KU-0455	CAP SERVO UNIT	
80	2123331201	ROTARY ENCORDER	
81	3939178000	LN25RCP	
82	3939026000	PN150	
83	2129201005	SLIDE SWITCH	
301	4737002005	3x6 CBTS (S)	
302	4737500028	3x8 CFTS (P)	
307	4713202010	2.6x5 CBS	
310	4713206016	2.6x12 CBS	
311	4756020000	2N	
312	4713102013	2x5 CBS	
313	4713201011	2.6x4 CBS	
314	4770090003	WASHER	
315	4751119107	SLIT WASHER	
316	4713104011	2x8 CBS	
317	4751121108	SLIT WASHER	
318	4737500002	3x6 CBTS (P)	
319	4761000002	1.5E-RING	
320	4713802012	2.6x3 CBS	
321	4751120109	SLIT WASHER	
322	4713801039	2x3 CBS	
323	4761003009	3E-RING	
324	4761002000	2.5E-RING	
325	4713801026	2x14 CBS	
326	4713204018	2.6x8 CBS	
327	4730154028	2x8 CRTS	
328	4751003006	3W	

PARTS LIST OF EXPLODED VIEW

Ref. No.	Part No.	Part Name	Remarks
201	3388013004	V. MECHA. [61] UNIT	
202	1038214537	FRONT PANEL ASS'Y	DR-M2, EU, EC
	1038214511	FRONT PANEL ASS'Y	DR-M2, E2, E1 EA, EF, EG, EK
	1038214524	FRONT PANEL ASS'Y	DR-M3, EU, EC
	1038214508	FRONT PANEL ASS'Y	DR-M3, E2, E1 EA, EF, EG, EK
203	1138156304	PUSH KNOB (A)	
204	1138157400	PUSH KNOB (B)	
205	4638627000	SPRING	
206	1038217314	CASSETTE WINDOW	EU, EC
	1038217301	CASSETTE WINDOW	E2, E1, EA, EF, EG, EK
207	1038224200	CONTROL COVER ASS'Y	
209	1168004235	CONTROL SHEET	DR-M2, EU, EC
	1168004219	CONTROL SHEET	DR-M2, E2, E1, EA, EF, EG, EK
	1168004222	CONTROL SHEET	DR-M3, EU, EC
	1168004206	CONTROL SHEET	DR-M3, E2, E1, EA, EF, EG, EK
210	1138158205	PUSH KNOB (C)	
211	1138159327	PUSH KNOB (D)	EU, EC
	1138159301	PUSH KNOB (D)	E2, E1, EA, EF, EG, EK
212	1138159330	PUSH KNOB (D)	EU, EC
	1138159314	PUSH KNOB (D)	E2, E1, EA, EF, EG, EK
213	1198009404	GUIDE RAIL	
214	1198009417	GUIDE RAIL	
215	1138160219	SLIDE KNOB (A)	
216	1138155101	SLIDE KNOB (B)	DR-M3
	1138155101	SLIDE KNOB (B)	DR-M2, EU, EC
	1138155114	SLIDE KNOB (B)	DR-M2, E2, E1, EA, EF, EG, EK
217	1028319206	TOP COVER	
218	4118341505	CHASSIS	EU, EC, E2
	4118341518	CHASSIS	E1
	4118341505	CHASSIS	EA, EF, EG, EK
219	4610162004	FELT PAD	
220	4118342300	TRANS BRACKET	EU, EC, E1
	4118342313	TRANS BRACKET	E2, EA, EF, EG, EK
221	4118343202	POWER SW BRACKET	
222	1038225102	P.S. LEVER GUIDE	
223	4118344308	CONT. & METER FRAME	
224	4118345307	SHIELD PLATE	
225	1298019307	COLOR FILTER	
226	1298022006	MASK SHEET	
227	1198010202	DUMMY BLOCK (A)	PLAY, STOP
228	1198011308	DUMMY BLOCK (B)	REC. PAUSE FF. REW
229	1198012200	DUMMY BLOCK (C)	RESET

Ref. No.	Part No.	Part Name	Remarks	
230	1198013209	DUMMY BLOCK (D)	DR-M3 FTS START	
231	1198014208	DUMMY BLOCK (E)	DR-M3 MEMORY/PRESET	
232	4128747005	SHIELD BRACKET		
233	4118346102	ANGLE		
234	4318082402	POWER SW LEVER		
235	4118347101	EARTH PLATE (A)		
⚠	236	2339064003	POWER TRANS	EU, EC
		2339068009	POWER TRANS	E2, EF, EG
		2339071009	POWER TRANS	E1
		2339072008	POWER TRANS	EA, EK
⚠	237	2062019008	AC CORD WITH PLUG	EU, EC
		2062002031	AC CORD WITH PLUG	E2, EF, EG
		2006031026	AC CORD WITH PLUG	E1
		2006019310	AS 3P AC CORD	EA
		2062024006	AC CORD WITH LABEL	EK
⚠	238	MD-3802	BUSHING	EU, EC, E1
		4450018004	BUSHING	E2, EF, EG, EK
		MD-2982	CORD BUSH	EA
239	1058089108	BOTTOM COVER		
240	KU-0449	PWR & LOGIC UNIT	DR-M3	
	KU-0449-1	PWR & LOGIC UNIT	DR-M2	
241	KU-0449 A	PWR & LOGIC ASS'Y	DR-M3	
	KU-0449A1	PWR & LOGIC ASS'Y	DR-M2	
242	2048110002	8P DIN JACK		
243	KU-0449 B	TIMER SWITCH ASS'Y		
⚠	244	KU-0449 C	POWER SUPPLY ASS'Y	
⚠	245	2129136028	POWER SWITCH	EU, EC
		2129136015	POWER SWITCH	E2, E1, EA, EF, EG, EK
246	KU-0450	AUDIO UNIT	DR-M3	
	KU-0450-1	AUDIO UNIT	DR-M2	
247	KU-0450A	AUDIO ASS'Y	DR-M3	
	KU-0450A1	AUDIO ASS'Y	DR-M2	
248	2118071107	J3020V20DA103		
249	2048108001	MIC-JACK		
250	2048109000	HEADPHONE JACK		
251	2048114008	4P PIN JACK		
252	2129189004	PUSH SWITCH		
253	KU-0450B	INPUT VR ASS'Y		
254	2118072106	J10002H10CA503	INPUT VR	
255	KU-0451	FTS UNIT	DR-M3 only	
256	KU-0452	FL METER UNIT	DR-M3	
	KU-0452-1	FL METER UNIT	DR-M2	
257	KU-0453	FL COUNTER UNIT		
258	KU-0454	CONTROL UNIT	DR-M3	
	KU-0454-1	CONTROL UNIT	DR-M2	
259	2129213103	PUSH SWITCH		
260	2129214102	PUSH SWITCH		
261	2124388004	TACT SWITCH		
262	3939180001	LED (RED)		
263	3939181000	LED (AMBER)		
264	3939182009	LED (GREEN)		
265	4428017008	COVER PLATE	DR-M2 only	
266	4428055002	P.W.B SUPPORT		

KU-0455A CAPSTAN SERVO UNIT

Ref. No.	Part No.	Part Name	Remarks
267	1298022019	MASK SHEET	
268	2123315023	VOLTAGE SELECTOR	E1 only
301	4737002005	3x6 CBTS (S)	
302	4737500028	3x8 CFTS (P)	
303	4737003004	3x8 CFTS (S)	
304	4737500015	3x8 CBTS (P)	
306	4737503009	4x8 CTTS (P)	
307	4713203019	2.6x5 CBS	
308	4713303016	3x6 CBS	
309	4730359014	3x16 CRTS	
310	4737002018	3x8 CBTS (S)	

ACCESSORIES GROUP

Ref. No.	Part No.	Part Name	Remarks
	2032101001	2P CONNECTOR CORD	
	5118233007	INS. MANUAL	EU, EC
	5118241002	INS. MANUAL	E2, E1, EA, EF, EG, EK
	5118153006	SAFETY INSTRUCTION	
	5158053001	WARRANTY IN ENVELOPE	

CARTON CASE GROUP

Ref. No.	Part No.	Part Name	Remarks
	5018891000	CARTON CASE	DR-M3
	5018291013	CARTON CASE	DR-M2
	5038042006	PACKING	
	5058092007	RAMINATE COVER	

Ref. No.	Part No.	Part Name	Remarks
IC901	2630224005	μPC1043C	
IC902	2630189001	M5218L	
TR904,906	2720055029	2SB772Q/P	
TR901,902	2730204035	2SC2320E/F	
TR903,905	2740078031	2SD882Q/P	
HE901,902	2760303016	HL-300C	
			Metal film
R908	2452231001	RN14K2E104G	100KΩ
VR901	2116020011	K08Q06MB503	50KΩB
			Variable resistor
C906	2533643000	CC45SL1H471J	470PF 50V
C910	2539013003	CK45=1E473M	0.047μF 25V
C901,902	2539014002	CK45=1E683M	0.068μF 25V
C912	2531055056	CK45B1H221K	220PF 50V
			Electrolitic
C905	2544129005	CE04W1A470=	47μF 10V
C903,913	2544132005	CE04W1C100=	10μF 16V
C904	2544140000	CE04W1V4R7=	4.7μF 35V
C911	2544146004	CE04W1H010=	1μF 50V
			Film
C907	2551069006	CQ93M1H562K	0.0056μF 50V
C914,915	2551076002	CQ93M1H223K	0.022μF 50V
C908	2554194046	CQ93P1H223J	0.022μF 50V
CN901	2032075001	2P CONNECTOR BASE	
CN902	2031639008	4P EI CON WITH WIRE	
CN904	2041630000	5P EI CON WITH WIRE	KU-0455B
CN905	2041632008	6P MINI CONNE CORD	KU-0455C
LE4,6	3939178000	LN25RCP	"
PTR1,2	3939026000	PN150	"
CN906	2031638038	2P EI CON WITH WIRE	KU-0455D
CN907	2031639024	4P EI CON WITH WIRE	"

• The carbon resistors rated at ¼W are not listed herein.

Remarks symbols in the parts list refer to the following countries and areas.

EA: Australia
 EK: United Kingdom
 EU: U.S.A.
 E1: Multiple voltage model
 E2: European continent
 EF: French
 EG: German
 EC: Canada

WARNING:

Parts marked with  and/or shading have special characteristics important to safety. Be sure to use the specified parts for replacement.

KU-0449A POWER AND LOGIC UNIT

Ref. No.	Part No.	Part Name	Remarks
IC1	2620408006	UPC 1511C	
IC2	2620229007	M74LS138P	
IC3, 4	2620197003	M74LS32P	
IC5, 6	2620326007	BA6109	
IC7	2630225004	NJM78M09A	
TR1~3	2710102034	2SA1015Y/GR	
21, 22			
TR19	2710105002	2SA966Y	
TR23	2720055029	2SB772Q/P	
TR4~8, 10	2730245023	2SC2603E/F	
14~16			
24~27			
TR17,18,20	2740078031	2SD882Q/P	
DB1, 2	2760246005	RB152	
D18~21	2760237001	RV06	
24~28			
ZD1, 9	2760185027	HZ4B2	
ZD3	2760236057	HZ5C3	
ZD7	2760173042	HZ6B1	
ZD6, 4	2760173071	HZ6C3	
ZD5	2760218046	HZ9B1	
ZD8	2760052079	HZ11B2	
ZD10	2760299052	HZ3B3	
D1~12	2760049008	IS2076	
24~17			
22, 23			
R42	2442028017	RS14B2E330JFRF	Carbon film 33Ω ¼W
R30	2440029021	RS14B3A101JNBF	100Ω 1W
R29	2440079026	RS14B3D270JNBF	27Ω 2W resistor Block
RB-1	2462011046	RK99=2B472MP3	3.7KΩ ¼Wx3
RB-4	2462011075	RK99=2B103MP3	10KΩ ¼Wx3
RB-6	2462010076	RK99=2B103MP4	10KΩ ¼Wx4
RB-2	2462012003	RK99=2B103MP8	10KΩ ¼Wx8
RB-3	2462011088	RK99=2B153MP3	15KΩ ¼Wx3
RB-5	2462010092	RK99=2B104MP4	100KΩ ¼Wx4
C9, 11	2539013003	CK45=1E473M	Ceramic 0.047μF 25V
C6	2539014002	CK45=1E683M	0.068μF 25V
C1, 2, 8	2531024003	CK45F1H103Z	0.01μF 50V
10,12,25			
C4	2533627000	CC45SL1H101J	100PF 50V
C5	2533635005	CC45SL1H221J	220PF 50V
CB-2	2531153000	CK99B1H102MP4	0.001μF 50V
CB-1	2610036006	CK93F1H03ZF6	0.01μF 50V Electrolytic
C13, 16	2544009002	CE04W1A470=	47μF 10V
C15, 24		CE04W1A101=	100μF 10V
26,27,31,33			
C7	2544132005	CE04W1C100=	10μF 16V
C28	2544018006	CE04W1C101=	100μF 16V
C20, 21	2544163003	CE04W1C221=	220μF 16V
C23,29,30	2544163032	CE04W1C102=	1000μF 16V
C22	2544088007	CE04W1C222=	2200μF 16V

Ref. No.	Part No.	Part Name	Remarks
C14	2546071009	CE04W1E103=	10000μF 25V
C3, 24	2544140000	CE04W1V4R7=	4.7μF 35V
C17, 18	2544141009	CE04W1V100=	10μF 35V
C19	2544159004	CE04W1V101=	100μF 35V
CN3, 10	2035622066	5P MINI CONNE PIN	
CN2,6,9	2035622024	4P MINI CONNE PIN	
CN5	2035622095	9P MINI CONNE PIN	
CN1	2035622037	8P MINI CONNE PIN	
CN11	2035622082	6P MINI CONNE PIN	
CN4	2037642015	4P EI CON WITH WIRE	
CN7	2045405008	9P EI CON WITH WIRE	
CN12, 13	2032075001	2P CONNECTOR BASE	
CN8	2050170001	12P BOARD PIN BASE	DR-M3 only
	4178062109	HEAT SINK (L)	TR17
	4178079008	RADIATOR	TR18, 23, IC7
	2048110002	8P DIN JACK	
CRM1	3998031007	CERAMIC RESONATOR	800KHZ

• The carbon resistors rated at ¼W are not listed herein.

KU-0499B TIMER SWITCH UNIT

Ref. No.	Part No.	Part Name	Remarks
CN14	2129188005	SLIDE SWITCH	
	2039632023	5P MINI CONNE CORD	

KU-0449C POWER SUPPLY UNIT

Ref. No.	Part No.	Part Name	Remarks
⚠ SK1	2618006009	SPARK KILLER	EU, EC
⚠	2538010007	CK45=2GAC103P	E2, E1, EA, EA, EG, EK
⚠ LF1	2398019002	LINE FILTER COIL	
⚠	2061031045	FUSE 210mA	E1
⚠	2061031032	FUSE 160mA	E2, EA, EF, EG, EK
	5138254024	FUSE LABEL	E1
	5138254011	FUSE LABEL	E2, EA, EF, EG, EK

KU-0450A AUDIO AMP UNIT

Ref. No.	Part No.	Part Name	Remarks
IC304,305	2620277004	M74LS05P	
IC301	2630226003	M5220L	
IC102,202	2630222007	NE652	
106,206			
IC101,201	2630229000	LA6458DS	
103,203,			
104,204,			
105,205,			
303			
IC302	2630125007	MPC4557C	
TR303	2710102034	2SA1015Y/GR	
TR101~106	2730245023	2SC2603E/F	
108~113			
201~206			
208~213			
301, 302			
305~308			
TR107,207	2730198028	2SC1815 (GR)	
TR304	2730195005	2SC2060 (Q)	
TH-101,201	2760118007	D-33A	
ZD301	2760218046	HZ9B1	
	2760049008	1S2076	
			Variable resistor
Vr101,201	2116000031	V08PB102	1KΩB
Vr102,202	2116000044	V08PB503	" 50KΩB
Vr103,203	2116000086	V08PB204	" 200KΩB
VR301	2118071107	J3020V20DA103	" 10KΩA
			Ceramic
C102,202	2533627000	CC45SL1H101J	100PF 50V
C112,212	2533633007	CC45SL1H181J	180PF 50V
C319, 320	2539012004	CK45=1E333M	0.033μF 25V
C115,215	2539014002	CK45=1E683M	0.068μF 25V
139, 239			
C322	2531022005	CK45F1H222Z	0.0022μF 50V
C101,201	2531055056	CK45B1H221K	220PF 50V
160,260			
C132,232	2531004007	CK45B1H102K	0.001μF 50V
321			
C159,259	2531056026	CK45B1H122K	0.0012μF 50V
C155,255	2531005006	CK45B1H152K	0.0015μF 50V
C157,257	2531006005	CK45B1H222K	0.0022μF 50V
150, 250			
C156,256	2531061008	CK45B1H272K	0.0027μF 50V
C154,254	2531007004	CK45B1H332K	0.0033μF 50V
C316	2531062007	CK45B1H392K	0.0039μF 50V
			Electrolitic
C311	2544161047	CE04W0J471=	470μF 6.3V
C103,203	2544129005	CE04W1A470=	47μF 10V
301,302			
304,310			
C307,308	2544131006	CE04W1A221=	220μF 10V

Ref. No.	Part No.	Part Name	Remarks
C105,107	2544132005	CE04W1C100=	10μF 16V
108,111			
113,119			
125,126			
134,137			
145,146			
151,161			
205,207			
208,211			
213,219			
225,226			
234,237			
245,246			
251,261			
303,305			
306,312			
C131,133	2544140000	CE04W1V4R7=	4.7μF 35V
231,233			
313,314			
C117,124	2549014005	CE04W1HR10=	0.1μF 50V
142,149			
217,224			
242,249			
C118,143	2549014034	CE04W1HR15=	0.15μF 50V
218,243			
C309	2544147003	CE04W1H2R2=	2.2μF 50V Film
C158,258	2551063002	CQ93M1H182K	0.0018μF 50V
C109,120	2551120084	CQ93M1H472J	0.0047μF 50V
135,144			
153,209			
220,235			
244,253			
C104,204	2551120097	CQ93M1H562J	0.0056μF 50V
C106,121	2551121025	CQ93M1H103J	0.01μF 50V
138,206			
221,238			
C315	2551074004	CQ93M1H153K	0.015μF 50V
C110,136	2551121083	CQ93M1H333J	0.033μF 50V
210,236			
C116,123	2551078000	CQ93M1H333K	0.033μF 50V
141,148			
216,223			
241,248			
318			
C114,140	2551122008	CQ93M1H473J	0.047μF 50V
214,240			
C152,252	2551080001	CQ93M1H473K	0.047μF 50V
C317	2554118909	CQ93P2A562J	0.056μF 100V
C122,147	2561030025	CF93B2A224J	0.22μF 100V
222,247			
S301	2129189004	PUSH SWITCH	
RL301	2140020003	REED RELAY	
L102,104	2358011008	INDUCTOR	
202,204			
L105,205	2358005001	INDUCTOR	
L301	2358005014	INDUCTOR	

KU-0451 CTS UNIT

Ref. No.	Part No.	Part Name	Remarks
L101,201	2310825008	BIAS FILTER	
L103,203	2328043006	MPX FILTER	
L106,206	2328044005	BAND TRAP FILTER	
T301	2398016005	OSC COIL	
J303	2048108001	MIC JACK	
J301	2048109000	HEAD PHONE JACK	
J302	2048114008	4P PIN JACK	
CN101,201	2032075001	2P CONNECTOR BASE	
CN302	2035622008	3P MINI CONNE PIN	
CN301,303	2035622024	4P MINI CONNE PIN	
CN307	2050170001	12P BOARD PIN BASE	DR-M3 only
CN306	2031638012	2P EI CON WITH WIRE	
CN305	2047788008	12P EI CON ASS'Y	
CN304	2045404009	9P EI CON WITH WIRE	

• The carbon resistors rated at ¼W are not listed herein.

KU-0450B INPUT VOLUME UNIT

Ref. No.	Part No.	Part Name	Remarks
VR302	2118072106	J10001H10CA503	50KΩA

Ref. No.	Part No.	Part Name	Remarks
IC701	2620346003	HD44750A42	
IC703	2630161003	UPC358C	
IC501,601	2630229000	LA6458DS	
702,704			
TR501~511	2730245023	2SC2603E/F	
601~611			
702~712			
D503,504	2760001004	1N34A	
603,604			
D501,502	2760049008	1S2076	
601,602,701			
Vr501,601	2116004024	V08QB202	Variable resistor 2KΩB
C504,604	2531002009	CK45B1H471K	Ceramic 470PF 50V
CB701,702	2531151002	CK99B1H102MP4	0.001μF 50V
C704	2544130007	CE04W1A101=	Electrolitic 100μF 10V
C507,508	2544132005	CE04W1C100=	10μF 16V
512,607			
608,612			
C701,703	2544134003	CE04W1C330=	33μF 16V
C506,509	2544140000	CE04W1V4R7=	4.7μF 35V
513,606			
609,613			
C503,603	2551060005	CQ93M1H102K	Film 0.001μF 50V
C505,605	2551061004	CQ93M1H122K	0.0012μF 50V
C610,611	2551062003	CQ93M1H152K	0.0015μF 50V
C502,602	2551063002	CQ93M1H182K	0.0018μF 50V
C501,601	2551066009	CQ93M1H332K	0.0033μF 50V
C510,511	2551074004	CQ93M1H153K	0.015μF 50V
C702	2551079009	CQ93M1H393K	0.039μF 50V
S701	2129190103	SLIDE SWITCH	
L501,601	2310825009	BIAS FILTER	
CN701	2035622037	8P MINI CONNE PIN	
C702,703	2050171000	12 PIN BOARD CONTACT	

• The carbon resistors rated at ¼W are not listed herein.

KU-0452 FL METER UNIT

Ref. No.	Part No.	Part Name	Remarks
FL801	3939176002	FL METER	
	4418997002	METER HOLDER	
IC801	9ZLBL141	LBL-141	
TR801~804	9Z2SA733	2SA733	
TR805	2730130002	2SC945P	
D802	2760038006	1S1588	
D801	9ZRD5.1EB	RD5.1EB	
Vr801,802	2116000044	V08PB503	Variable resistor 50KΩB
C801,802 805	2539015001	CK45B=1E104M	Ceramic 0.1μF 25V
C807	2544138009	CE04W1E470M	Electrolitic 47μF 10V
C803,804	2544140000	CE04W1V4R7M	4.7μF 35V
C806	2549014021	CE04W1HR33M	0.33μF 50V
C809	2544145005	CE04W1HR47M	0.47μF 50V
C808	2544089006	CE04W1H010M	1μF 50V
CN801	2035622024	4P MINI CONNE PIN	
CN802	2035622053	12P MINI CONNE PIN	

• The carbon resistors rated at ¼W are not listed herein.

KU-0452-1 FL METER UNIT

Ref. No.	Part No.	Part Name	Remarks
FL801	3939176002	FL METER	
	4418997002	METER HOLDER	
IC801	9ZLBL142	LBL-142	
TR801~803	9Z2SA733	2SA733	
Vr801,802	2116000044	V08PB503	Variable resistor 50KΩB
C801,802 805	2539015001	CK45B=1E104M	Ceramic 0.1μF 25V
C803,804	2544132005	CE04W1C100M	Electrolitic 10μF 16V
C806	2549014021	CE04W1HR33M	0.33μF 50V
CN801	2035622024	4P MINI CONNE PIN	
CN802	2035622053	12P MINI CONNE PIN	

• The carbon resistors rated at ¼W are not listed herein.

KU-0453 FL COUNTER UNIT

Ref. No.	Part No.	Part Name	Remarks
FL401	9ZFG46C5	FL COUNTER	
	4418993006	COUNTER HOLDER	
IC401	9ZHD38750A	HD38750A38	
IC402	9ZHD14069U	HD14069UBP	
IC403	9ZHD7406	HD7406	
TR401,402	2730198002	2SC1815Y	
D401~403	9Z1SS53	1SS53	
XT401	9ZCSB400P	CERAMIC RESONATOR	
C402	2533629008	CC45SL1H121J	Ceramic 120PF 50V
C403	2536430003	CC45SL1H471J	470PF 50V
C404	2544134003	CE04W1C330=	Electrolitic 33μF 16V
C401	2544164002	CE04W1E4R7=	4.7μF 25V
CN402	2032075001	2P CONNECTOR BASE	
CN403	2035622082	6P MINI CONNE PIN	
CO401	2035622095	9P MINI CONNE PIN	

• The carbon resistors rated at ¼W are not listed herein.

KU-0454/0454-1 CONTROL UNIT

Ref. No.	Part No.	Part Name	Remarks
R451	2412072006	RD14B2E151J	KU-0454
R452	2412076002	RD14B2E221J	KU-0454
S451	2129213103	PUSH SWITCH	3 KEY
S452	2129214102	PUSH SWITCH	2 KEY
S453~461	2124388004	TACT SWITCH	KU-0454
S453~458	2124388004	TACT SWITCH	KU-0454-1
461			
LD451	3939180001	LED (RED)	
LD452,456	3939181000	LED (AMBER)	KU-0454
LD452	3939181000	LED (")	KU-0454-1
LD453~455	3939182009	LED (GREEN)	KU-0454
LD453	3939182009	LED (")	KU-0454-1
CN452	2041631009	6P EI CON ASS'Y	
CN453	2045400003	8P EI CON ASS'Y	KU-0454
CN451	2045401002	12P EI CON ASS'Y	
	4438693205	LED GUIDE (A)	
	4438694204	LED GUIDE (B)	KU-0454

EXPLODED VIEW OF MECHANISM UNIT

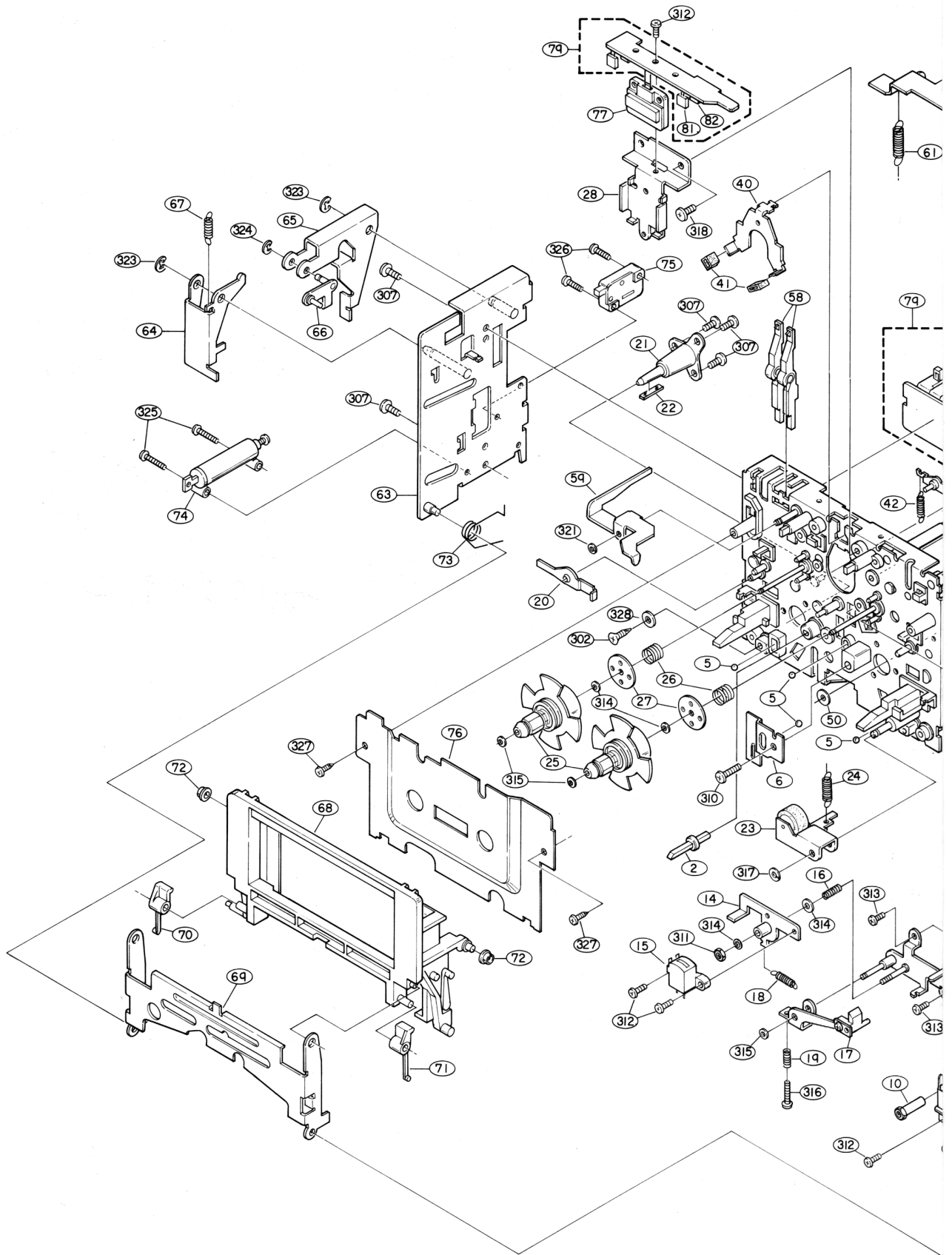

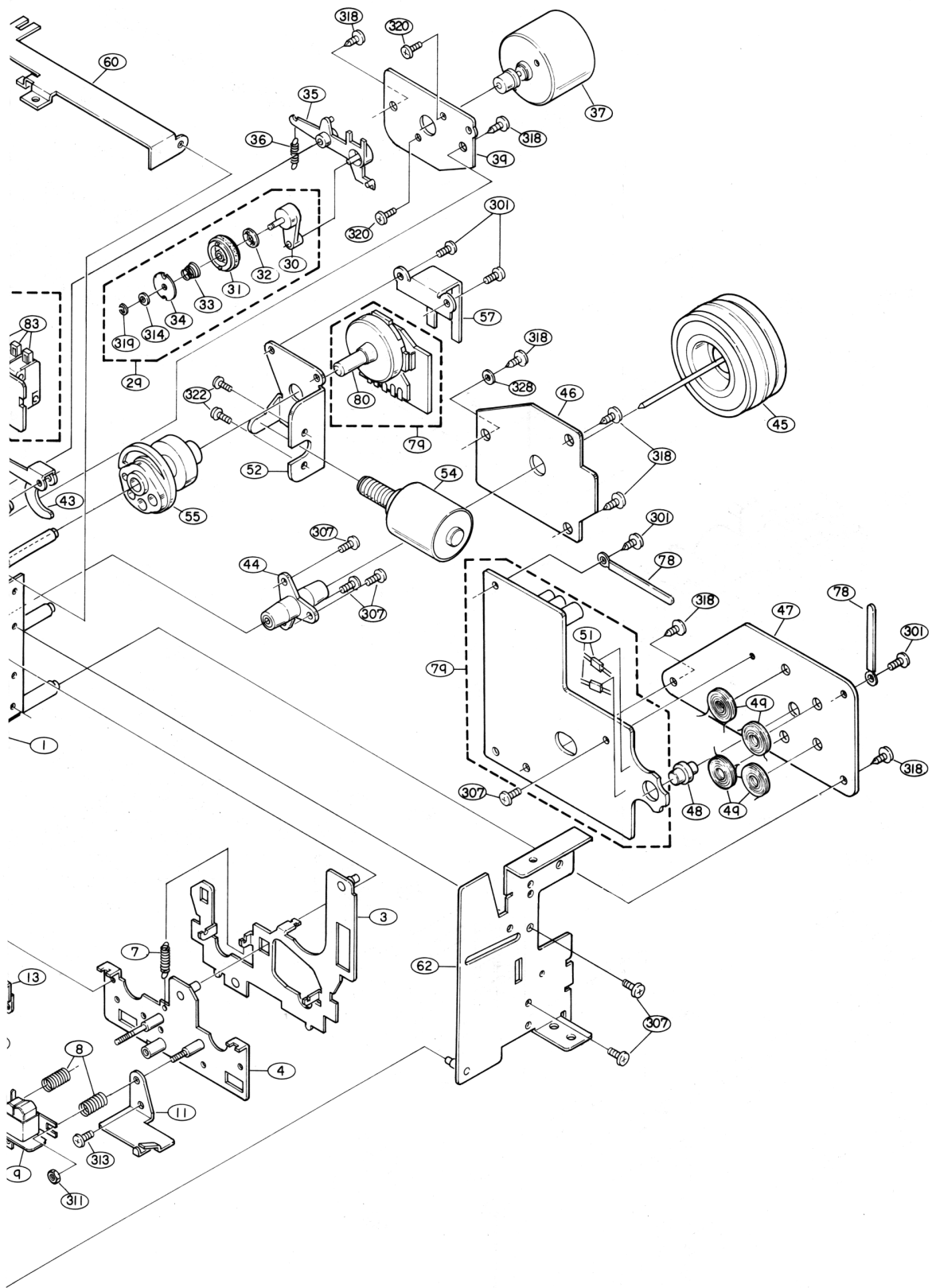

EXPLODED VIEW OF CABINET AND CHASSIS GROUP

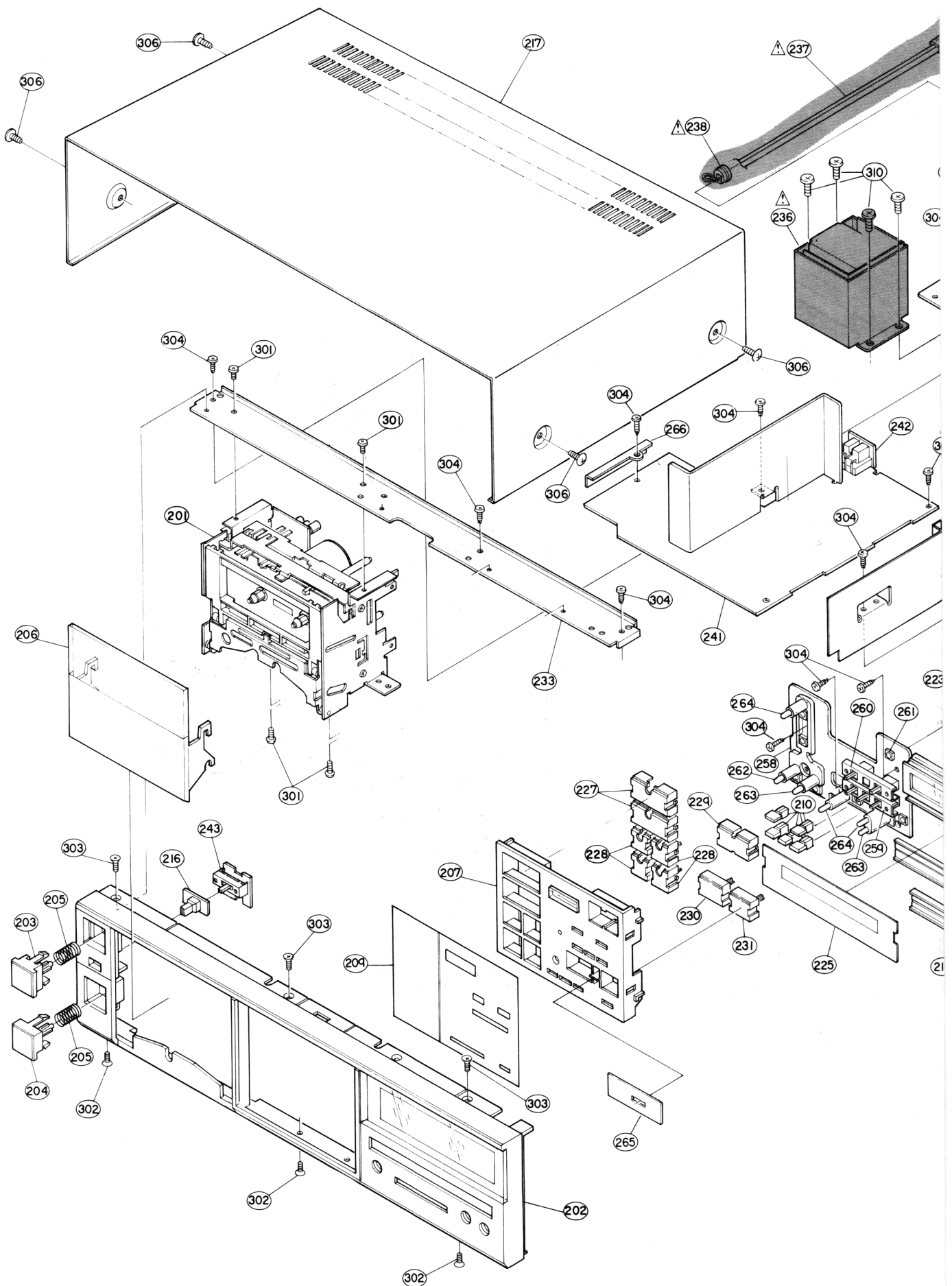

P. W. BOARD OF KU-0450 AUDIO AMP UNIT

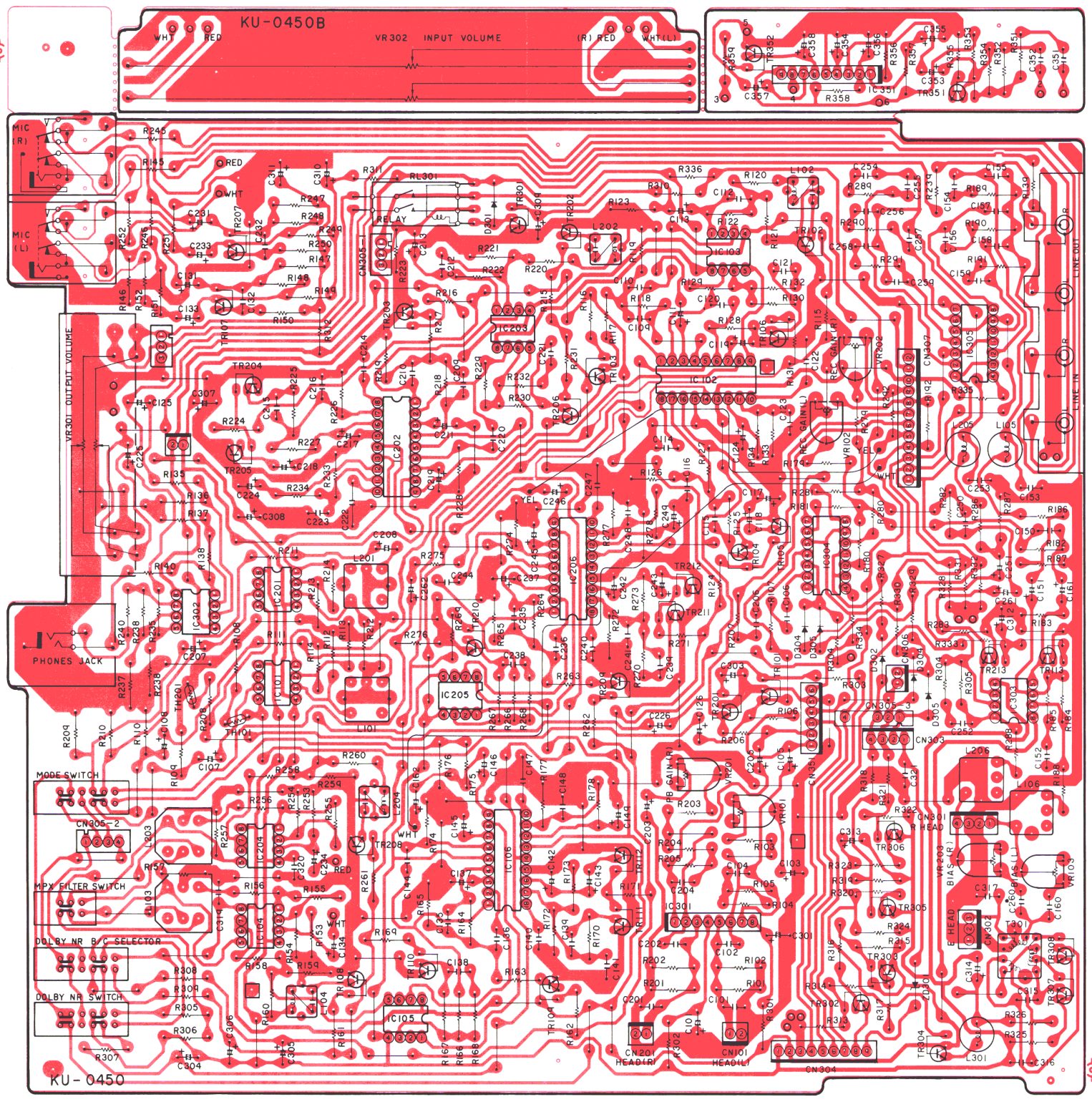

P. W. BOARD OF KU-0451 CTS UNIT

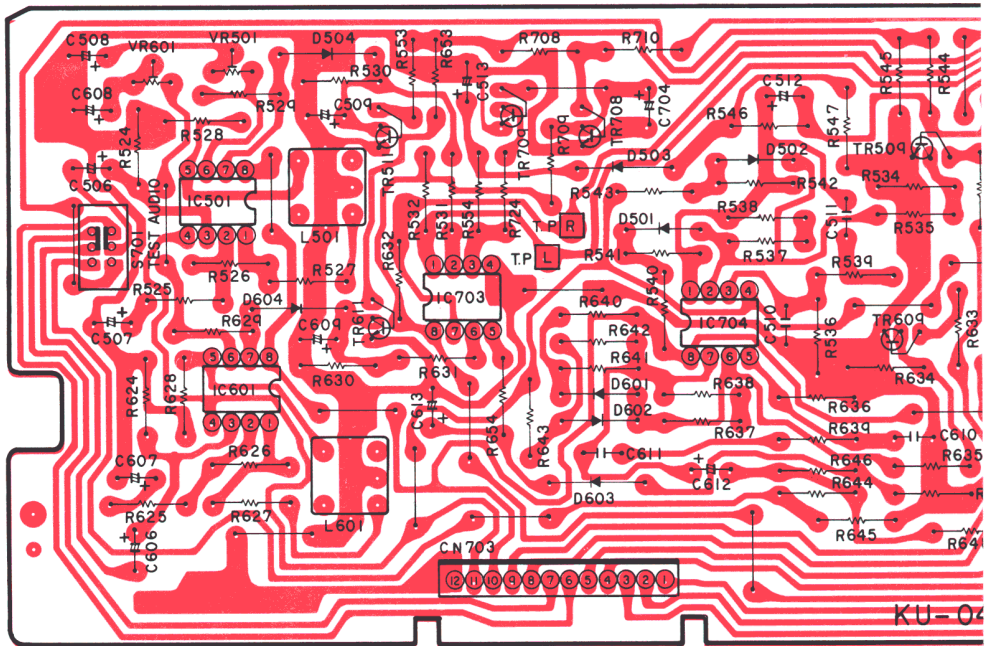

P. W. BOARD OF KU-0452 FL METER UNIT

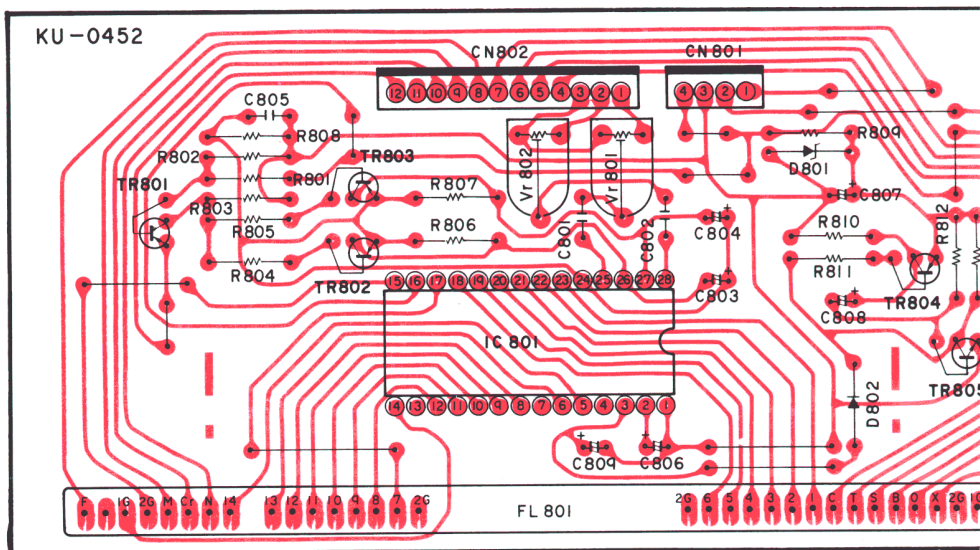

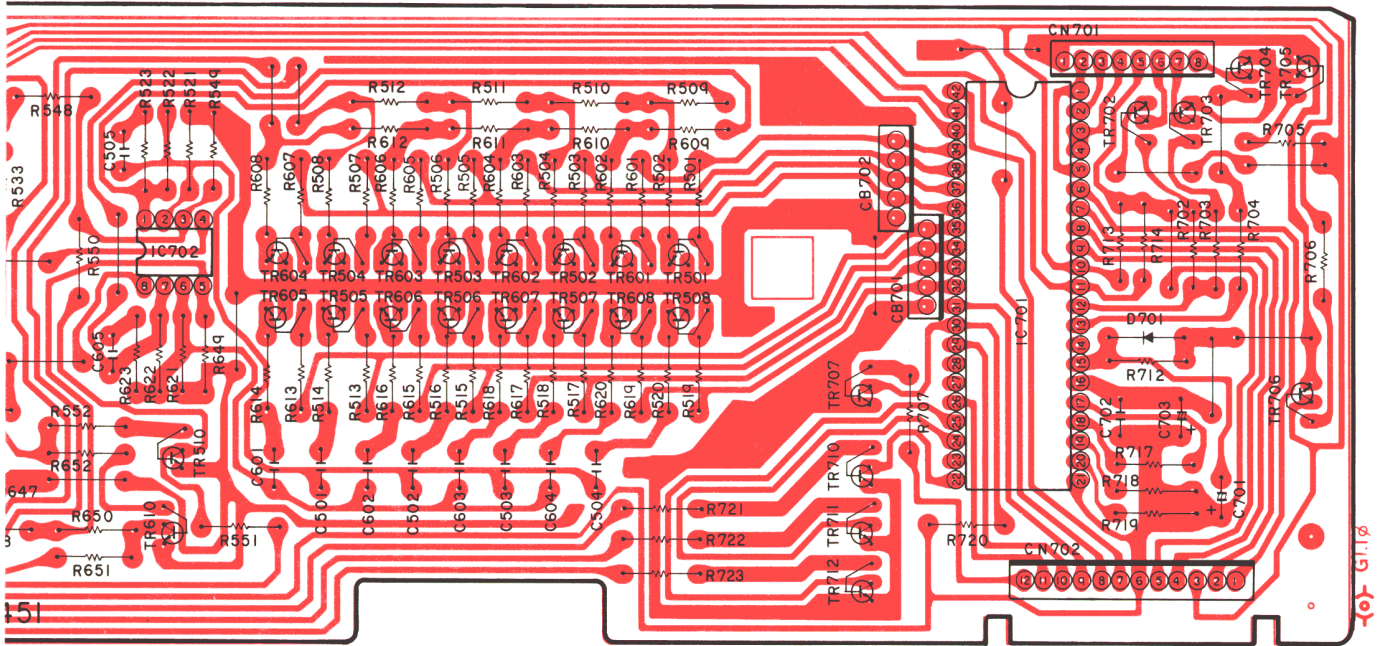

P. W. BOARD OF KU-0452-1 FL METER UNIT

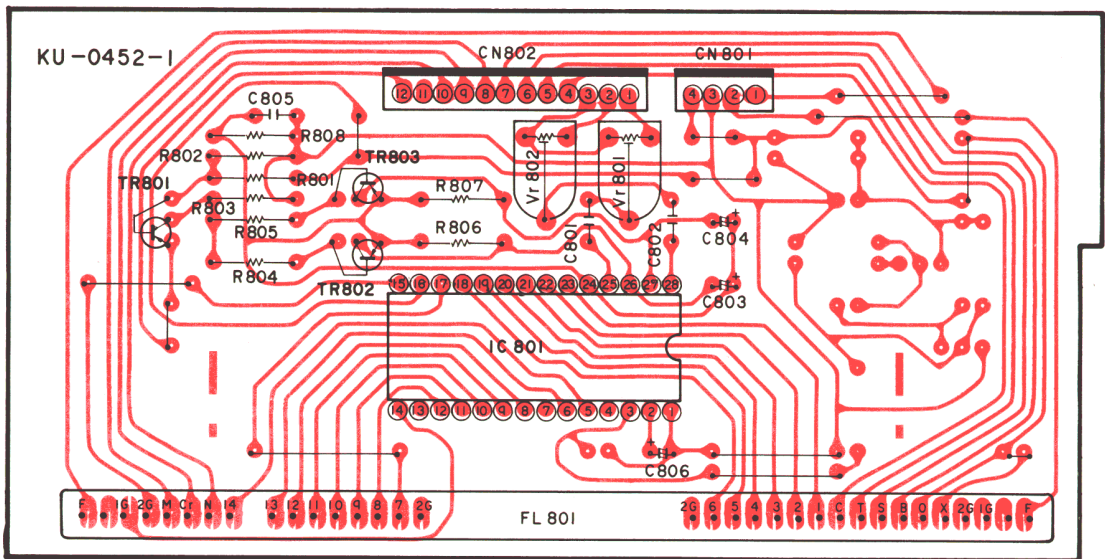
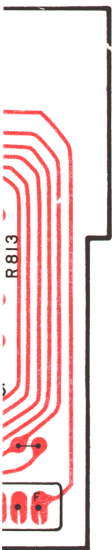

P. W. BOARD OF KU-0449 LOGIC AND POWER UNIT

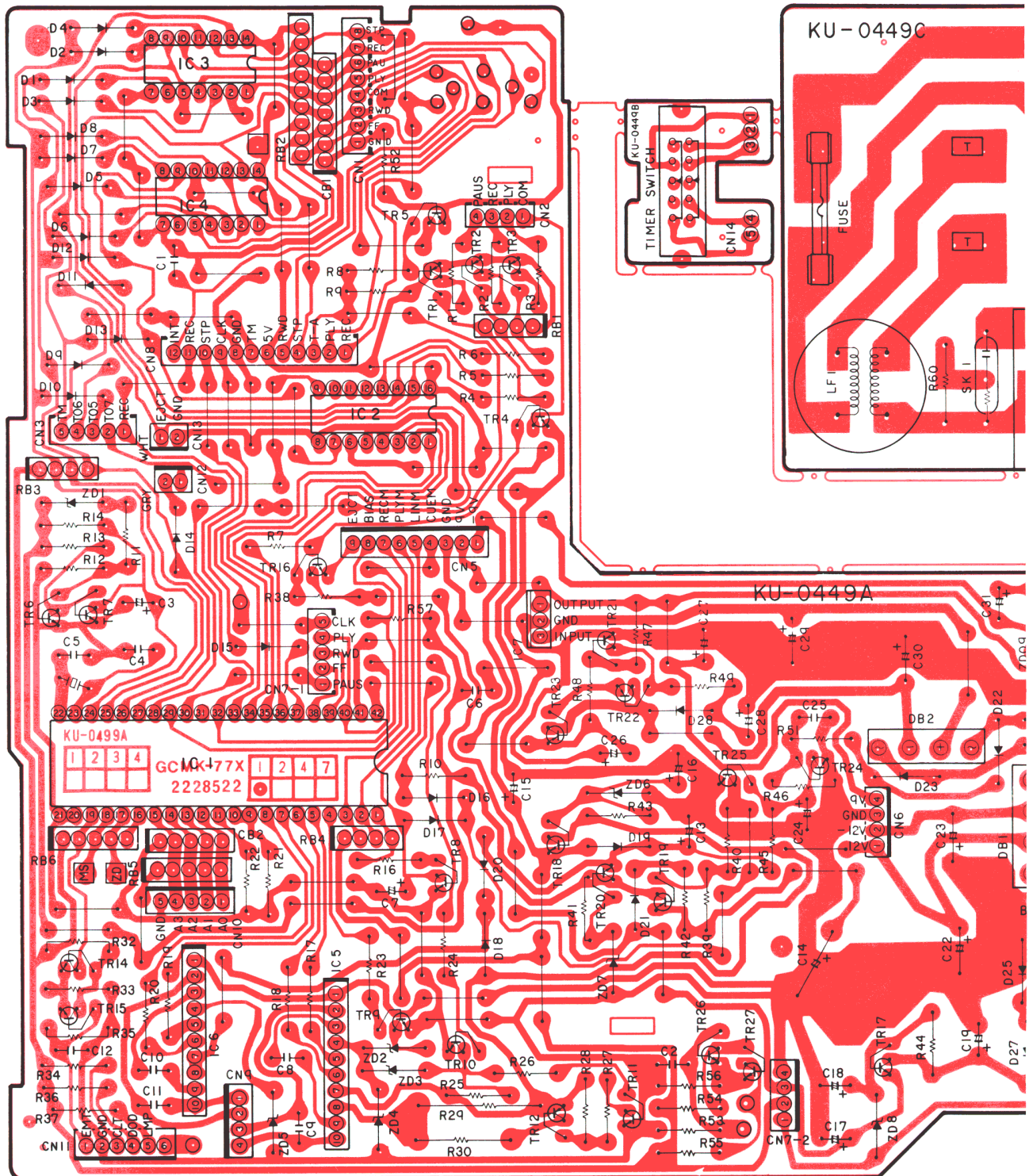

(0)

P. W. BOARD OF KU-0453 FL COUNTER UNIT

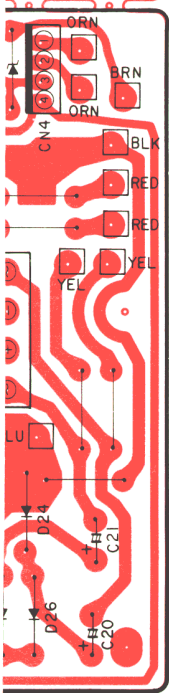
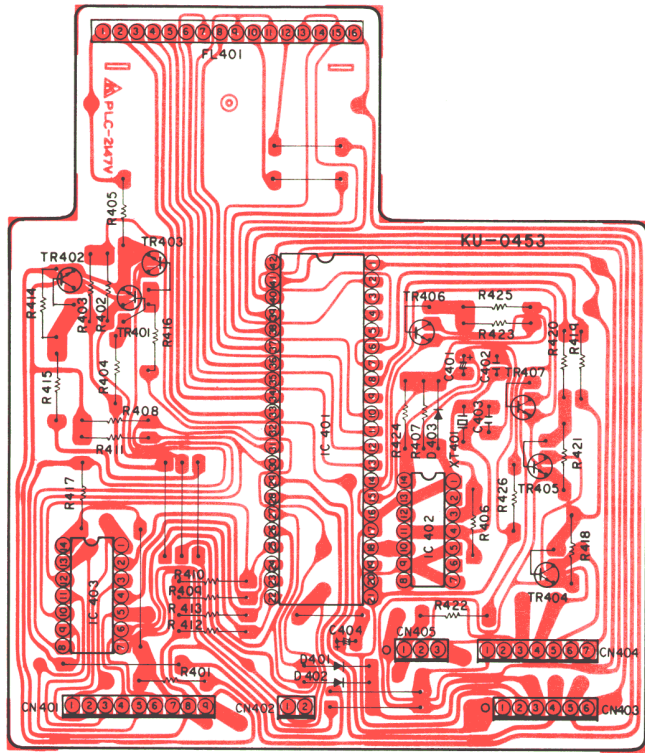
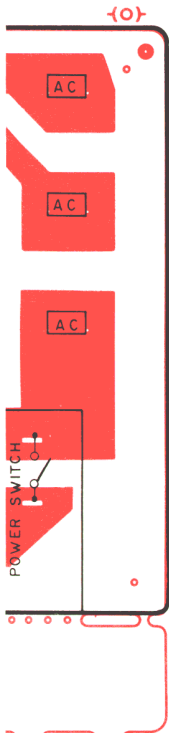

P. W. BOARD OF KU-0454 CONTROL UNIT

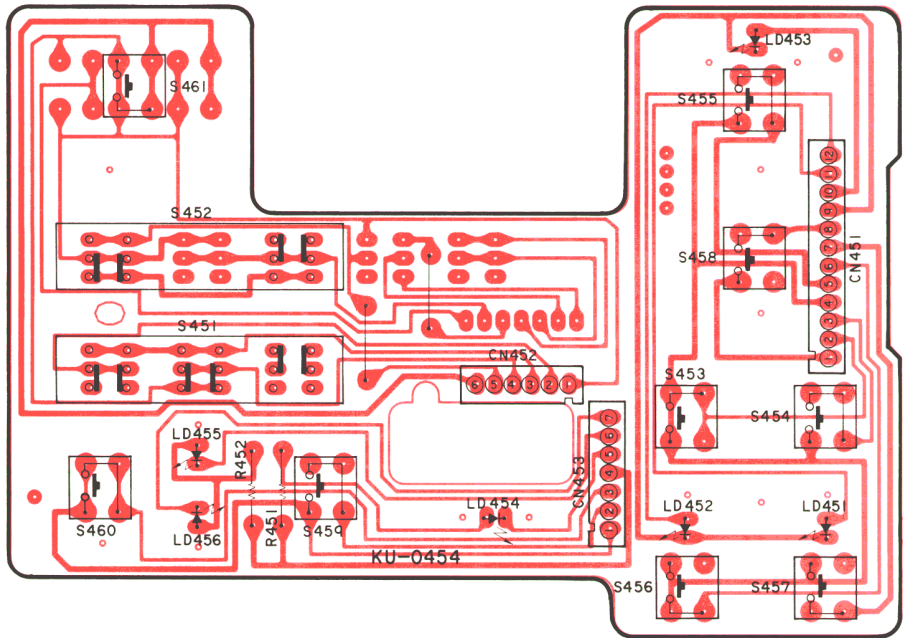

←G11φ

P. W. BOARD OF KU-0455 CAPSTAN SERVO UNIT

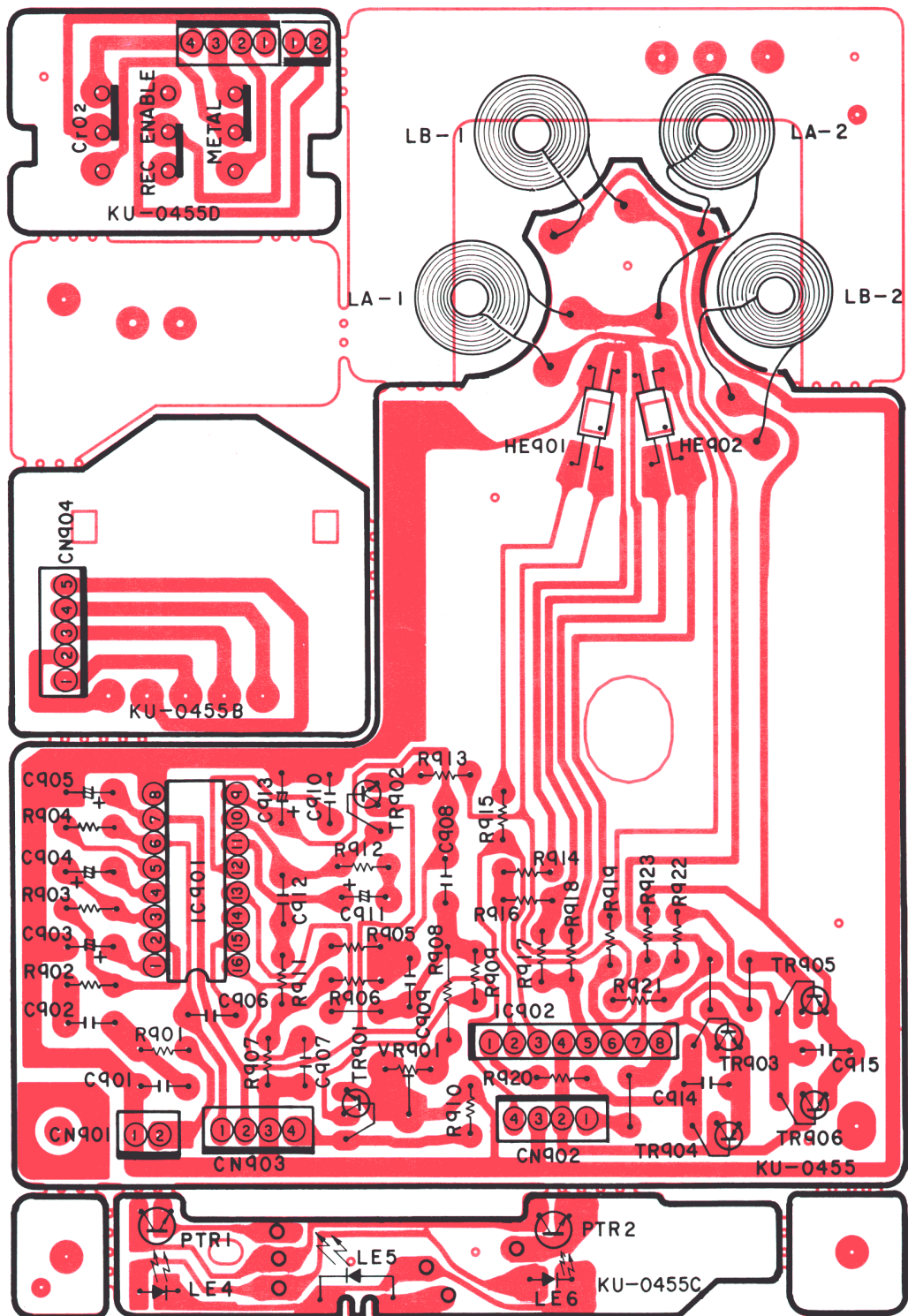

CONNECTIONS OF P. W. BOARD

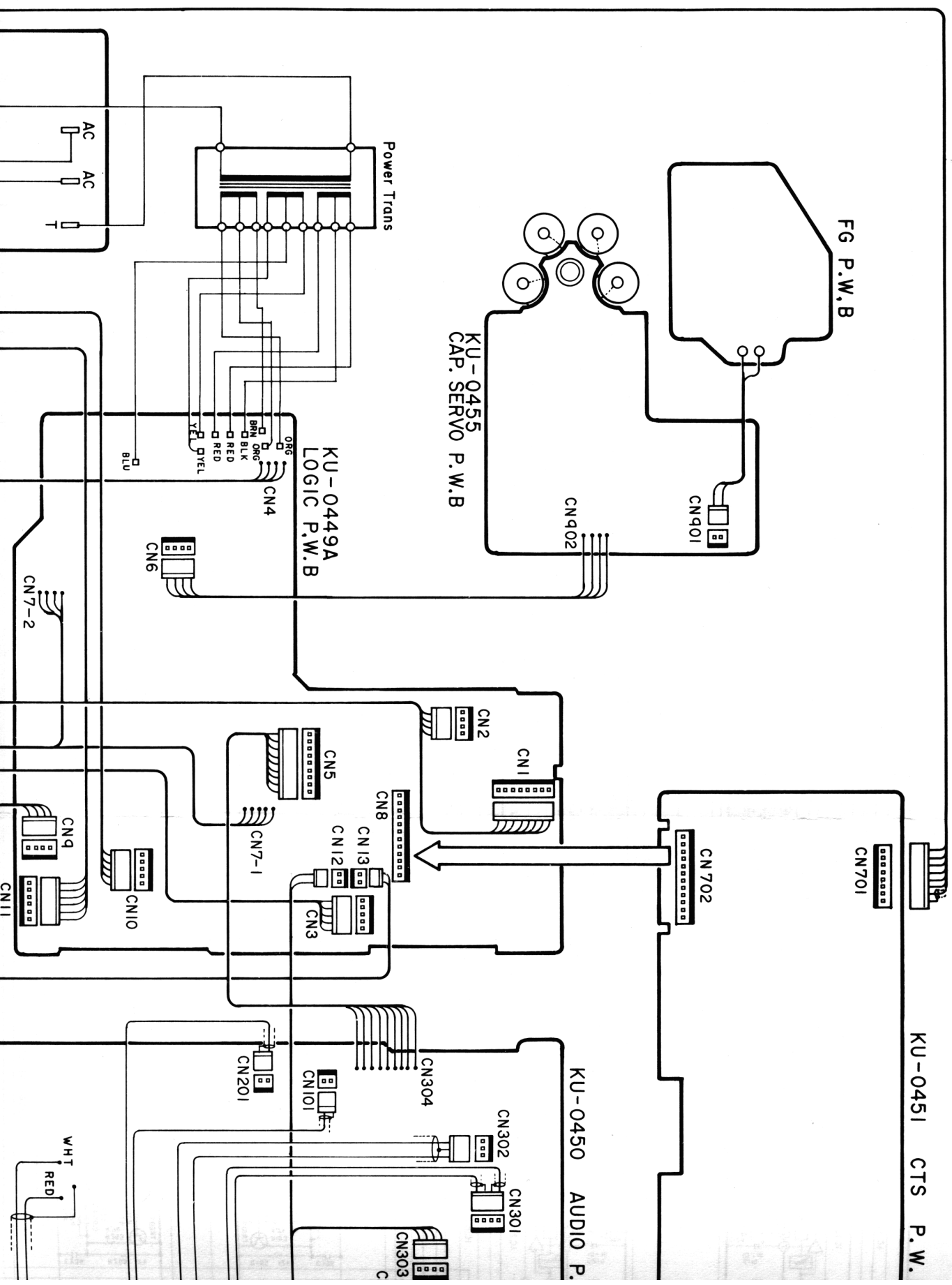

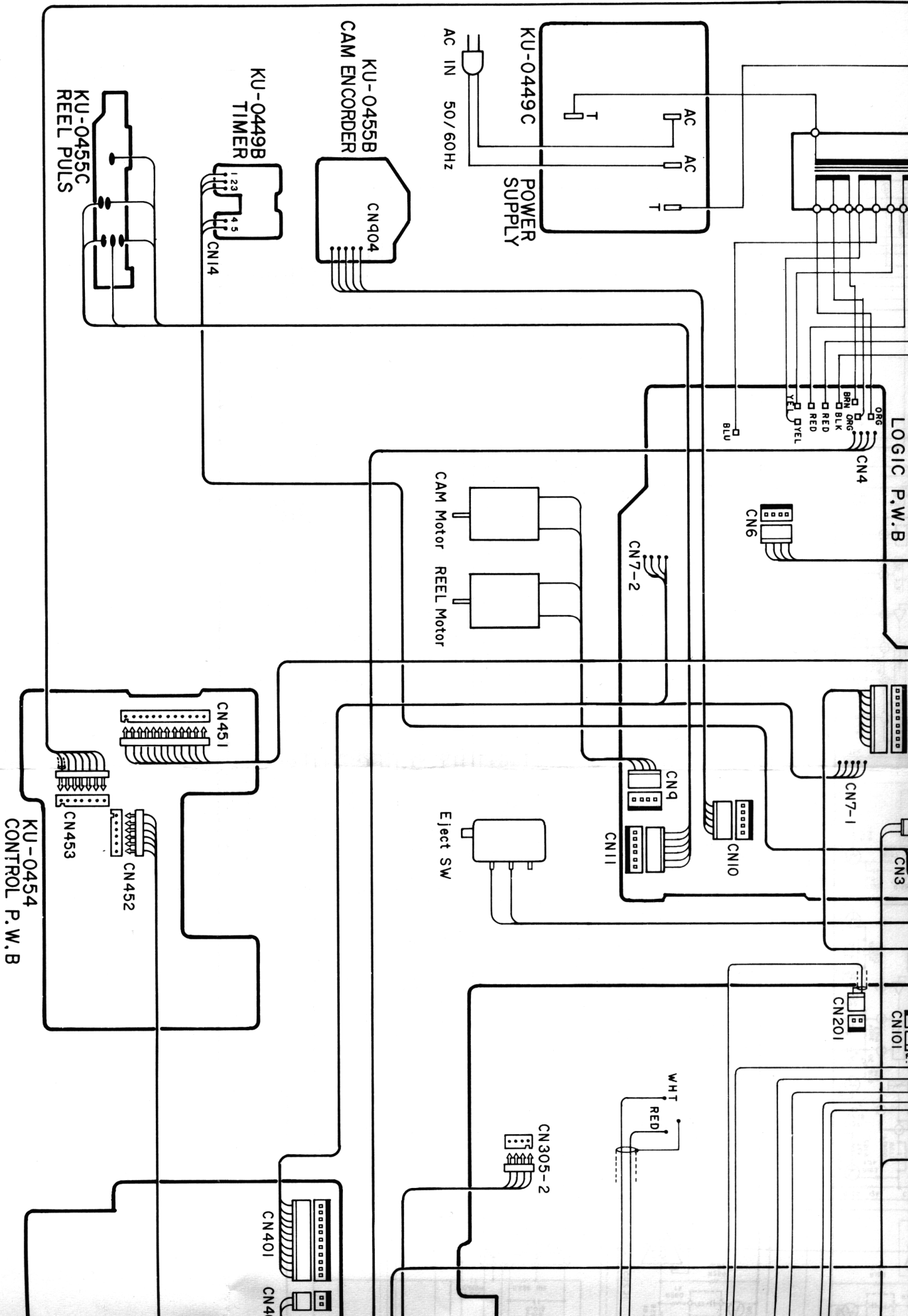

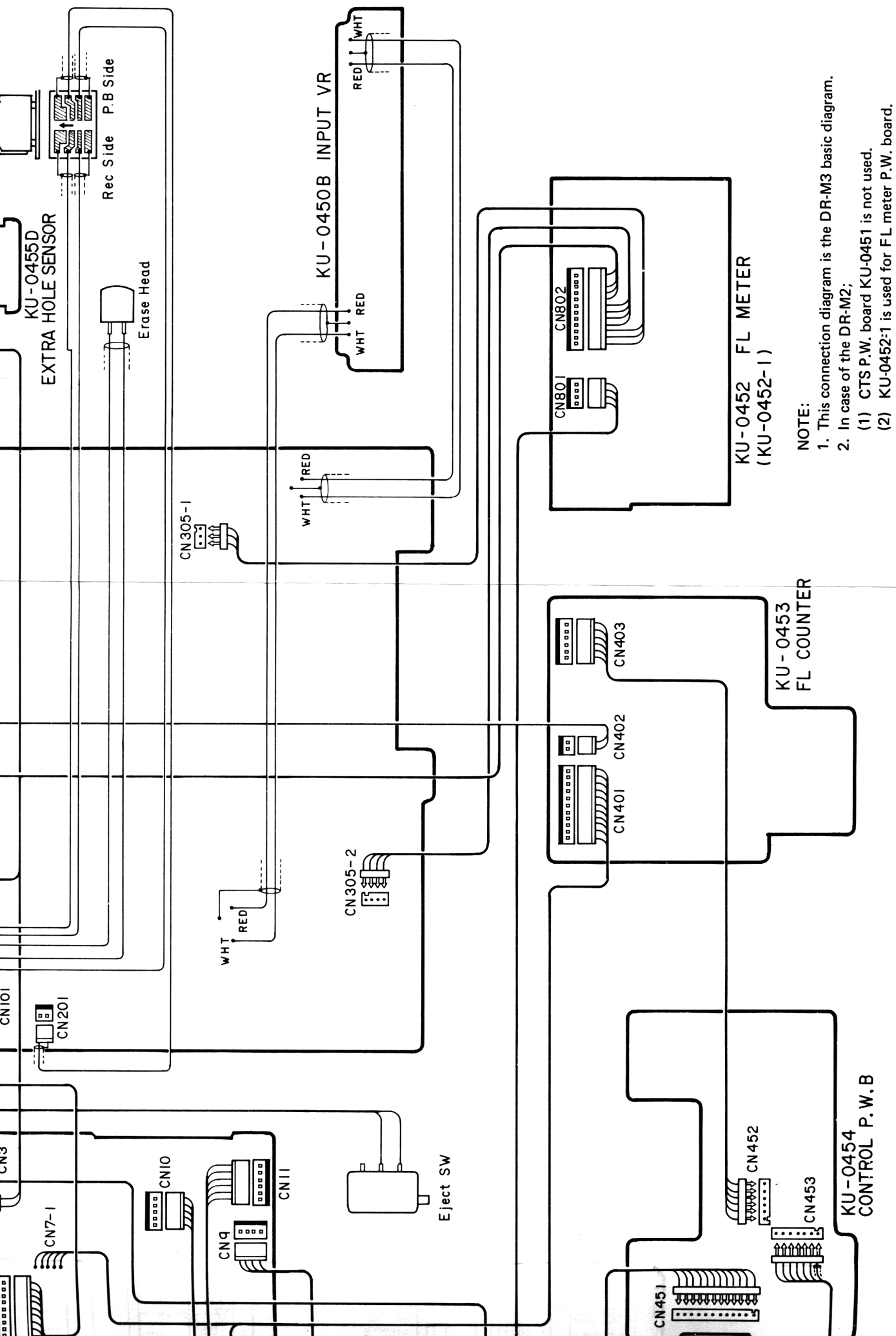

NOTE:

1. This connection diagram is the DR-M3 basic diagram.
2. In case of the DR-M2;
 - (1) CTS P.W. board KU-0451 is not used.
 - (2) KU-0452-1 is used for FL meter P.W. board.

KU-0451 CTS P.W.B

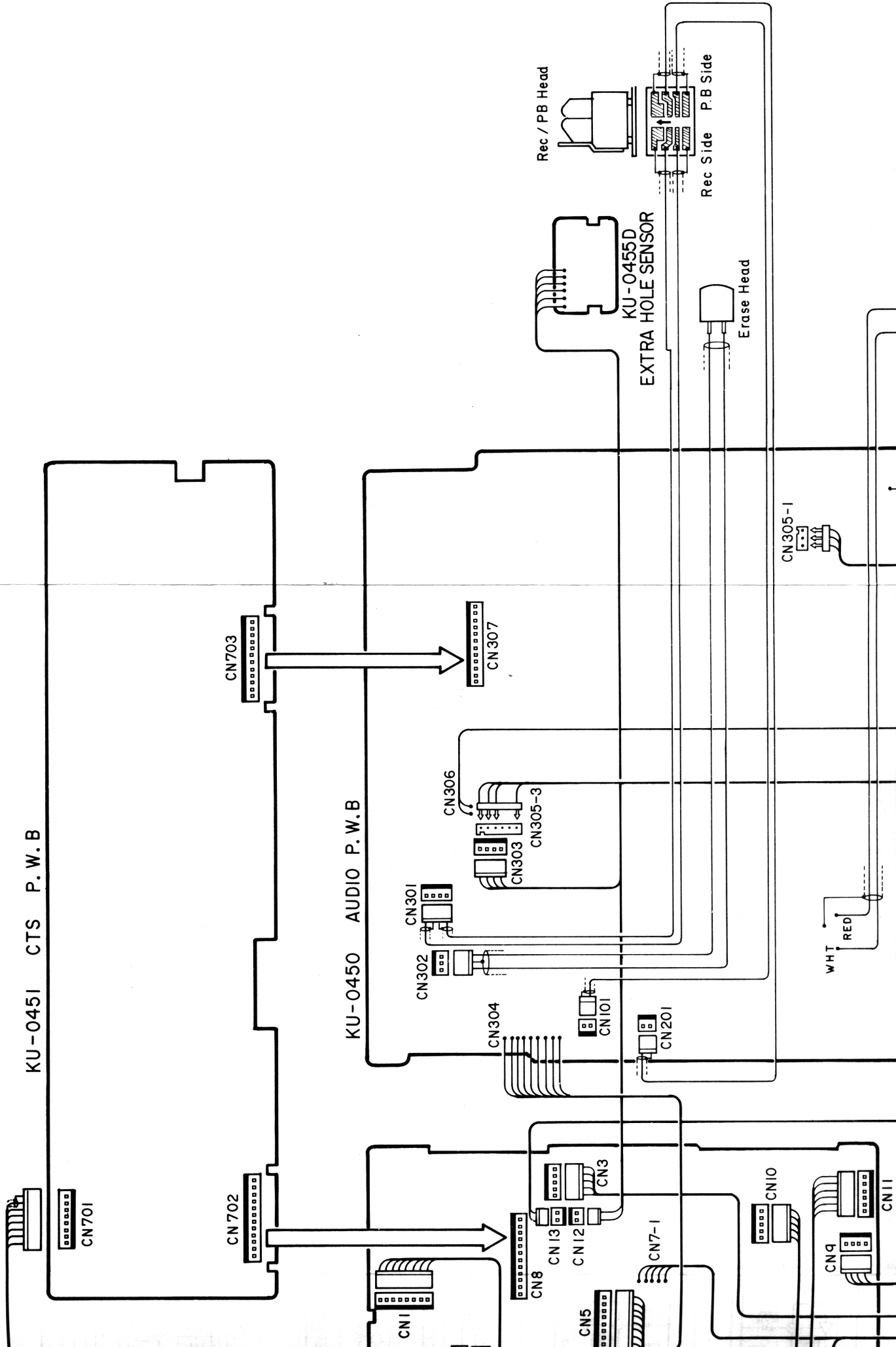

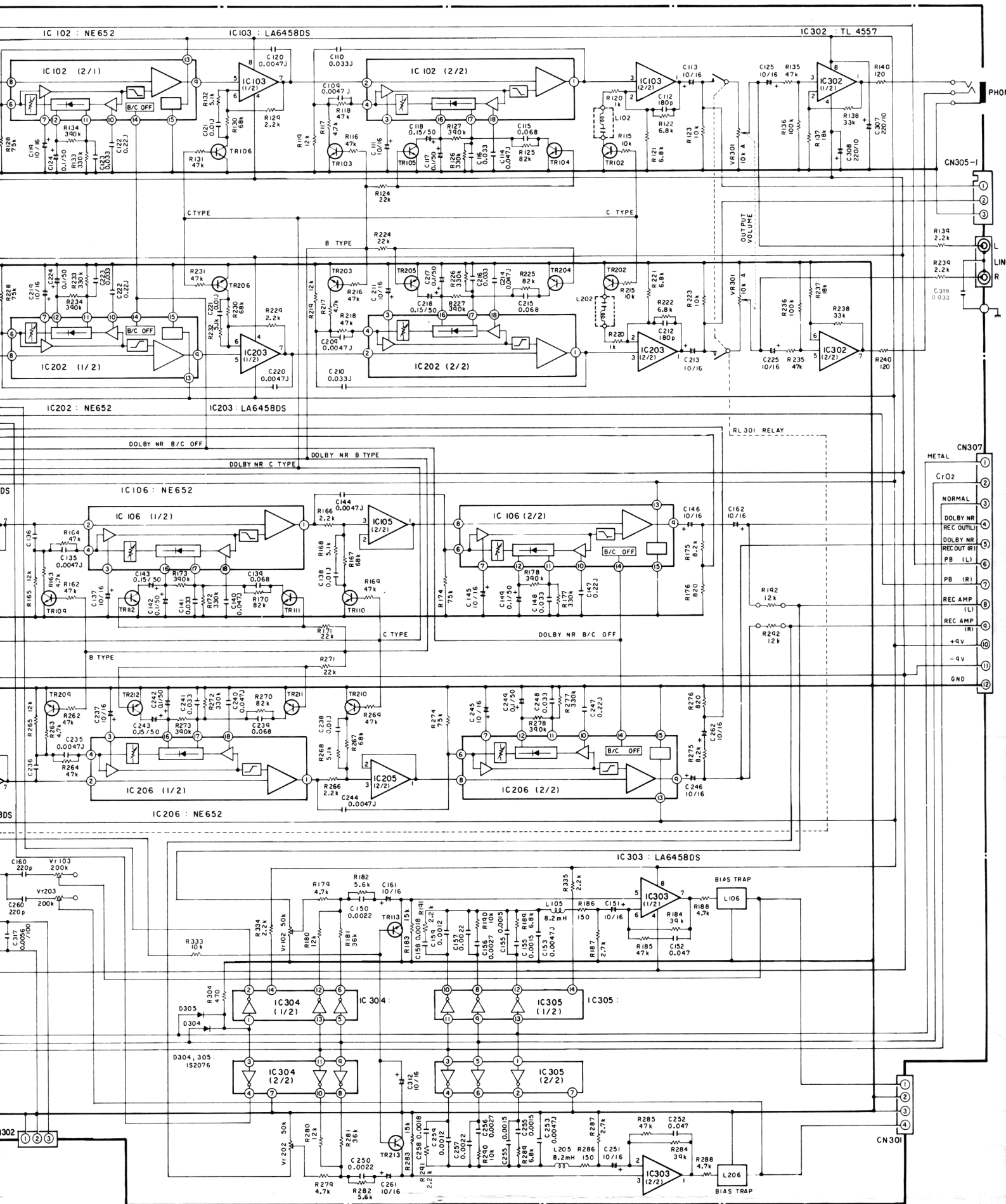

SCHEMATIC DIAGRAM OF AUDIO AMP UNIT

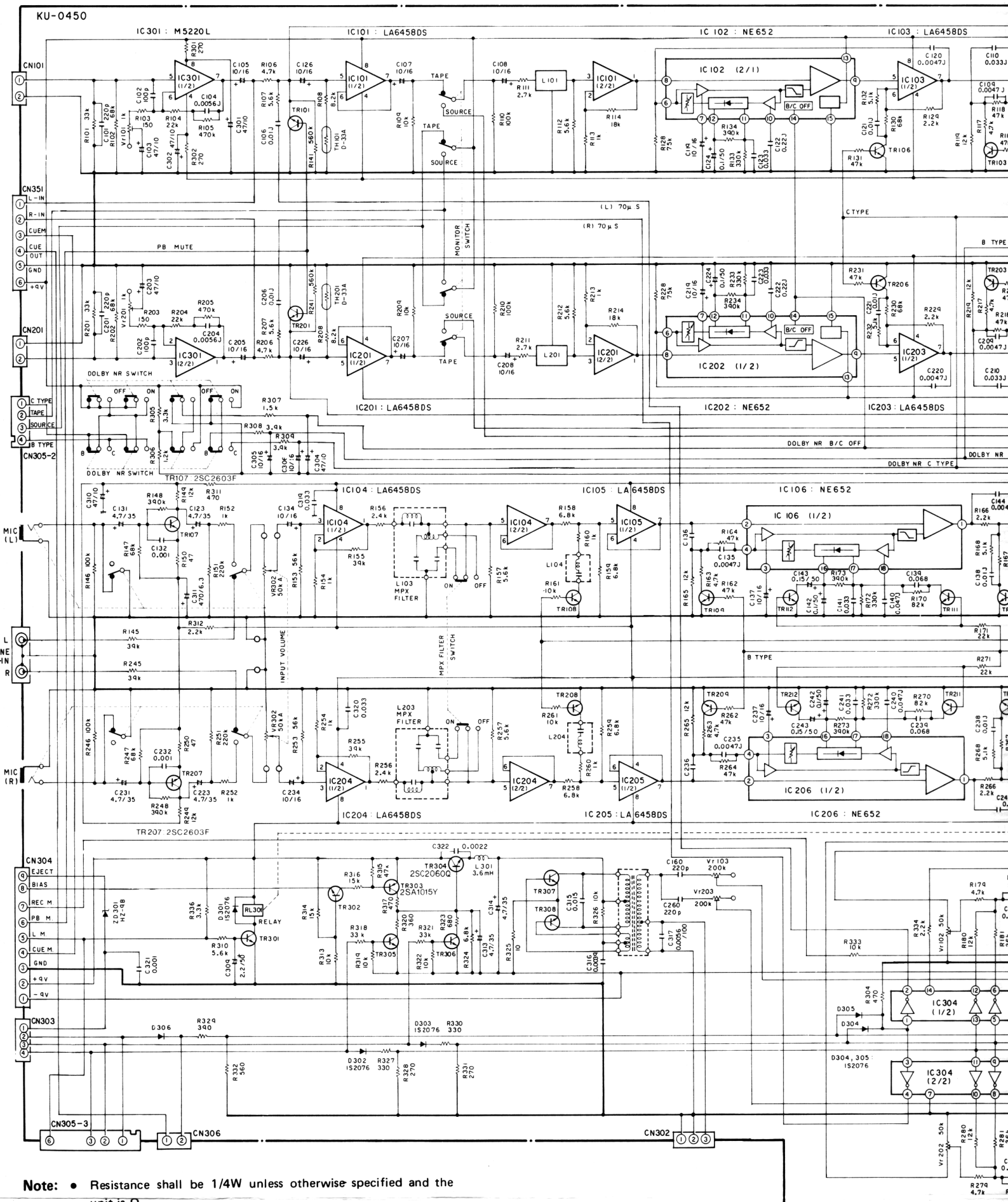

Note:

- Resistance shall be 1/4W unless otherwise specified and the unit is Ω .
- The unit of capacitor is μF , P is pF unless otherwise specified.
- This circuit diagram shows the basic circuit. It is subject to change for the purpose of improvement.

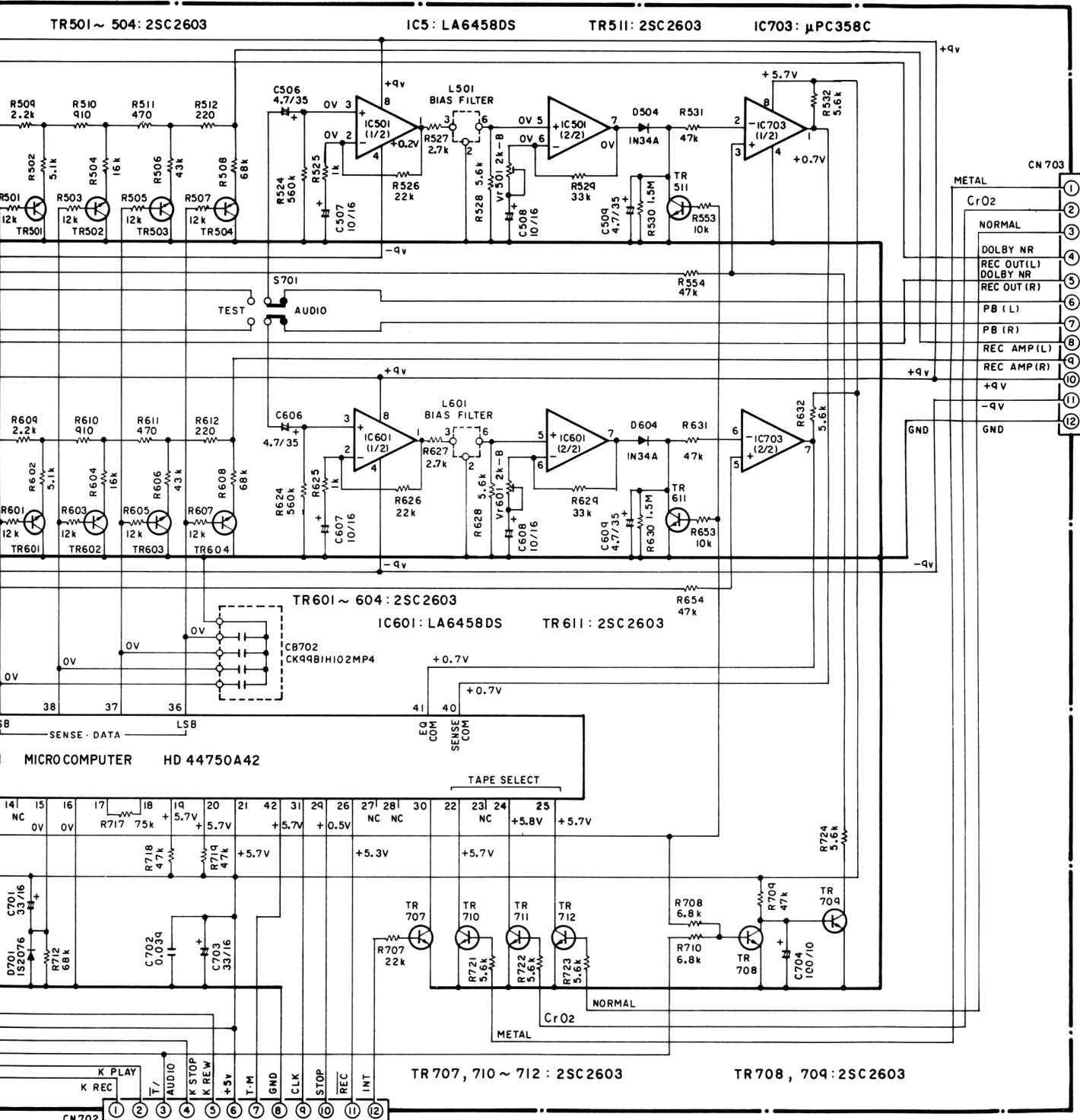

(DR-M2)

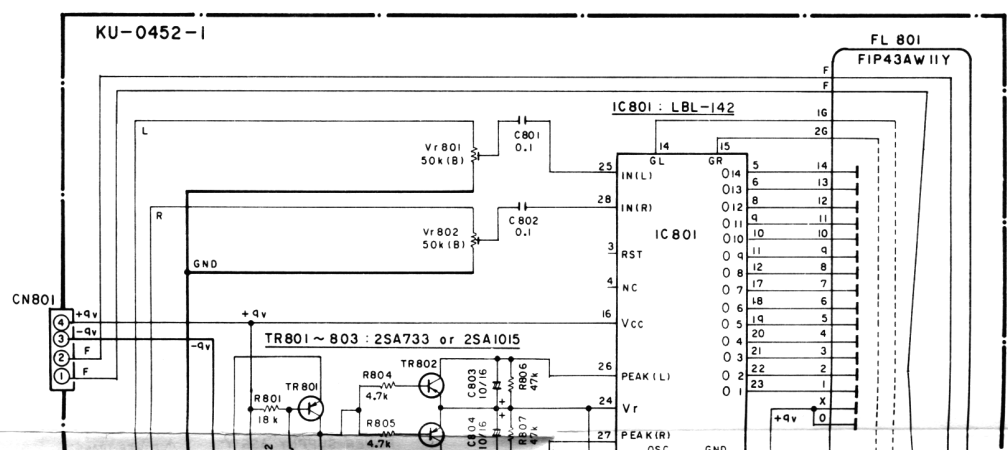

SCHEMATIC DIAGRAM OF CTS UNIT

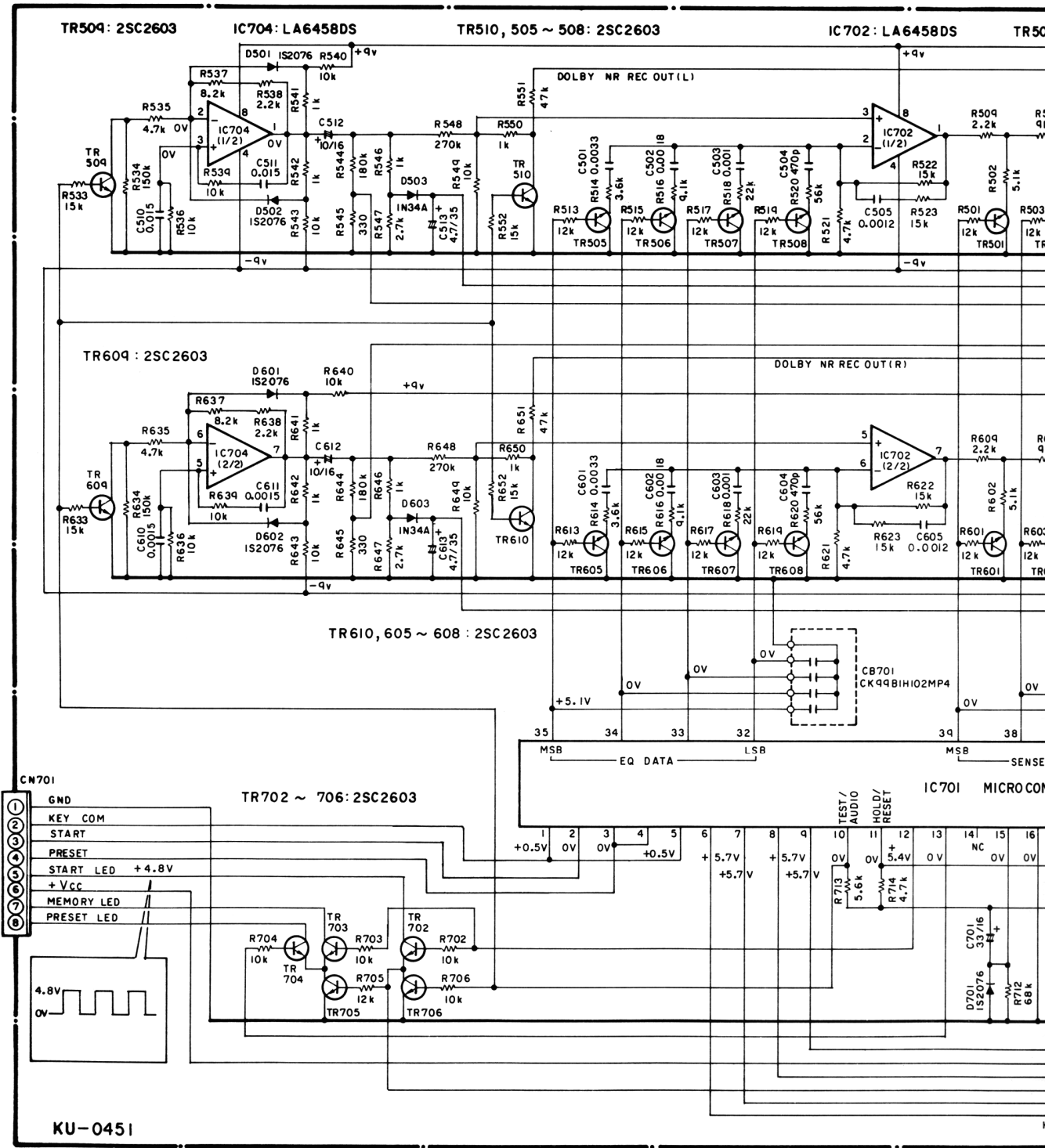

SCHEMATIC DIAGRAM OF FL METER UNIT

(DR-M3)

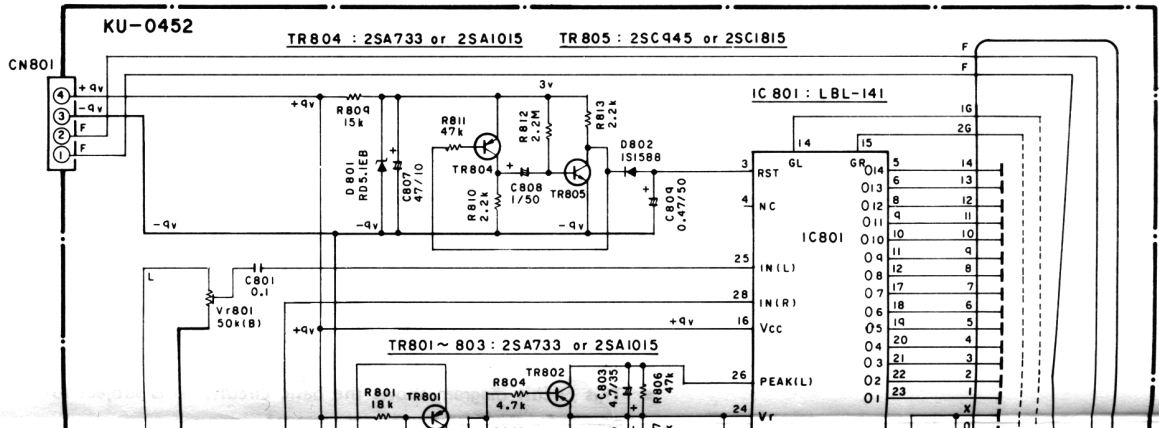

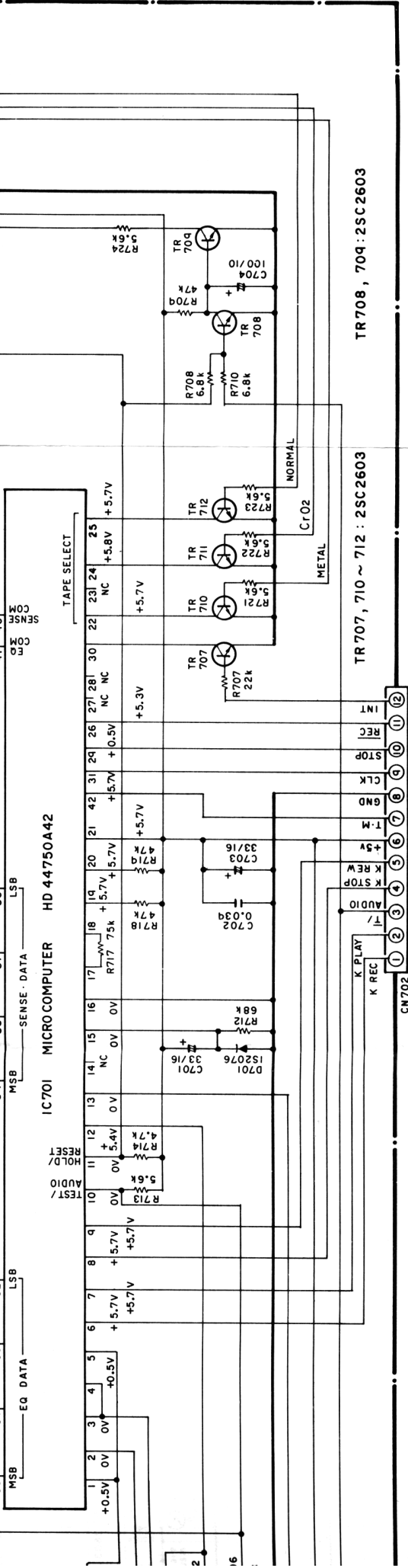

TR708, 709 : 2SC2603

TR707, 710 ~ 712 : 2SC2603

STER UNIT

(DR-M2)

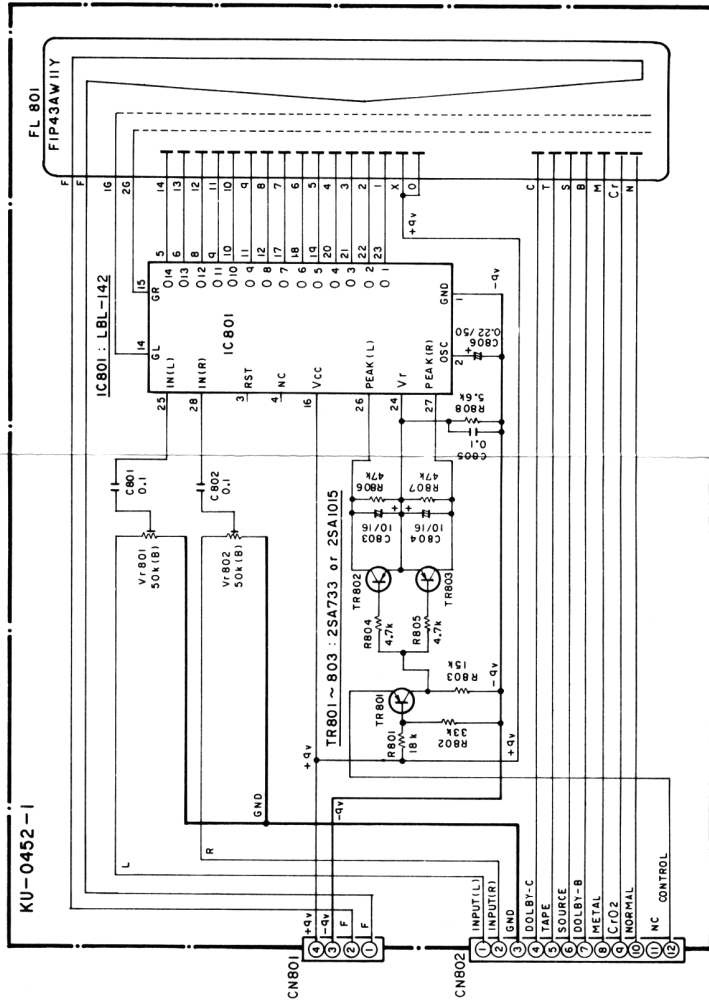

(DR-M3)

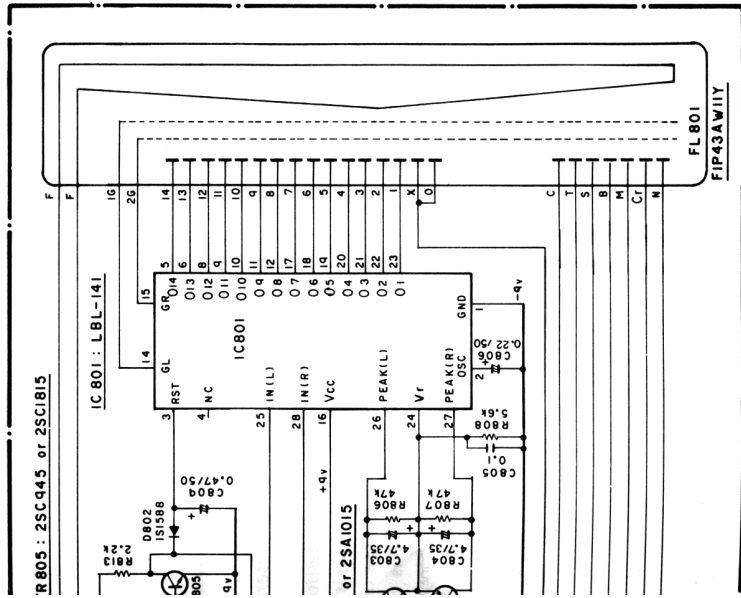

- Note:**
- Resistance shall be 1/4W unless otherwise specified and the unit is Ω .
 - The unit of capacitor is μF , P is pF unless otherwise specified.
 - This circuit diagram shows the basic circuit. It is subject to change for the purpose of improvement.

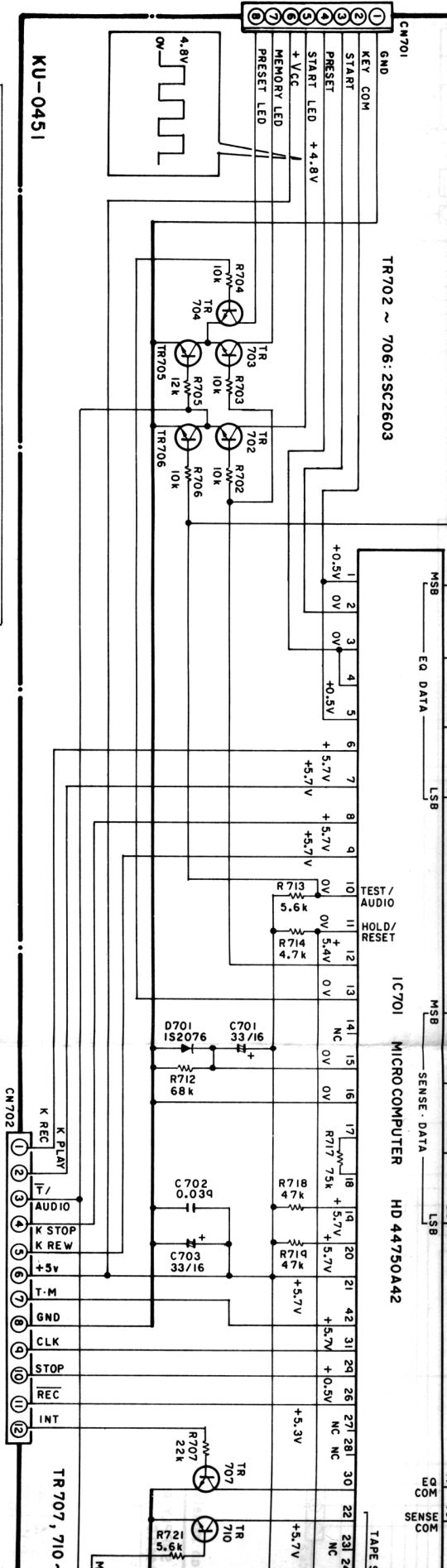

SCHEMATIC DIAGRAM OF FL METER UNIT

(DR-M3)

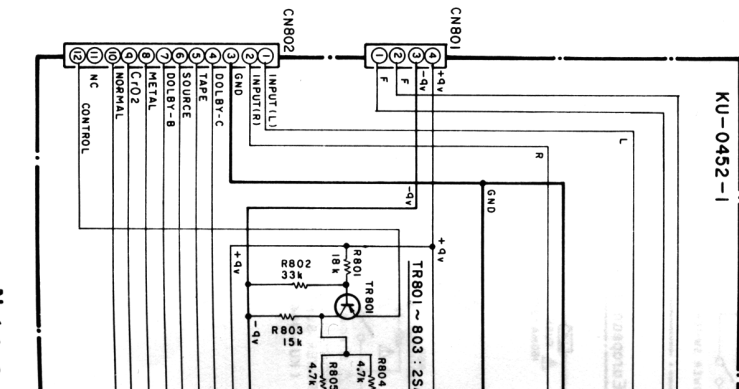
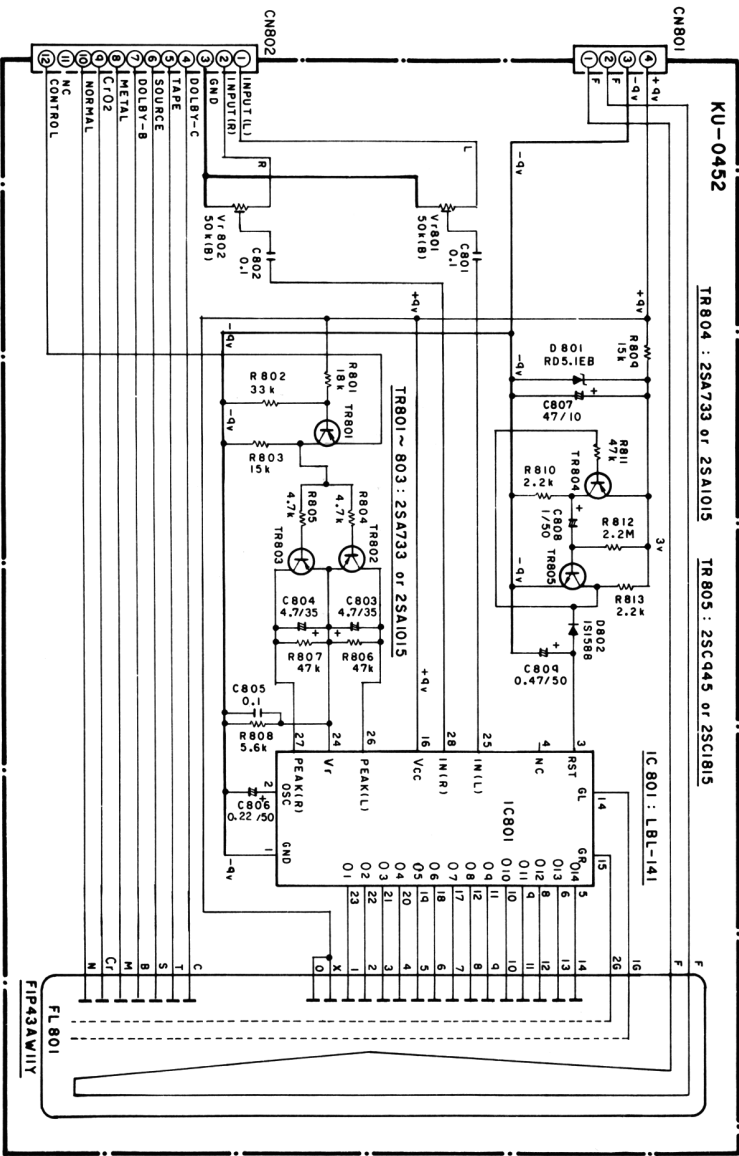

Note:

SCHEMATIC DIAGRAM OF LOGIC AND POWER UNIT

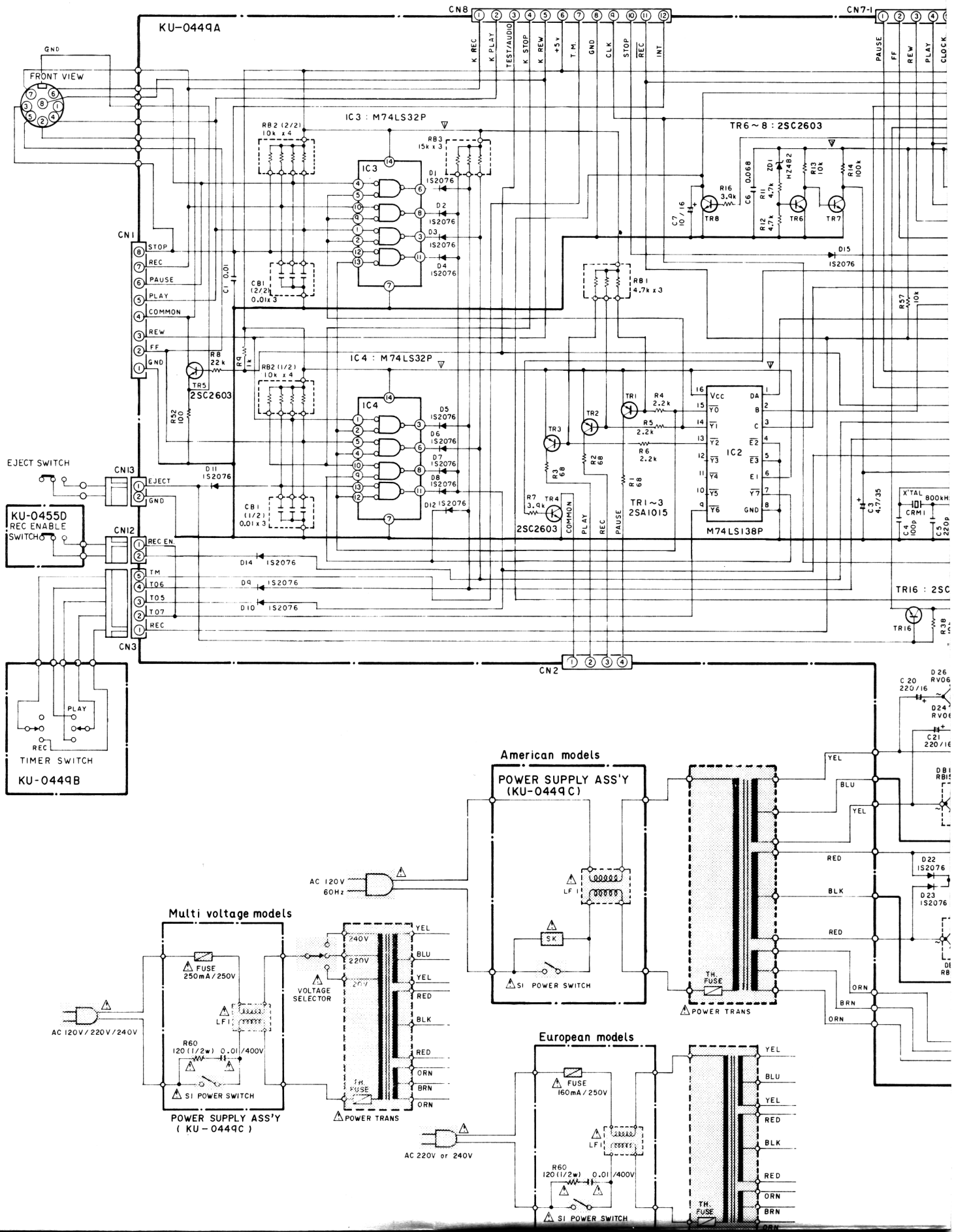

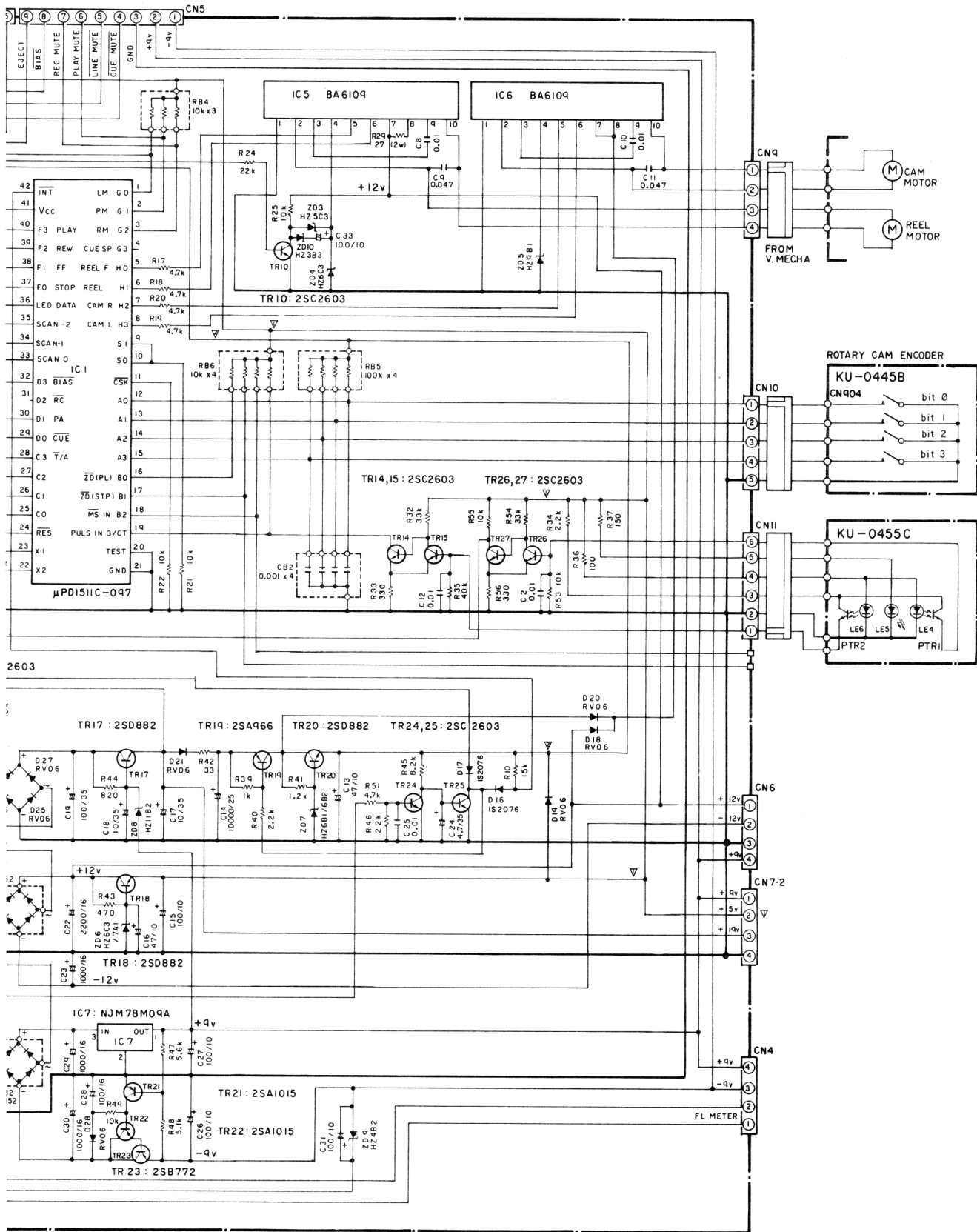

▽ +5V.
 ▽ The preserved power supply for the power off stop is

- Note:**
- Resistance shall be 1/4W unless otherwise specified and the unit is Ω.
 - The unit of capacitor is μF, P is pF unless otherwise specified.
 - This circuit diagram shows the basic circuit. It is subject to

SCHEMATIC DIAGRAM OF FL COUNTER UNIT

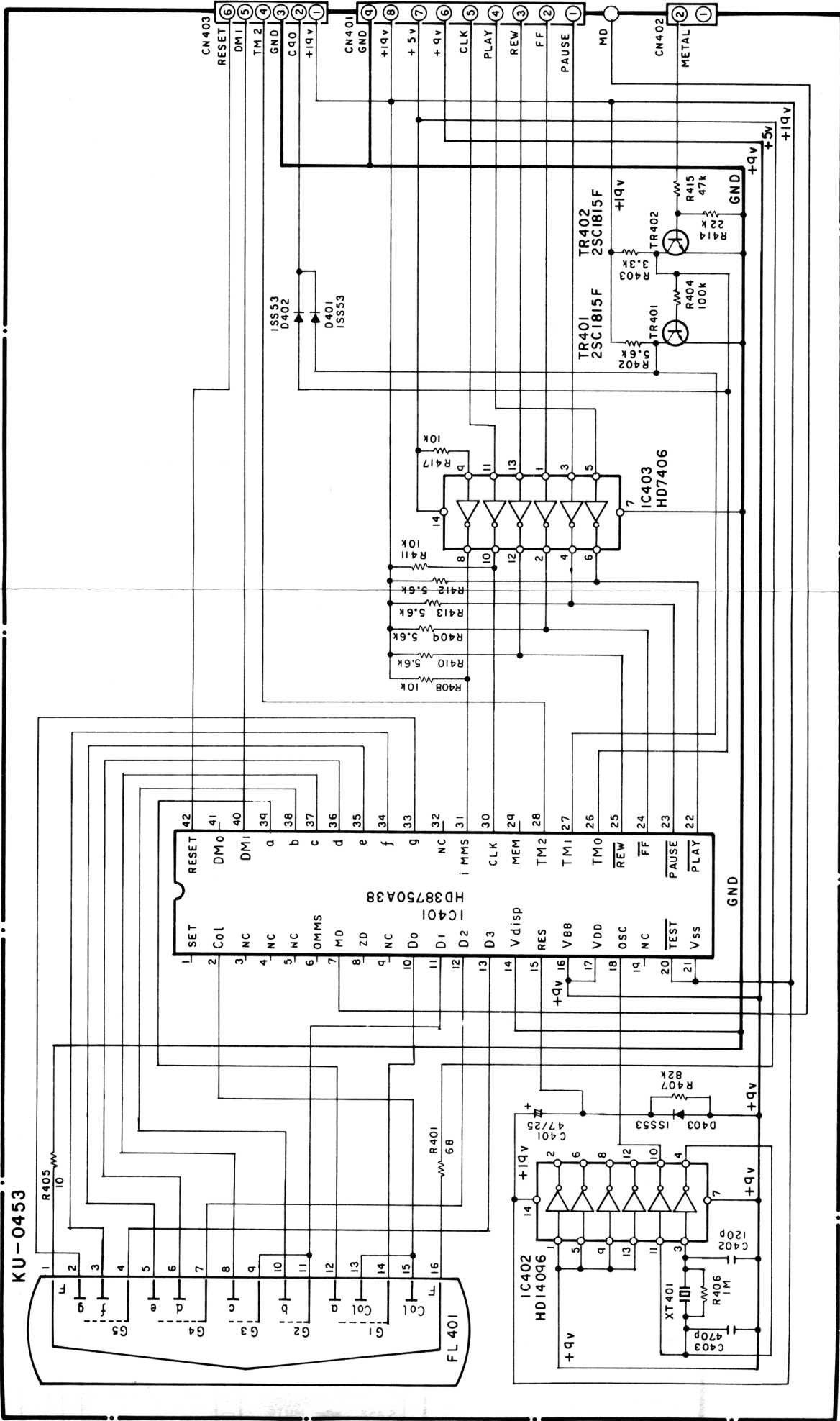

- Note:**
- Resistance shall be 1/W unless otherwise specified and the unit is Ω .
 - The unit of capacitor is μF , P is pF unless otherwise specified.
 - This circuit diagram shows the basic circuit. It is subject to change for the purpose of improvement.

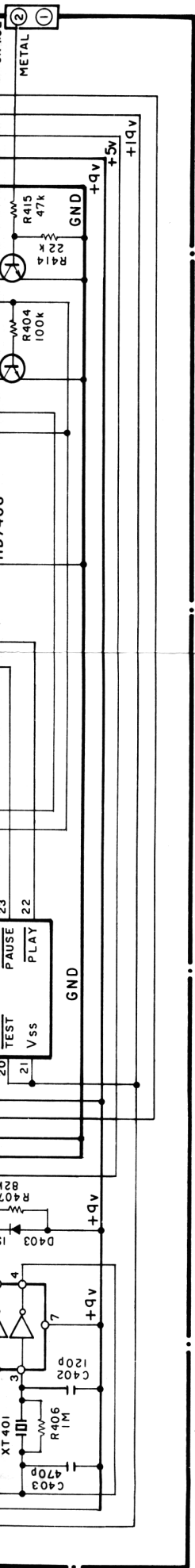

- Note:**
- Resistance shall be 1/4W unless otherwise specified and the unit is Ω .
 - The unit of capacitor is μF , P is pF unless otherwise specified.
 - This circuit diagram shows the basic circuit. It is subject to change for the purpose of improvement.

FL COUNTER CPU Terminal Function Table (IC401: HD38750A38)

Terminal number	Name	Input/output	Function	Terminal voltage (V)		Terminal number	Name	Input/output	Function	Terminal voltage (V)	
				STOP	COUNTER					STOP	COUNTER
1	SET (NC)		NON CONNECTION	0.05	0.04	25	REW	Input	Rewind signal terminal	17.7	17.7
2	COL	Output	Colon indication output terminal	0.05	0.04						
3	NC		NON CONNECTION	0.05	0.04						
4	NC		"	0.04	0.04						
5	NC		"	0.04	0.04						
6	OMMS (NC)		"	0.04	0.03	26	TM ₀	Input	Tape (length) mode terminal C-60 MC-60 C-90 C-120 LC-46 LMC-46	0.09	0.09
7	MD (NC)		"	0.04	0.04	27	TM ₁	Input	H L L L L L L L L L	17.8	17.8
8	ZD (NC)		"	0.04	0.04	28	TM ₂	Input	L H L L L L L L L L	0	0
9	TEO (NC)		"	0.04	0.04	29	MEM (NC)		NON CONNECTION	0.06	0.06
10	D ₀	Output	"	0.04	0.03	30	CLK	Input	Counter pulse terminal	18.8	0
11	D ₁	Output	"	0.9	0.9	31	IMMS (NC)		NON CONNECTION	0.06	0.06
12	D ₂	Output	Display tube grid terminal	0.9	0.9	32	NC		"	0.06	0.06
13	D ₃	Output	"	0.9	0.9	33	g	Output		0.05	0.05
14	Vdisp	Input	Power input terminal for the display tube: OV (GND)	0.9	0.9	34	f	Output		0.05	0.05
15	RST	Input	RESET terminal for the microcomputer	0	0	35	e	Output		18.7	18.7
16	VBB	Input	Power input terminal for the microcomputer	8.6	8.6	36	d	Output	Display tube data output terminal	18.7	18.7
17	VDD	Input	Power input terminal: 10V	8.7	8.7	37	c	Output		18.7	18.7
18	OSC	Input	OSC pulse terminal for the microcomputer	8.7	8.7	38	b	Output		18.7	18.7
19	NC		NON CONNECTION	13.6	13.6	39	a	Output		18.7	18.7
20	TEST	Input	Microcomputer TEST	-	-				Display mode terminal		
21	VSS	Input	Power earth input terminal: 19V	18.8	18.8				COUN-TER		
22	PLAY	Input	Record/Play signal terminal	18.8	18.8	40	DM ₀	Input	REM		
23	PAS	Input	Pause signal terminal	17.7	0.09	41	DM ₁	Input	STOP		
24	FF	Input	Fast forward signal terminal	17.7	17.7	42	RESET	Input	WATCH		
				17.7	17.7				MMS		
									Display tube zero-reset terminal		
									When RESET is pushed:		
										18.8	18.8

Mechanism-Control Microcomputer Terminal Function Table (IC₁: μ PD1511C-097)

Terminal number	Name	Input/output	Function	Terminal voltage (V)		
				STOP	PLAY	REC
1	$\overline{\text{LM}}$	Output	LINE MUTE terminal (Active LOW)	0	—	—
2	PM	Output	PLAY MUTE terminal (Active HIGH)	3.7	0	—
3	RM	Output	REC MUTE terminal (Active HIGH)	3.7	—	0
4	CUE SP (NC)	Output	NON CONNECTION	0	0	0
5	REEL F	Output	REEL MOTOR FORWARD terminal	0	3.6	—
6	REEL R	Output	REEL MOTOR REVERSE terminal	0	—	—
7	$\overline{\text{CAR R}}$	Output	CAM MOTOR RIGHT terminal	3.6	—	—
8	$\overline{\text{CAM L}}$	Output	CAM MOTOR LEFT terminal	3.6	—	—
9	NC		NON CONNECTION	0	—	—
10	NC		NON CONNECTION	0	—	—
11	NC		NON CONNECTION	0	—	—
12	A ₀	Input	CAM ENCODER DATA terminal	0	0.5	—
13	A ₁	Input		4.9	—	—
14	A ₂	Input		4.9	0	—
15	A ₃	Input		0	4.9	—
16	$\overline{\text{ZE (PL) (NC)}}$	Input	NON CONNECTION	5.7	—	—
17	$\overline{\text{ZD (STP) (NC)}}$	Input	NON CONNECTION	5.7	—	—
18	$\overline{\text{MS IN (NC)}}$	Input	NON CONNECTION	5.7	—	—
19	PULS IN	Input	REEL PULSE terminal	0.6	—	—
20	TEST	Input	Microcomputer TEST terminal	0	—	—
21	GND	Input	GND	0	—	—
22	X ₂	Input	OSC terminal for the microcomputer	1.9	—	—
23	X ₁	Input		2.0	—	—
24	$\overline{\text{RES}}$	Input	RESET terminal	4.9	—	—
25	C ₀	Input	KEY MATRIX input terminal	5.7	—	—
26	C ₁	Input		5.1	—	—
27	C ₂	Input		5.0	—	—
28	$\overline{\text{T/A}}$	Input	TEST/AUDIO terminal	4.6	—	—
29	$\overline{\text{CUE (NC)}}$	Output		0	0.1	0.1
30	PA	Output	PAUSE STATUS terminal	0.1	—	—
31	$\overline{\text{RC}}$	Output	REC STATUS terminal	0	—	—
32	$\overline{\text{BIAS}}$	Output	BIAS control terminal	5.2	—	0.1
33	LED DATA	Output	LED control terminal	2.0	—	—
34	E ₁	Output	Output terminal for KEY MATRIX	2.0	—	—
35	E ₂	Output		2.0	—	—
36	E ₃	Output		0	0.5	0.9
37	STP	Output	STOP STATUS terminal	5.4	0	0
38	FF	Output	FF STATUS terminal	0.1	—	—
39	FW	Output	REW STATUS terminal	0.1	—	—
40	PL	Output	PLAY STATUS terminal	0.1	3.8	3.8
41	V _{cc}	Input	Power input terminal +5V	4.9	—	—
42	$\overline{\text{INT}}$	Input	Interrupt terminal	4.9	—	—

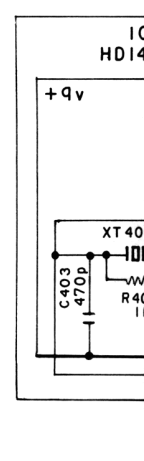
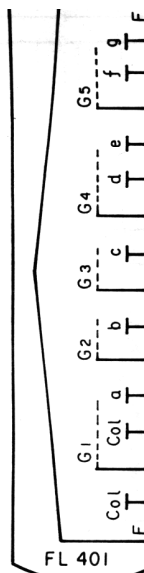

FL COUNTER CP

Terminal number	Name	Function
1	SET (NC)	
2	COL	
3	NC	
4	NC	
5	NC	
6	OMMS (NC)	
7	MD (NC)	
8	ZD (NC)	
9	TEO (NC)	
10	D ₀	
11	D ₁	
12	D ₂	
13	D ₃	
14	V _{disp}	
15	RST	
16	VBB	
17	VDD	
18	OSC	
19	NC	
20	TEST	
21	VSS	
22	$\overline{\text{PLAY}}$	
23	$\overline{\text{PAS}}$	

SCHEMATIC DIAGRAM OF CAPSTAN SERVO UNIT

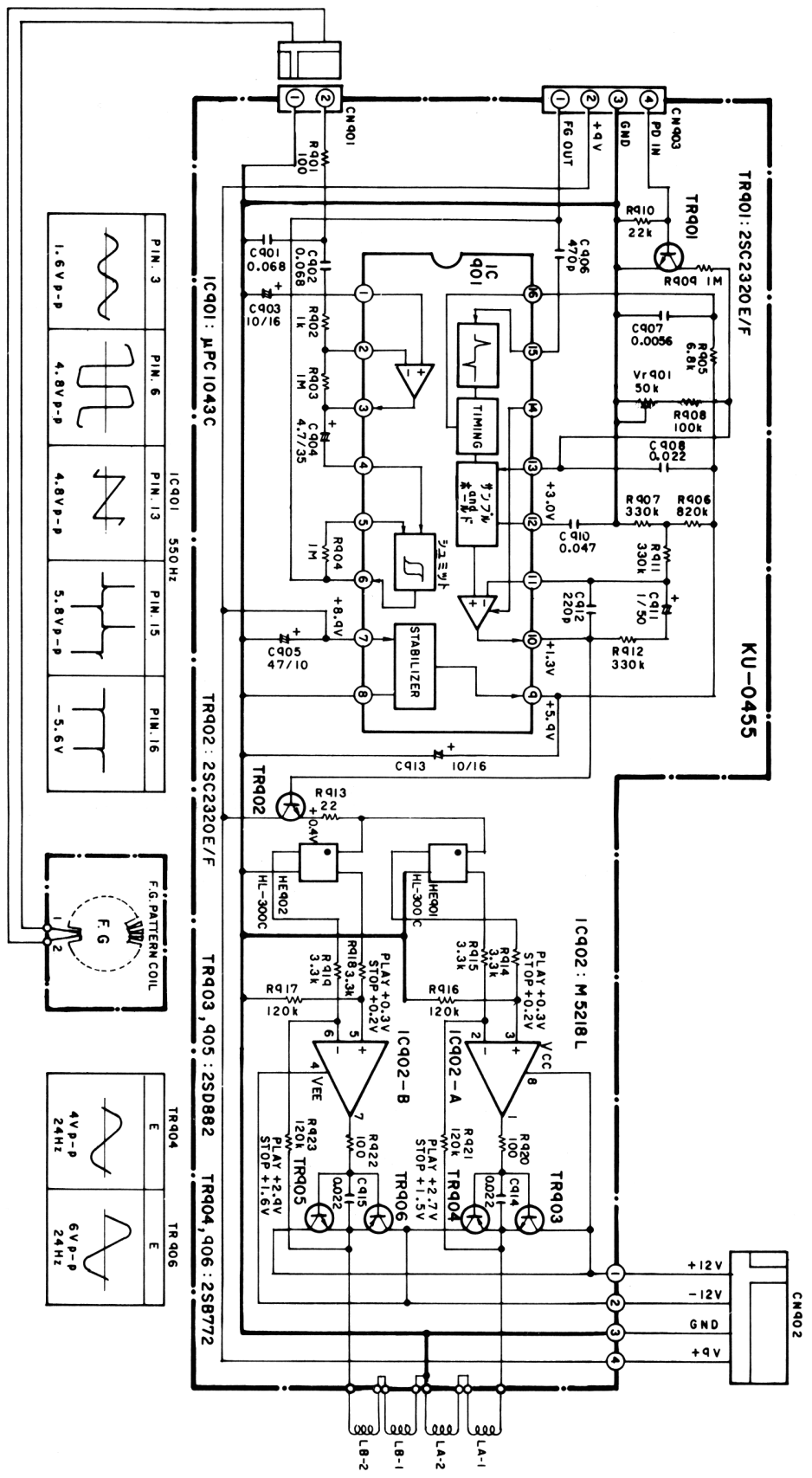

IC901: µPC1043C	IC901: 550HZ	TR902: 2SC2320E/F	TR903, 905: 2SD882	TR904, 906: 2SB772
PIN. 3	PIN. 6	PIN. 13	PIN. 15	PIN. 16

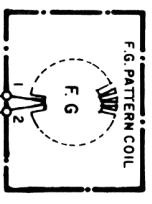

TR904	TR906

LEAD CONNECTION OF SEMICONDUCTORS



SCHEMATIC DI

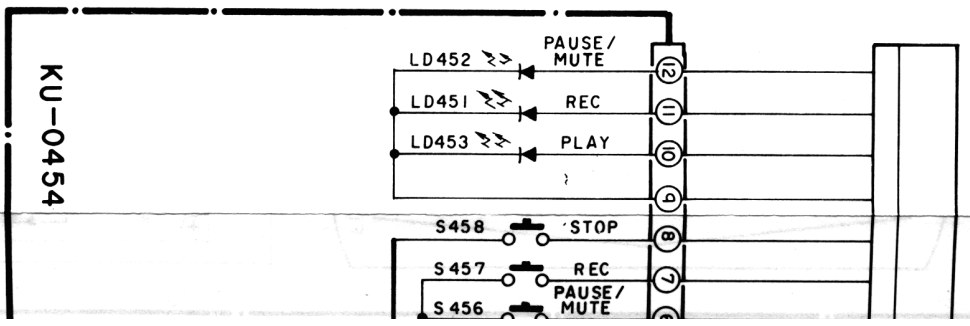

SCHEMATIC DIAGRAM OF CONTROL UNIT

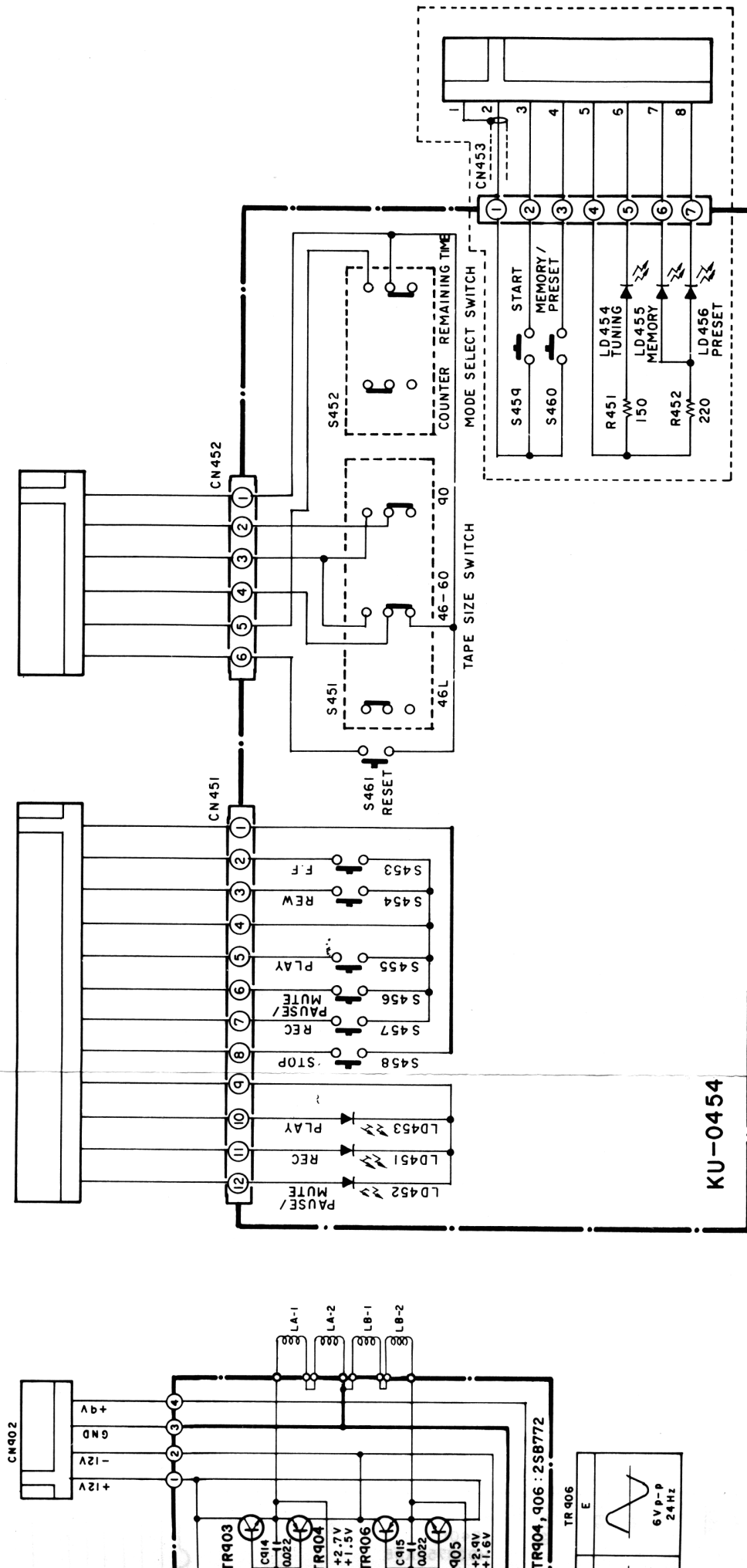

- Note:**
- Resistance shall be 1/4W unless otherwise specified and the unit is Ω .
 - The unit of capacitor is μF , P is pF unless otherwise specified.
 - This circuit diagram shows the basic circuit. It is subject to change for the purpose of improvement.



LEAD CONNECTION OF SEMICONDUCTORS



- 1S2076
- 1N34A
- 1S1588
- 1SS53
- RB3-0EB2



- HZ4B2
- HZ5A2
- HZ5C3
- HZ6B1
- HZ6C3
- HZ7A3
- HZ9B1
- HZ11B2



RV06



- 2SA733
- 2SA1015Y/GR
- 2SC2603E/F
- 2SC1815GR
- 2SC2060Q
- 2SC2320E/F
- 2SA966Y
- 2SC945P

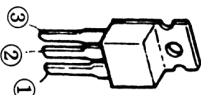
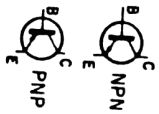

NJM78M09A



2SB772Q/P
2SD882Q/P

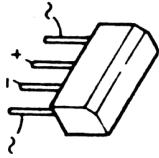

RB152

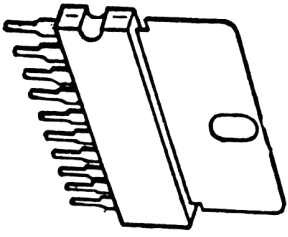

BA6109

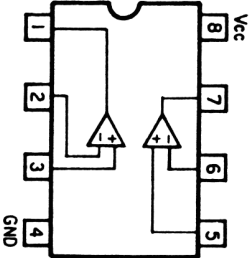

- μPC358C
- μPC457C
- LA6458DS

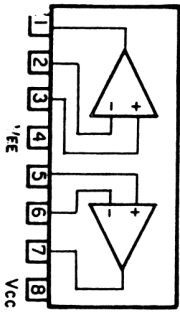

- M5218L
- M5220L

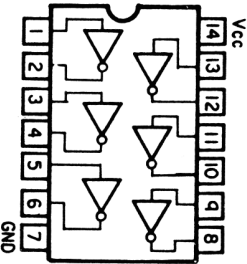

- M74LS05P
- HD14069UBP
- HD7406

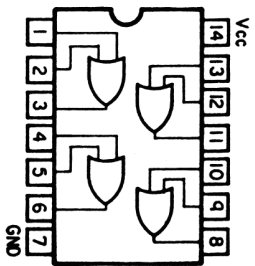

M74LS32P

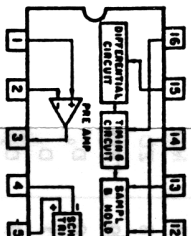

1	2	3	4	5	6	7	8	9	10	11	12	13	14	15
16	17	18	19	20	21	22	23	24	25	26	27	28	29	30

- Note:**
- Resistance shall be 1/4W unless otherwise specified and the unit is Ω .
 - The unit of capacitor is μF , P is pF unless otherwise specified.
 - This circuit diagram shows the basic circuit. It is subject to change for the purpose of improvement.

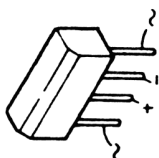

RB 152



SB772Q/P

SD882Q/P

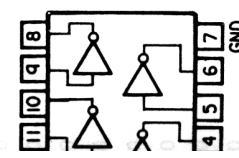

M74LS32P

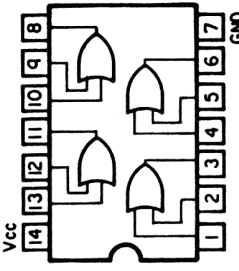

M74LS32P

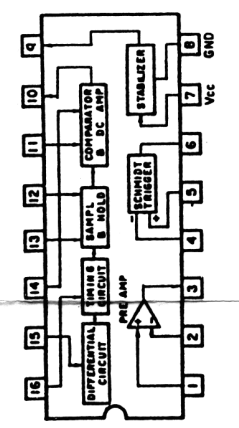

PC1043C

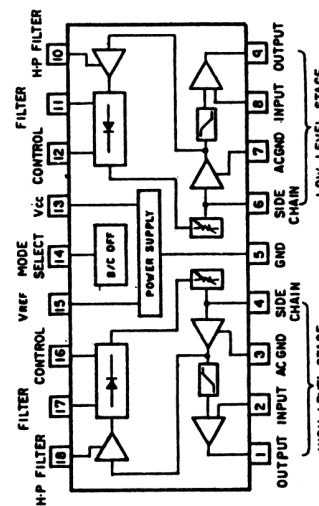

NE652

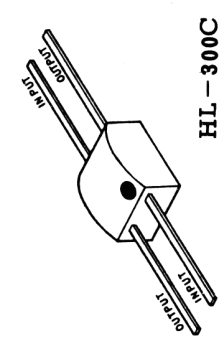

HL-300C

DENON

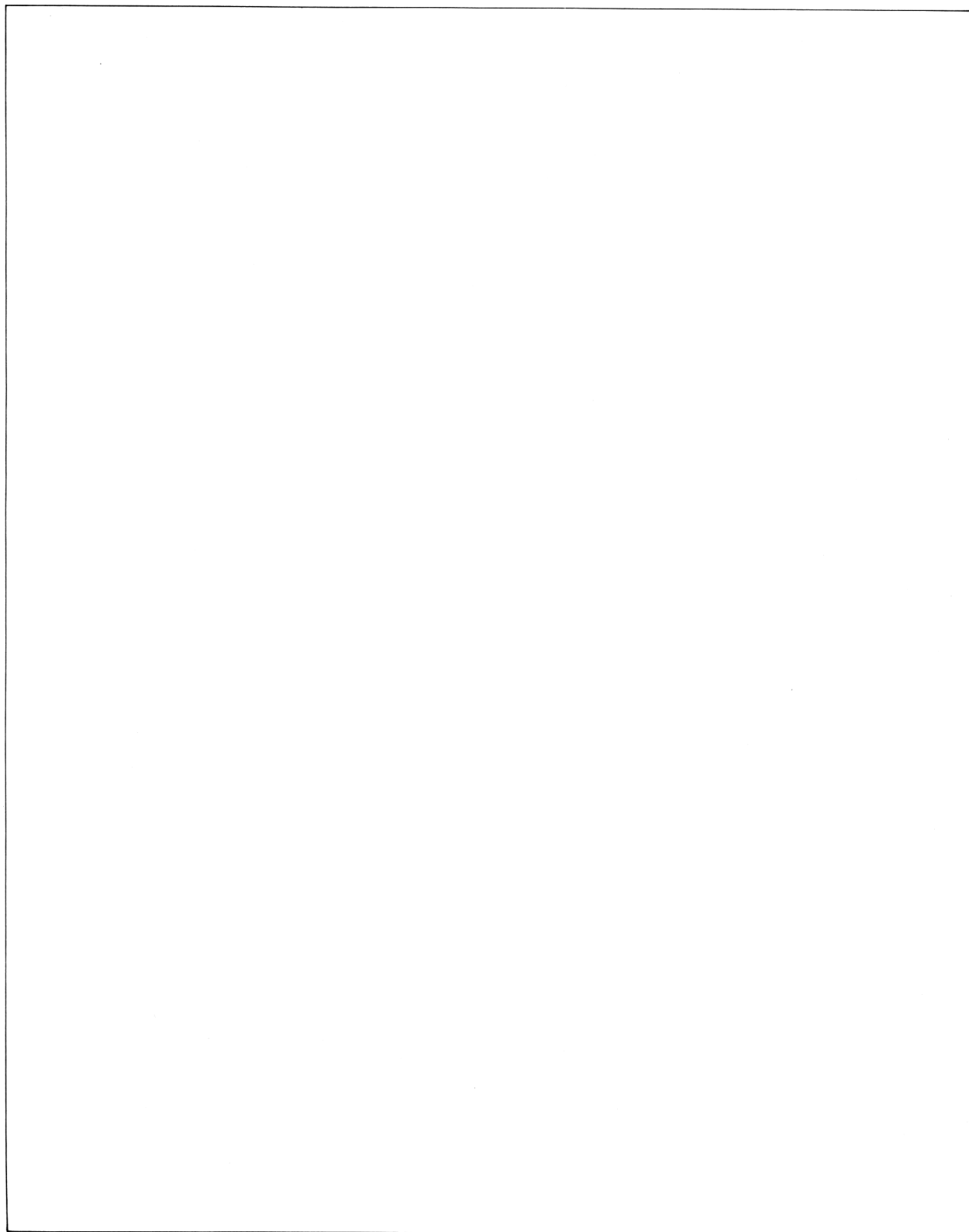

NIPPON COLUMBIA CO., LTD.

No. 14-14, 4-CHOME AKASAKA,
MINATO-KU, TOKYO JAPAN

TEL: 03-584-8111

TLX: JAPANOLA J22591

CABLE: NIPPON COLUMBIA TOKYO