

Service Manual

Dolby NR-Equipped
Stereo Cassette Deck

Cassette Deck
RS-B965

 **DOLBY B·C NR HX PRO**

Color

(K)... Black Type

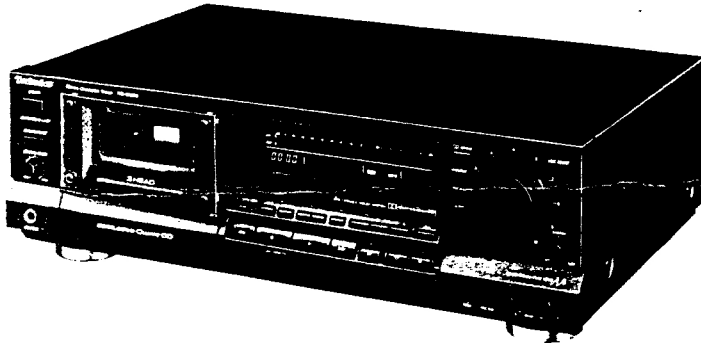

Area

Country Code	Area	Color
(E)	Continental Europe.	(K)
(EB)	Great Britain.	
(EG)	F.R. Germany and Italy.	
(GC)	Asia, Latin America, Near East, and Africa.	
(GN)	Oceania.	

* HX Pro headroom extension originated by Bang Olufsen and manufactured under license from Dolby Laboratories Licensing Corporation. "DOLBY", the double-D symbol, and "HX PRO" are trademarks of Dolby Laboratories Licensing Corporation.

RS-B755 MECHANISM SERIES (AR350)

■ SPECIFICATIONS

■ CASSETTE DECK SECTION

Deck system	Stereo cassette deck
Track system	4-track, 2-channel
Heads	
Record	Permalloy (Combination)
Playback	Permalloy (Combination)
Erasure	Double-gap ferrite
Motors	
Capstan drive	Quartz DD motor
Reel table drive	DC motor
Cassette holder open/close	DC motor
Recording system	AC bias
Bias frequency	80 kHz
Erasing system	AC erase
Tape speed	
Frequency response	4.8 cm/sec.
NORMAL	20 Hz~19 kHz
CrO ₂	20 Hz~18 kHz (DIN)
METAL	20 Hz~20 kHz
	20 Hz~19 kHz (DIN)
	20 Hz~21 kHz
	20 Hz~20 kHz (DIN)
S/N (signal level=max recording level, CrO ₂ type tape)	
Dolby C NR on	74 dB (CCIR)
Dolby B NR on	66 dB (CCIR)
Dolby NR off	57 dB (A weighted)

Wow and flutter 0.05% (WRMS)
±0.14% (DIN)

Fast forward and rewind times
Approx. 90 seconds with C-60 cassette tape

Input sensitivity and impedance
LINE 60 mV/47 kΩ

Output voltage and impedance
LINE 400 mV/800Ω
HEADPHONES 125 mV/8Ω
(8Ω~600Ω)

■ GENERAL

Power consumption 21 W

Power supply

For Continental Europe, F.R. Germany and Italy

AC 50 Hz/60 Hz, 220 V

For Great Britain and Oceania

AC 50 Hz/60 Hz, 240 V

For others

AC 50 Hz/60 Hz, 110 V/127 V/220 V/240 V

Dimensions (W × H × D) 430 × 135 × 290 mm

Weight 6.4 kg

Note:

Specifications are subject to change without notice.

Weight and dimensions are approximate.

Technics

Matsushita Electric Industrial Co., Ltd.
Central P.O. Box 288, Osaka 530-91, Japan

CONTENTS

	Page
MAINTENANCE.....	2
ACCESSORIES.....	2
CONNECTIONS.....	3
FRONT PANEL CONTROLS AND FUNCTIONS.....	4, 5
RECORDING WITH HIGH TONE QUALITY.....	6~9
DISASSEMBLY INSTRUCTIONS.....	10~15
MEASUREMENT AND ADJUSTMENT METHODES....	16~21
TERMINAL FUNCTION OF IC'S.....	22, 23
BLOCK DIAGRAM.....	24~26
SCHEMATIC DIAGRAM.....	27~38
TROUBLESHOOTING OF DIRECT DRIVE MOTOR.....	38

	Page
TERMINAL GUIDE OF IC'S, TRANSISTORS AND DIODES.....	39
INTERNAL CONNECTION OF FL.....	40
WIRING CONNECTION DIAGRAM.....	41
PRINTED CIRCUIT BOARDS.....	42~46
REPLACEMENT PARTS LIST.....	47~50
EXPLODED VIEWS.....	51~54
REPLACEMENT PARTS LIST.....	55, 56
PACKING.....	56
RESISTORS & CAPACITORS.....	57~60
※ TECHNICAL INFORMATION	
※ This technical information is located on pp 45-51 of the RS-B555 Service Manual (Order No. AD8907231C5). Therefore, refer to that Service Manual.	

MAINTENANCE

Head care

To assure good sound quality for recording and playback, be sure to clean the heads after approximately every 10 hours of use.

- 1) Press the open/close button.
- 2) Press the power "standby (⏻)/on" switch to turn the unit off.
- 3) Clean the heads, pinch roller and the capstan shaft with a cotton swab (or with a soft, lint-free cloth) slightly moistened with alcohol.

Do not use any solution other than alcohol for head cleaning.

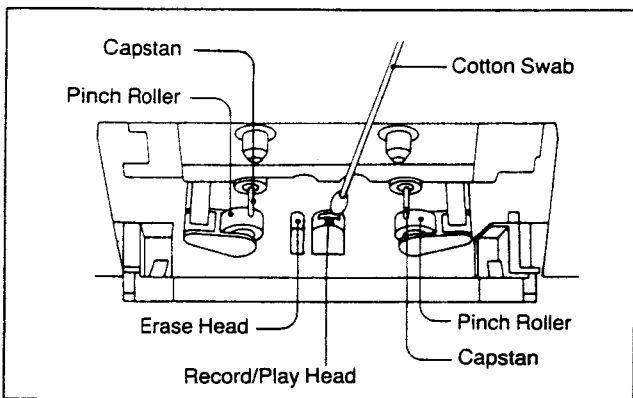

Head demagnetization

In order to maintain good sound quality during recording and playback, it is recommended that the heads should be demagnetized if distortion or poor sound quality persist after cleaning the heads.

If the heads become magnetized, they could create noise in recordings, loss of high-frequency response, or erasure of valuable recordings. Several types of head demagnetizers are available and may be purchased at local electronics supply stores. Follow the instructions that are supplied with the device.

- Do not bring any type of metal objects or tools such as magnetic screwdrivers in contact with the head assembly.

Maintenance of external surfaces

To clean this unit, use a soft, dry cloth.

For very dirty surfaces, dip a soft cloth in a weak soap-and-water solution and wring well. After cleaning, wipe with a soft, dry cloth. Never use alcohol, paint thinner, benzine, or a chemically treated cloth to clean this unit.

Such chemicals may damage the unit's finish.

ACCESSORIES

- Stereo connection cable 2
(SJP2249-3)
- AC plug adaptor..... 1
(SJP9215) For (GC) area only.

- AC power supply cord 1

RJA0004 (GC)
SFDAC05E03 (E, EG)
SJA173-1 (GN)
SJA193-1 (EB)

CONNECTIONS

Follow the figures below to connect the unit with other units. Make sure that the power has been turned off to the units while they are being connected.

1 Regular connections

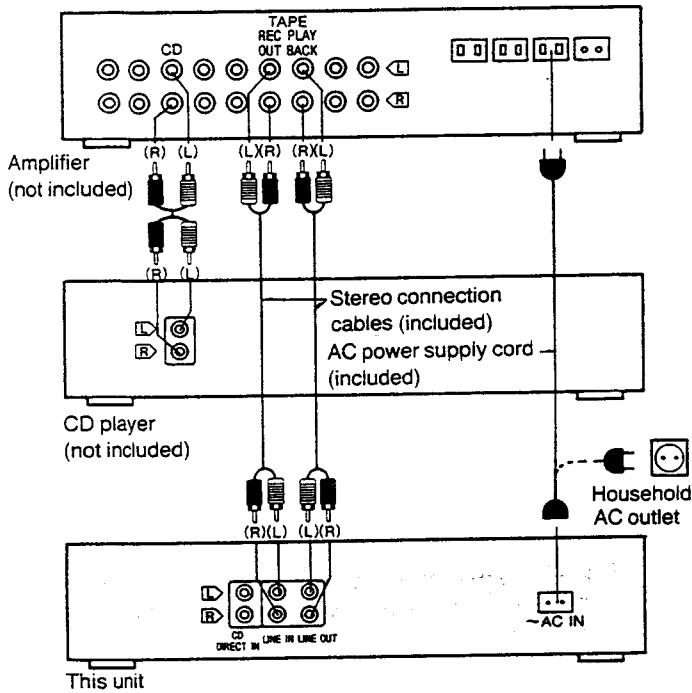

2 When there are 2 sets of CD player output terminals

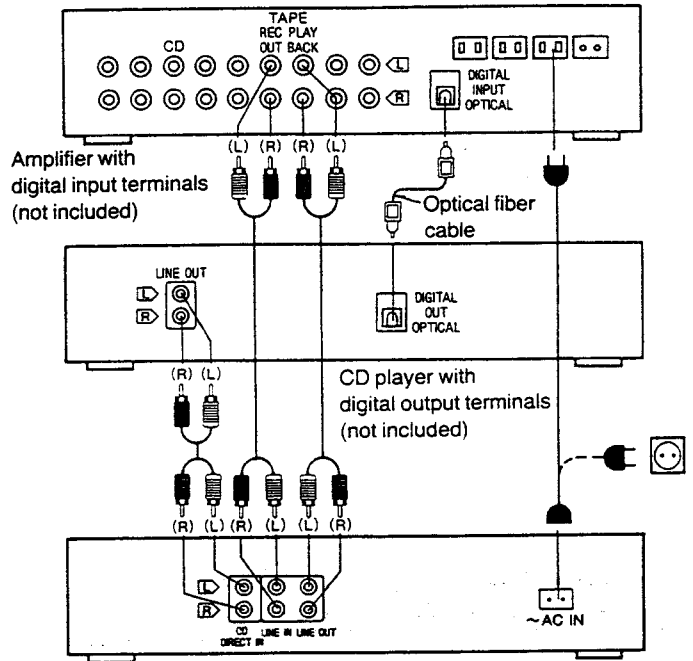

Note:

This connection diagram applies for a CD player equipped with digital output terminals. If the CD player is provided with 2 sets of analog output terminals, connect one set to the CD analog input terminals on the amplifier. These connections obviate the need to change any of the connections for CD direct recording.

Direct recording from CD player

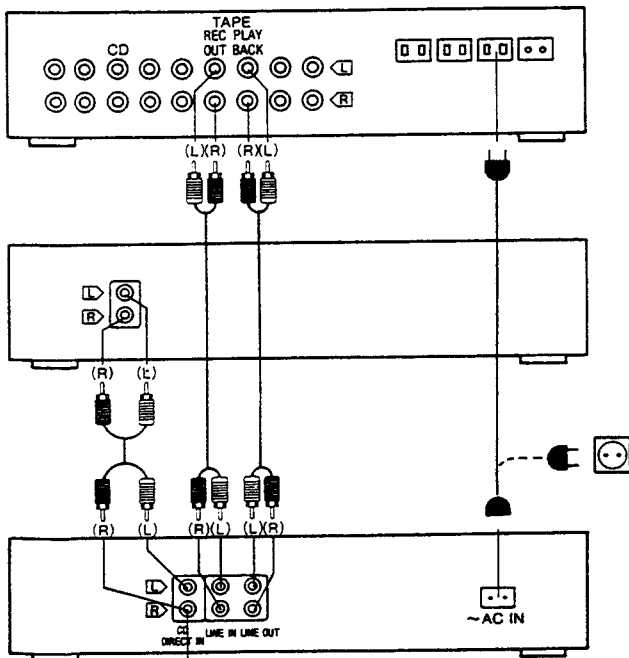

DC direct input terminals

CD direct recording

Direct connection between the CD player and CD direct input terminals on the stereo cassette deck enables the line output signals from the CD player to be connected by the shortest possible route without passing them through the amplifier. As a result, the high-range loss and cross talk can be improved.

In addition, the signal-to-noise ratio can also be enhanced since the input sensitivity of the CD direct input terminals is set in accordance with the output level of the CD player and is lower than the line input terminals.

Note:

The configuration of the AC outlet and AC power supply cord differs according to area.

For United Kingdom

Household AC outlet

Fit a suitable plug to the AC power supply cord.

Note: Return to the regular connections upon completion of the recording.

FRONT PANEL CONTROLS AND FUNCTIONS

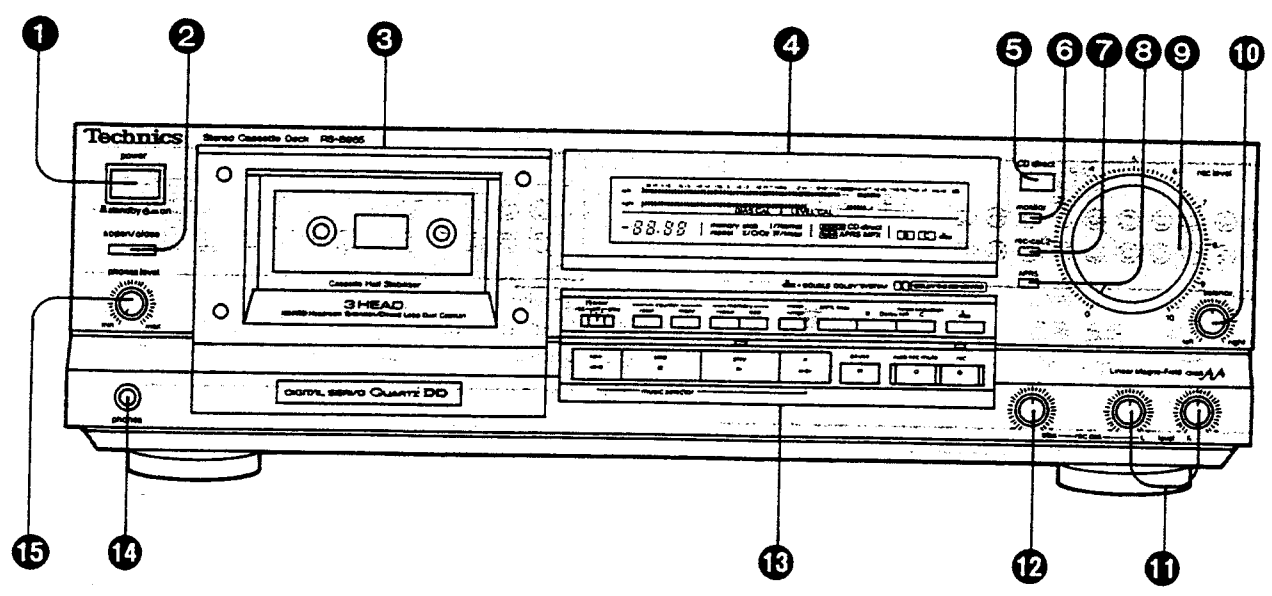

Control section I

- 1 Power "standby ⏻ /on" switch (power/ ⏻ standby ⏻ on)**
 This switch switches ON and OFF the secondary circuit power only. The unit is in the "standby" condition when this switch is set to the standby ⏻ position. Regardless of the switch setting, the primary circuit is always "live" as long as the power cord is connected to an electrical outlet.
- 2 Open/close button (⏏ open/close)**
 This button can be used to open or close the cassette holder.
- 3 Cassette holder**
- 4 Display section**
- 5 CD direct button (CD direct)**
 This button enables direct input for the signals from the CD player connected to this unit.
- 6 Monitor switch (monitor)**
 In order to monitor the tape (check the recording condition), the sound on the tape (immediately after recording) and the sound of the sound source (the original sound, before recording) can be alternately selected by pressing this button. (The corresponding indicator will illuminate.)
- 7 Calibration selector (rec cal.)**
 This selector can switch the input level display between the level adjustment indicator and bias adjustment indicator.
- 8 APRS button (APRS)**
 This button can be used to hold the peak level while monitoring the input sound. (Refer to page 6.)
- 9 Recording-level control (rec level)**
 This control can be used to regulate the recording level and the peak level.
- 10 Recording-balance control (balance)**
 This control can be used to balance the left and right sound levels during recording.
- 11 Calibration-level control (rec cal. level)**
 The sensitivity differences (high or low recording levels) for each tape type can be corrected by using these controls.
- 12 Calibration-bias control (rec cal. bias)**
 The frequency response for each tape type can be equalized by using this control.
- 13 Operation section**
- 14 Headphones jack (phones)**
- 15 Headphones volume control (phones level)**

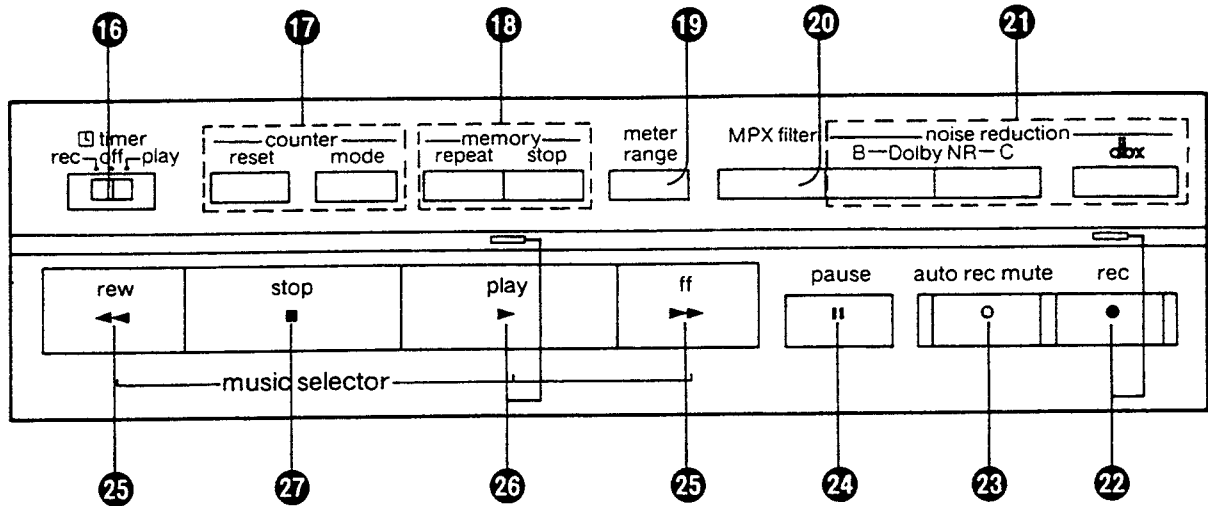

Control section II

- 16 Timer switch** (☐ timer)
This switch is used to automatically begin a tape recording or tape playback at a certain time, selected by a timer (not included).
- 17 Counter buttons** (counter reset/mode)
reset: This button can be used to reset the tape/linear counter indication to "000."/"00.00".
mode: This button can be used to select the tape/linear counter indication.
- 18 Memory-mode buttons** (memory repeat/stop)
repeat: This button can be used to set this unit to the "A-B repeat" mode.
stop: This button can be used to rewind the tape to the preset "0000" point when the rewind (◀◀) button is pressed.
- 19 Meter-range selector** (meter range)
This selector can be used to select the meter-range display of the input level meter.
- 20 Multiplex filter switch** (MPX filter)
This switch prevents the Dolby circuit from operating in error when FM stereo broadcasts are recorded using the noise reduction function.
- 21 Noise-reduction buttons** (noise reduction)
These buttons can be used to reduce the hiss noise that is characteristic of tape. This unit is provided with both the Dolby B NR-type and C NR-type, and dbx noise-reduction systems.
- 22 Record button and indicator** (rec/●)
This button can be used to begin recording on the tape deck.
- 23 Automatic-record-muting button** (auto rec mute/○)
This button can be used to make a silent interval on the tape being recorded on tape deck.
- 24 Pause button** (pause/||)
This button can be used to pause the tape deck.
- 25 Rewind/fast-forward/search buttons** (rew/◀◀, ff/▶▶)
These buttons can be used to fast forward or rewind the tape, or to easily search for the tune's beginning of the tape quickly.
- 26 Playback button and indicator** (play/▶)
This button can be used to start the playback or recording of the cassette.
(The tape will then begin moving in the left-to-right direction.)
When this indicator illuminates steadily, it indicates that this tape deck is in the playback mode or the recording mode. When it flashes continually, this is an indication that this tape deck is in the pause mode or the recording stand-by mode.
- 27 Stop button** (stop/■)
This button can be used to stop the tape deck.

RECORDING WITH HIGH TONE QUALITY

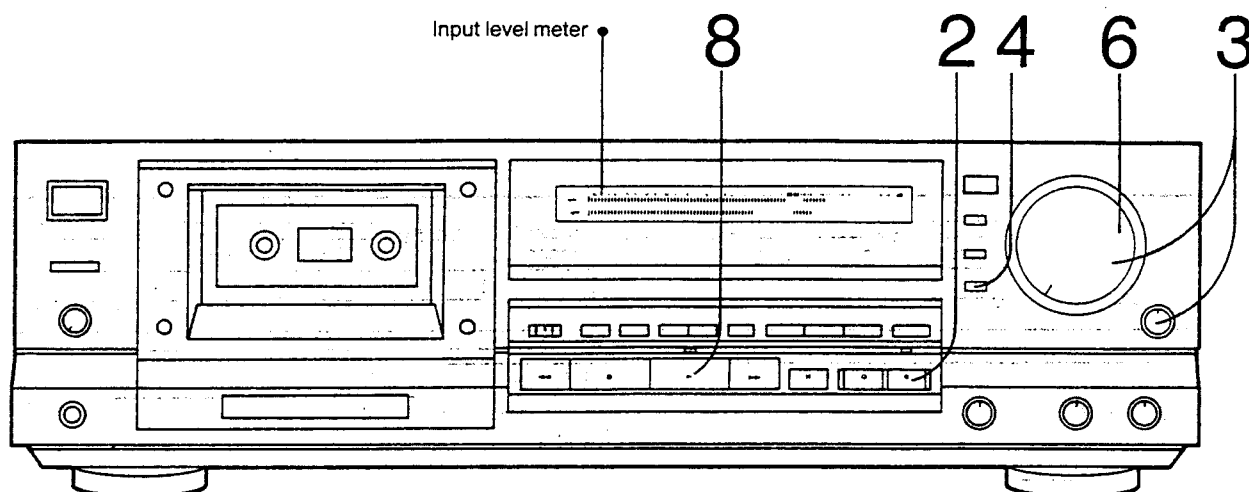

APRS function

Because the dynamic range of cassette tape is narrower than the dynamic range of a digital source, the recording will be too noisy if the recording level setting is too low, and, conversely, the recorded sound will be distorted if the setting is too high.

It was for this reason that it has always been recommended that the signals to be recorded be first (before recording) input to the cassette deck and the recording level then be set while watching the level meter, but, for former conventional level meter equipped with the peak-hold function, it was necessary to re-adjust and input the signals again if the level setting was too high or too low.

This unit, however, is equipped with the **APRS: Advanced Precise Recording-level System**, which holds and displays the maximum peak of the input signal level, so that once the peak level of the source is held, there is no necessity to re-input the source signals, and the optimum recording level can be set.

•The APRS function can be used only during the recording-standby mode.

1 Prepare for recording as described in steps 1 to 6.

1 Switch the amplifier ON, and select the input source.

2 Switch OFF the timer switch.

3 Switch ON the power "standby \odot /on" switch.

4 Press the open/close button to open the cassette holder, and then insert the cassette to be used for recording.

(The part of the cassette where the tape is exposed should face downward.)



Press the open/close button again to close the cassette holder.

5 Press the button corresponding to the noise-reduction system to be used.

(The noise-reduction indicator will illuminate.)
If no noise-reduction system is to be used, press the noise-reduction button corresponding to the noise-reduction indicator that is illuminated. (The indicator will then switch OFF.)

6 The sound source to be recorded should be played before the recording is started in order to adjust the recording level.

2 Press the record button.

(The recording indicator will illuminate and the playback indicator will flash continuously; the unit will be in the recording stand-by mode.)

3 Set the recording-level control and the recording-balance control to the suitable position for the sound source.

4 Press the APRS button.
(The APRS indicator will illuminate.)

5 Play the sound source to be recorded, from beginning to end.

[The peak level (the highest level of the input signal) of the sound source will be displayed and held on the input-level meter.]

Input level meter

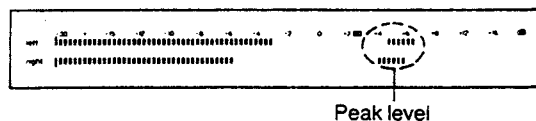

Peak level

Note:

The range within which the peak level can be held is -8 dB to $+16$ dB. Note that the APRS indicator will flash continuously if the peak level of the sound source is input at a level that exceeds the maximum recording level ($+16$ dB).

If that happens, press the APRS button to cancel the APRS function, and then reset the recording level and set the APRS once again.

6 Using the recording-level control, adjust the peak level to the desired setting.

The peak level will move to the right when the recording-level control is turned to the right, and will move to the left when the recording-level control is turned to the left.

•The recording-balance control cannot be used to adjust the peak level.

7 Begin playing the sound source from the beginning once again.

8 Press the playback button.

(The playback indicator will illuminate steadily, and the recording will begin.)

The APRS indicator will switch OFF, and the indication of the input-level meter will return to the ordinary peak-hold mode.

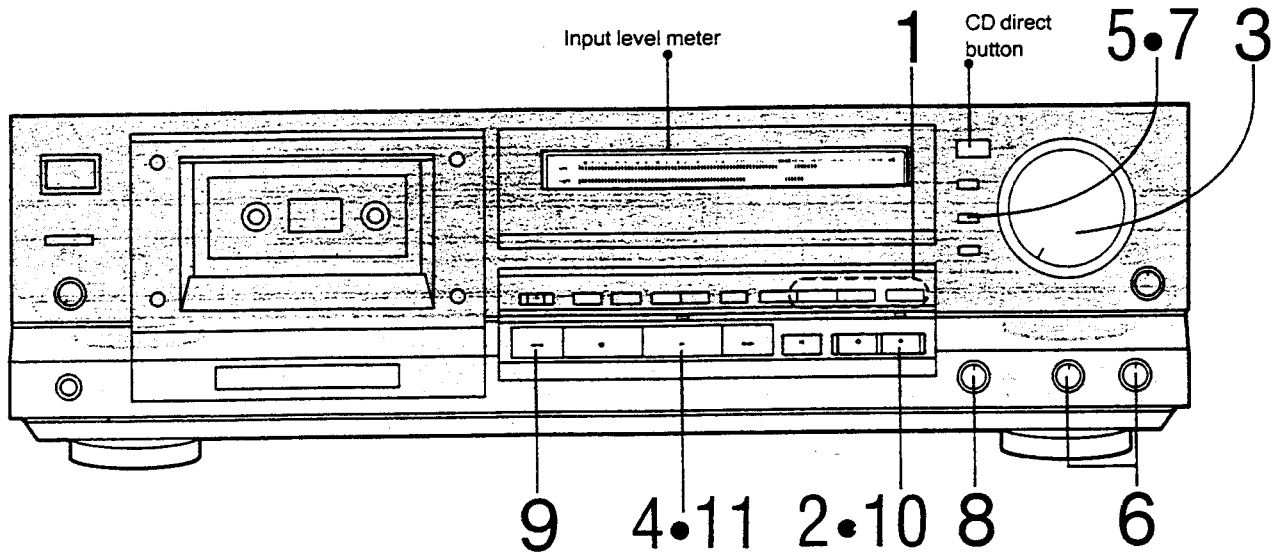

Recording calibration

Depending on the type of tape and the brand used, cassette tapes are characterized by individual variations in sensitivity differences (high and low recording levels) and frequency responses (particularly in the high range). In addition, the recording and playback levels differ when recording is done using a noise reduction system so that the sound quality is sometimes impaired.

To deal with these problems, this unit comes with a calibration function which takes the form of bias adjustment and is based on a test oscillator. The tape's performance can therefore be given full rein by setting the optimum bias value and compensating for the sensitivity in accordance with the recording characteristics of the tape while observing the input level display.

■ Before proceeding with calibration

*Switch to the CD direct mode when recording directly from the CD player.

1 Press the button corresponding to the noise-reduction system to be used.

(The noise-reduction indicator will illuminate.)

If no noise-reduction system is to be used, press the noise-reduction button corresponding to the noise-reduction indicator that is illuminated. (The indicator will then switch OFF.)

2 Press the record button.

(The recording indicator will illuminate and the playback indicator will flash continuously; the unit will be in the recording stand-by mode.)

3 The sound source to be recorded should be played before the recording is started in order to adjust the recording level.

4 Press the playback button.

(The playback indicator will illuminate steadily, and the recording will begin.)

■ Calibration procedure

5 Press the calibration selector.

[The input level display switches to the level adjustment indicator. (in figure ① on next page)]

6 Compensate for the difference in the recording levels using the calibration-level control.

Adjust the left and right recording levels to the indicator arrow position. (in figure ② on next page)

7 Press the calibration selector again.

The level adjustment indicator now switches to the bias adjustment indicator. (in figure ③ on next page)

8 Compensate for the difference in the high-range sound quality using the calibration-bias control.

[Adjust the high-range recording level to the low-range recording level. (in figure ④ on next page)]

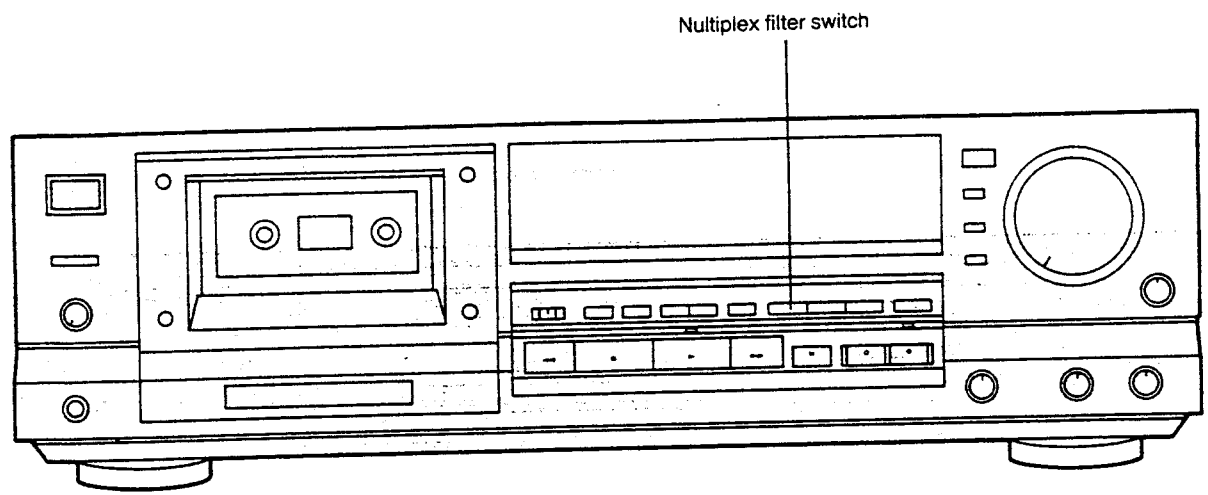

Level adjustment indicator

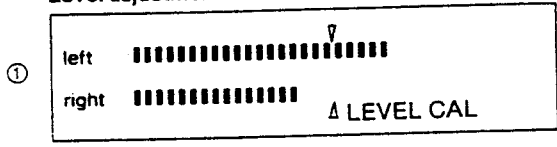

Adjust the left and right recording levels to the arrow position.

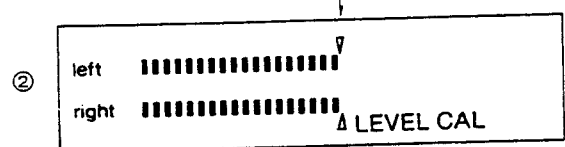

Bias adjustment indicator

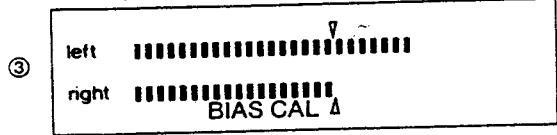

Adjust the high-range recording level to the low-range recording level.

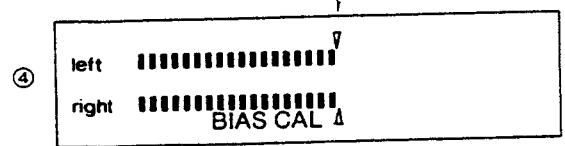

(The "left" side indicates the recording level of the high frequencies; the "right" side indicates the recording level of the low frequencies.)

Starting the recording

- 9 Return to the original play source, and press the rewind button to rewind the tape.
- 10 Press the record button.
(The recording indicator will illuminate and the playback indicator will flash continuously; the unit will be in the recording stand-by mode.)
- 11 Press the playback button to start the recording, and start playing the source which is to be recorded.

MXP filter

Because the pilot signals*, etc. included with FM stereo broadcast signals are subjected to Dolby noise-reduction processing in the same way as the music signals when an FM stereo broadcast is being recorded, there is apt to be deterioration of the tone quality, and the noise-reduction effect is reduced.

This unit, however, is provided with an MPX filter that filters out the 19 kHz frequency, which is the frequency of the pilot signal. Note that there is virtually no audible effect upon the tone quality as a result of the use of the MPX filter.

This switch can be used during the recording of an FM stereo broadcast that employs Dolby noise reduction so as to prevent misoperation of the Dolby noise reduction. This switch, however, should be switched OFF when a sound source other than the FM broadcast is being recorded, such as for example, a sound source that has a wide frequency range, such as a compact disc, etc.

***Pilot signal**

The pilot signal is a signal that is used to separate FM broadcast signals in stereo (left and right channels); this signal is generated on a frequency that is very close to the 19 kHz music band.

Monitor Switch

This unit is of 3-head type, and the record head is independent of the playback head. Also, the sound before recording can be compared with the recorded sound by use of the monitor switch, therefore the state of recording can be easily checked.

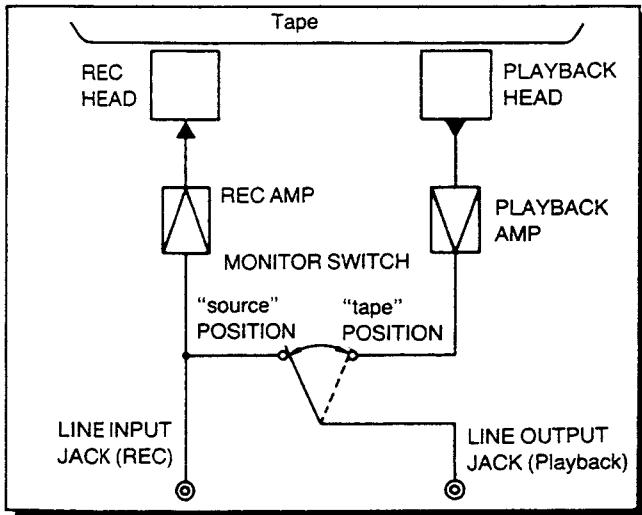

Linear Magne-Field class AA

The recording-equalizer amplifier is an amplifier for supplying (to the head) the current necessary for recording. Usually, loads such as the recording head and bias trap circuitry (circuitry for control of the bias current) would be applied to the output of this amplifier, with the result that complex changes of the current phase occur, causing distortion of the recording signal.

The recording-equalizer amplifier used in this unit, however, is a linear magne-field class AA amplifier that is a combination of class A voltage-control amplifier circuitry and current-drive amplifier circuitry. (See the figure below.) As a result, a current flow that is equivalent to the current flowing in the pure resistance of the current-drive amplifier can be supplied to the recording head. Consequently, a magnetic field that corresponds to the input signals is produced at the head and is recorded on the tape, which means that recorded sounds are faithful to the original sound source, without fluctuations of the current phase.

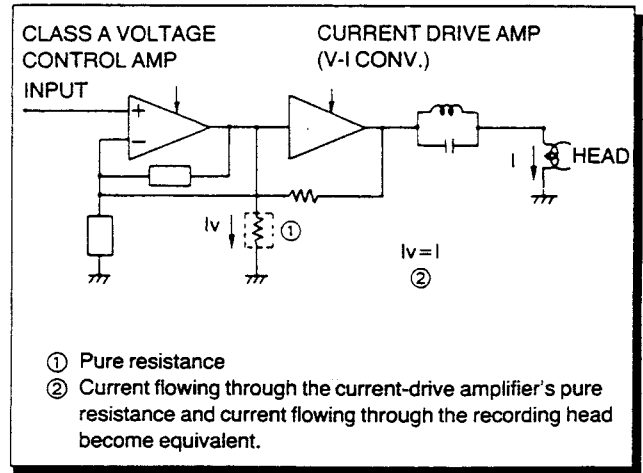

DISASSEMBLY INSTRUCTIONS

"ATTENTION SERVICER"

Some chassis components may have sharp edges. Be careful when disassembling and servicing.

Ref. No. 1	Removal of the cabinet
Procedure 1	• Remove the 6 screws (①~⑥).

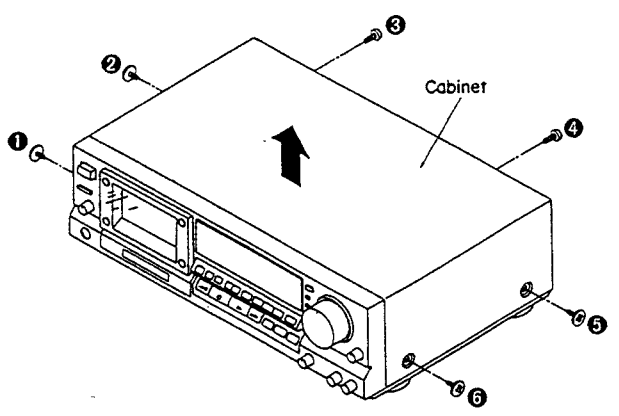

Ref. No. 2	Removal of the angle (A), (B)
---------------	--------------------------------------

Procedure 1→2	
------------------	--

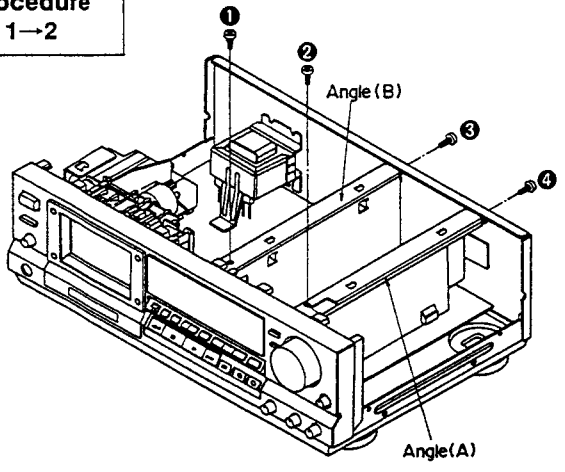

• Remove the 4 screws (①~④).

Ref. No. 3	Removal of the rec amp P.C.B. and dbx/Dolby NR P.C.B.
---------------	--

Procedure 1→2→3	
--------------------	--

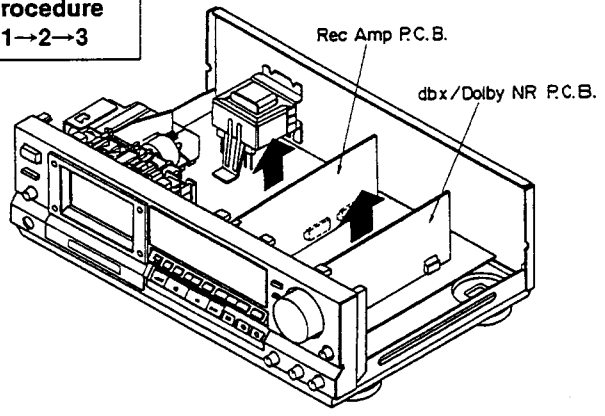

1. Remove the rec amp P.C.B. in the direction of the arrow.
2. Remove the dbx/Dolby NR P.C.B. in the direction of the arrow.

Ref. No. 4	Removal of the front panel
---------------	-----------------------------------

Procedure 1→2→4	
--------------------	--

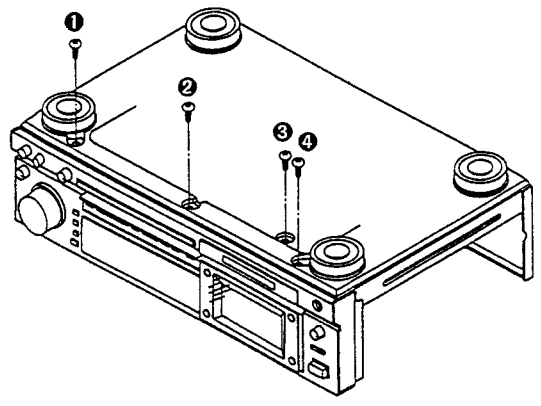

1. Remove the 6 screws (①~⑥).

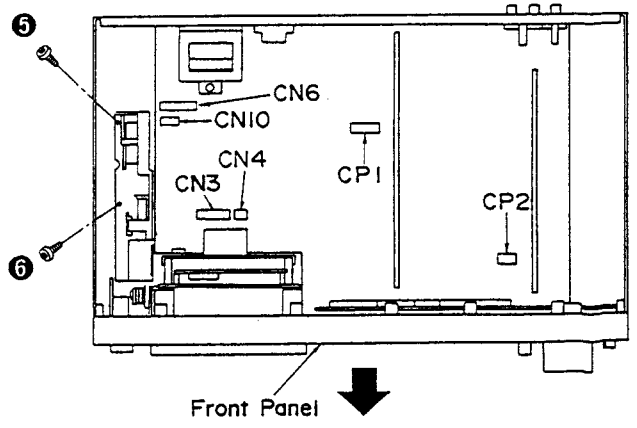

2. Remove the 2 connectors (CP1, CP2).
3. Remove the 4 flat cables (CN3, CN4, CN6, CN10).
4. Remove the front panel in the direction of the arrow.

Ref. No. 5 **Removal of the main P.C.B.**

Procedure
1→2→3→5

1. Remove the 8 screws (①~⑧).
2. Remove the rear panel from the projection of the bottom chassis.

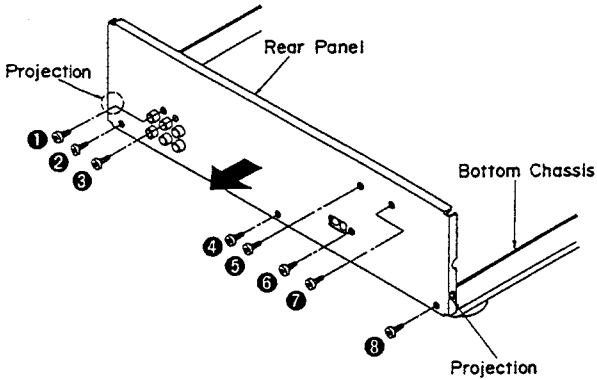

How to remove the flat cable

- Pull out the flat cable while pressing the connector.
1. Lift the connector.
 2. Pull out the flat cable.

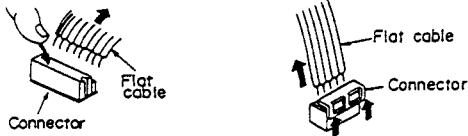

How to check the main P.C.B.

- When checking the soldered surfaces of main P.C.B. and replacing the parts, do as show.
1. Remove the 10 screws (②, ④, ⑧~⑮) in above figure.
 2. Remove the 6 screws (⑯~㉑).
 3. Remove the front panel in the direction of the arrow A.

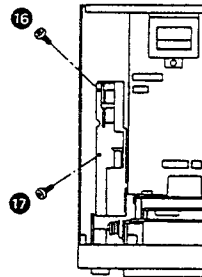

3. Remove the 7 screws (⑨~⑮).
4. Remove the 2 connectors (CP1, CP2).
5. Remove the 4 flat cables (CN3, CN4, CN6, CN10).
6. Remove the main P.C.B. in the direction of the arrow.

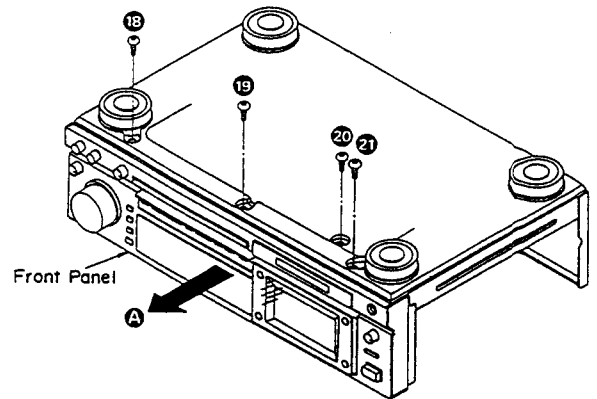
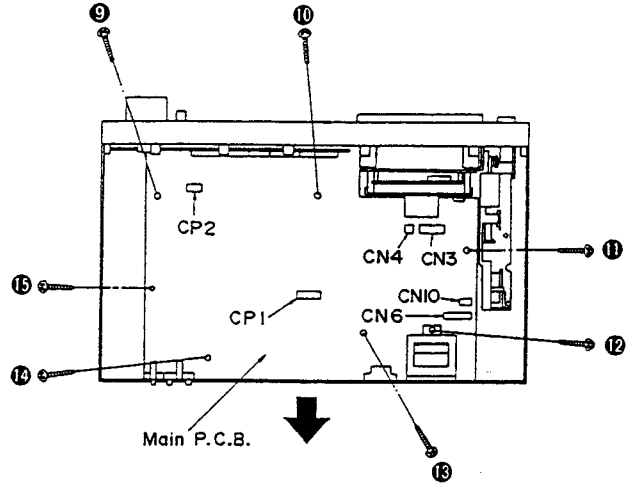

Ref. No. 6 **Removal of the mechanism unit**

Procedure
1→4→6

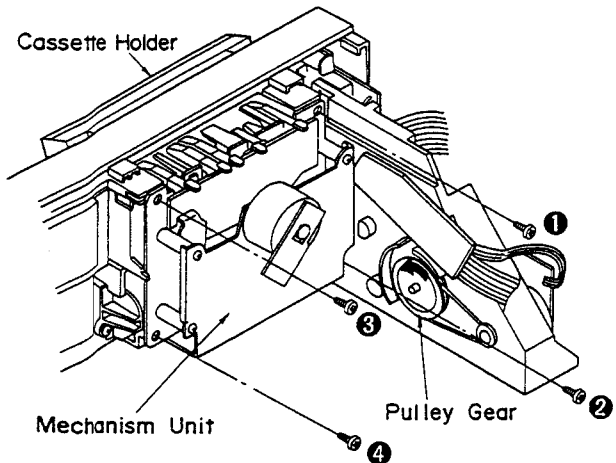

1. Turn the pulley gear in the direction of the arrow, and open the cassette holder.
2. Remove the 4 screws (①~④).

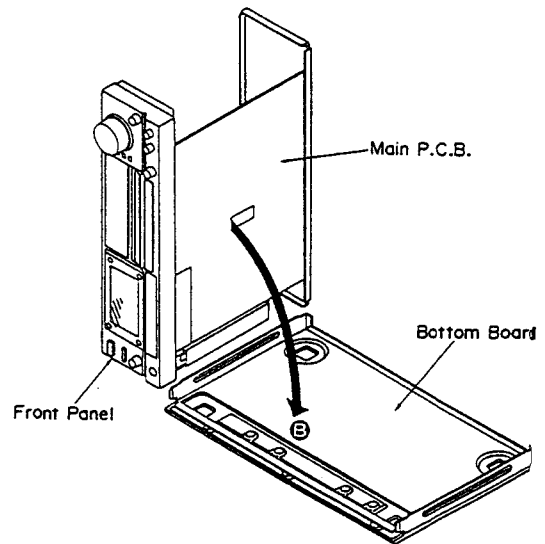

4. Remove the bottom board in the direction of the arrow B.
5. Reinstall the front panel to the main P.C.B.

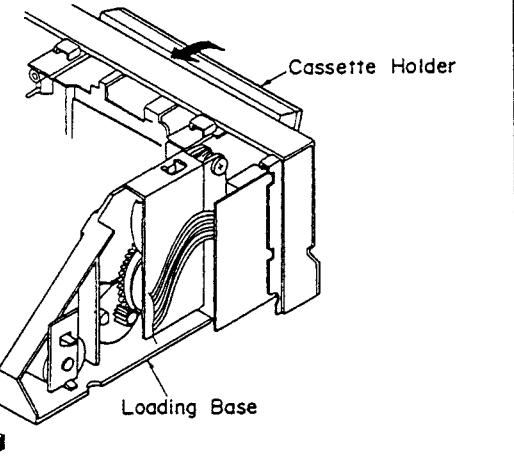
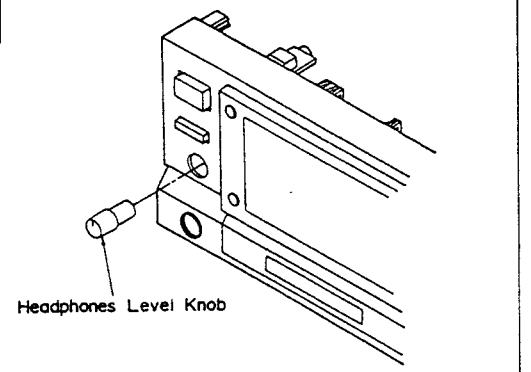
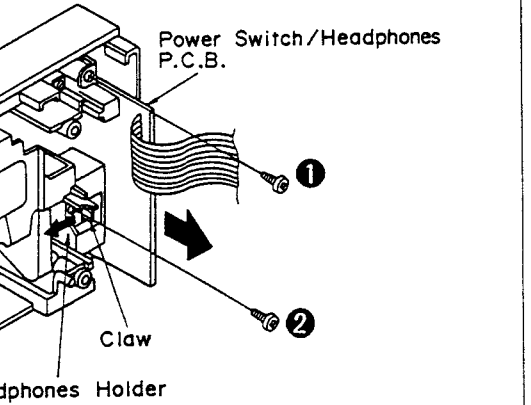
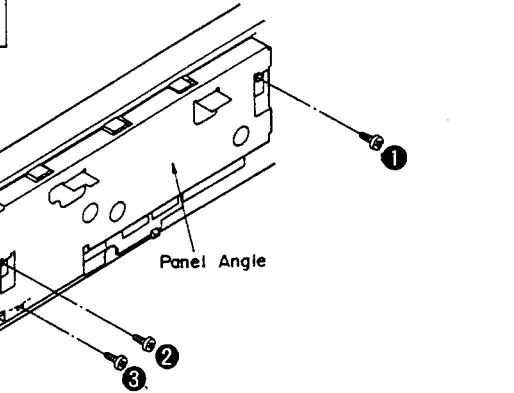
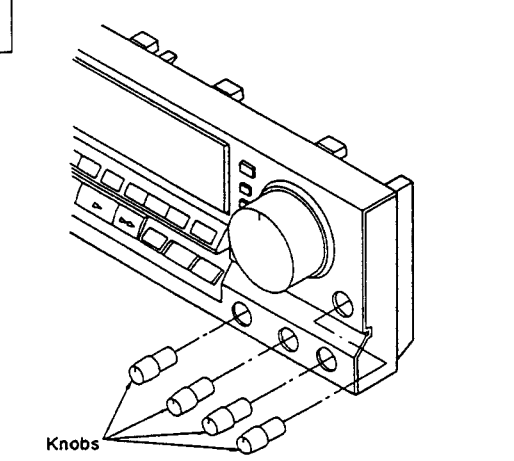
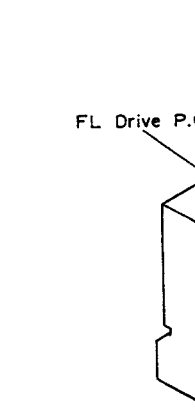
<p>Ref. No. 7</p>	<p>Removal of the loading base</p>	<p>Ref. No. 8</p>	<p>Removal of the power switch/headphones P.C.B.</p>
<p>Procedure 1→4→6→7</p>	 <p>1. Close the cassette holder. 2. Remove the loading base in the direction of the arrow.</p>	<p>Procedure 1→4→6→7→8</p>	 <p>1. Pull out the headphones level knob.</p>
<p>Ref. No. 9</p>	<p>Removal of the panel angle</p>	<p>Procedure 1→4→6→7→8</p>	 <p>2. Remove the 2 screws (①, ②). 3. Release the 1 claw. 4. Remove the headphones holder. 5. Remove the power switch/headphones P.C.B. in the direction of the arrow.</p>
<p>Procedure 1→4→9</p>	 <p>• Remove the 3 screws (①~③).</p>	<p>Ref. No. 10</p>	<p>Removal of the FL Drive P.C.B.</p>
<p>Procedure 1→4→9→10</p>	 <p>1. Pull out the 4 knobs.</p>	 <p>2. Remove the 3 screws (①~③). 3. Release the 2 claws. 4. Remove the FL P.C.B. in the direction of the arrow.</p>	

Ref. No. 11 **Removal of the rec level P.C.B.**

Procedure
10→11

1. Pull out the rec level knob.
2. Remove the 1 nut.
3. Remove the rec level P.C.B. in the direction of the arrow.

Ref. No. 12 **Removal of the operation switch P.C.B.**

Procedure
10→12

1. Remove the 4 screws (①~④).
2. Release the 4 claws.

Ref. No. 13 **Removal of the switch P.C.B.**

Procedure
10→12→13

1. Remove the switch P.C.B. in the direction of the arrow.
2. Release the 2 claws.

Ref. No. 14 **Removal of the cassette holder**

Procedure
1→4→6→7→14

1. Remove the 1 screw (①).
2. Remove the damper gear.
3. Remove the rib in the direction of the arrow A.

Ref. No. 15 **Removal of the cassette lid and cassette half stabilizer**

Procedure
14→15

1. Remove the cassette lid in the direction of the arrow.
2. Release the 2 claws.

Ref. No. 15 **Removal of the cassette lid and cassette half stabilizer**

Procedure
14→15

4. Remove the cassette holder in the direction of the arrow B.

Ref. No. 16	Removal of the open/close lever and open/close button
Procedure 8→16	
<p>• Release the 1 claw.</p>	

Ref. No. 18	Removal of the drive sector lever and loading angle
Procedure 7→18	
<ol style="list-style-type: none"> 1. Remove the 2 screws (①, ②). 2. Remove the angle. 	

Ref. No. 19	Removal of the drive gear
Procedure 7→18→19	
<ol style="list-style-type: none"> 1. Release the 2 claws. 2. Remove the drive gear in the direction of the arrow A. 	

Ref. No. 17	Removal of the leaf switch P.C.B. and eject drive motor
Procedure 7→17	
<p>■ Removal of the leaf switch P.C.B.</p> <ol style="list-style-type: none"> 1. Remove the 1 screw (①). 2. Release the 1 claw. 	
<p>■ Removal of the eject drive motor</p> <ol style="list-style-type: none"> 1. Remove the belt. 2. Remove the 2 screws (②, ③). 3. Release the 2 claws. 	

Ref. No. 19	Removal of the drive gear
Procedure 7→18→19	
<ol style="list-style-type: none"> 1. Release the 2 claws. 2. Remove the drive gear in the direction of the arrow A. 	

REPLACEMENT PARTS LIST

Notes : * Important safety notice.
 Components identified by Δ mark have special characteristics important for safety. When replacing any of these components use only manufacturer's specified parts.
 * Bracketed indications in Ref. No. columns specify the area. (Refer to the first page for area.)
 Parts without these indications can be used for all areas.
 * Remote Control Ass'y:
 Supply period for three years from termination of production.

Ref. No.	Part No.	Description	Ref. No.	Part No.	Description
INTEGRATED CIRCUITS					
IC201 (E, EK, EF, EH) (EB, E1, XL) (XA, XB)	AN6552F	I.C. PHONO EQ	VR300 VR304	EWCS6A020C15 EWCS6A020C15	VR. TONE VR VR. TONE VR
COILS AND TRANSFORMERS					
IC201 (EG)	AN6558F	I.C. PHONO EQ	L1 (EG)	SLQZ650M-H49	CHOKE COIL
IC301 (E, EK, EF, EH) (EB, E1, XL) (XA, XB)	M5218L	I.C. TONE AMP	L401 L402	SLQY07G-40 SLQY07G-40	CHOKE COIL CHOKE COIL
IC301 (EG)	M5220L	I.C. TONE AMP	T1 Δ (E, EG, EF, EH) (EB, E1)	SLT5M479-W1	POWER TRANSFORMER
IC401	SV13102A	I.C. POWER AMP	T1 Δ (EK, XL) (XA, XB)	SLT5M479-W1 SLT5M480-W1	POWER TRANSFORMER POWER TRANSFORMER
TRANSISTORS					
	2SK381DTA	TRANSISTOR	FUSES		
	2SC3112	TRANSISTOR	F1 Δ (EK, XL, XA) (XB)	XBA2C08TB0	FUSES 250V, T0.8A
DIODES					
D601	LN846RP-C	L.E.D	F1 Δ (E, EG, EF, EH) (EB, E1)	XBA2C10TB0	FUSE 250V, T1A
D602	LN446YP	L.E.D	F1 Δ (XA, XB)	XBA2C16TB0	FUSE 250V, A1.6A
D701 Δ	SVD1SR3S200A	RECTIFIER	SWITCHES		
D901	SVDS2V20	RECTIFIER	S1 Δ (XA, XB)	ESB8248V	SW. POWER SW
D902	SVDS2V20	RECTIFIER	S1 Δ (E, EG, EK, EF) (EB, E1, XL) (XA, XB)	ESB8249V	SW. POWER SW
D903	SVDS2V20	RECTIFIER	S2 Δ (XA, XB)	ESE37263	SW. VOLTAGE SELECTOR
D904	SVDS2V20	RECTIFIER	S3	SSH578	SW. INPUT SELECTOR
D905	MA4068M	DIODE	S4	SSH1193	SW. SPEAKER IMPEDANCE
D906	MA4068M	DIODE	S5	SSH2122	SW. SPEAKER SW
D907	MA4075M	DIODE			
D908	MA4075M	DIODE			
LED	LN041330P	DIODE, GAASP			
VARIABLE RESISTORS					
VR301	EWCXUAF20B15	VR. MAIN VR			
VR302	EWHF5AF20G15	VR. BALANCE			

Ref. No.	Part No.	Description	Ref. No.	Part No.	Description
CABINET AND CHASSIS					
1	SBN1032-4	KNOB	29	SJF3062-1N	TERMINAL BOARD
1	SBN1032-2	KNOB	30	SGP7291-1A	REAR PANEL
2	SBC839E	BUTTON	(XA)		
2	SBC839-1E	BUTTON	30	SGP7291A	REAR PANEL
3	SGX9025	ORNAMENT	(E, EF, EH, EB) (E1)		
3	SGX9025-1	ORNAMENT	30	SGP7291B	REAR PANEL
4	SBC839C	BUTTON	(EK)		
4	SBC839-1C	BUTTON	30	SGP7291C	REAR PANEL
5	SBC839B	BUTTON	(EG)		
5	SBC839-1B	BUTTON	30	SGP7291D	REAR PANEL
6	SBC839A	BUTTON	(XL)		
6	SBC839-1A	BUTTON	30	SGP7291-2A	REAR PANEL
7	SBC840A	BUTTON	(XB)		
7	SBC840-1A	BUTTON	31	SJS9330A	OUTLET COVER
8	SBN1208	KNOB	(XA)		
8	SBN1111	KNOB	32	SJS9231A	AC INLET COVER
13	SBC315-7	BUTTON	(E, EG, EK, EF) (EH, EB, E1) (XA, XB)		
13	SBC315-4T	BUTTON	32	SJS9234A	AC INLET COVER
14	SJJ134B	JACK	(XL)		
15	SBC666-5	BUTTON	36	SJT30640LX-V	CONNECTOR
15	SBC666	BUTTON, POWER	36	SJT30740LX-V	CONNECTOR
16	SUB275	ROD	37	SKL293	FOOT
17	SKC1880K993	CABINET BODY	37-1	SKL293	FOOT
17	SKC1880K993	CABINET BODY	38	SXE1134	HEAT SINK
19	SJS305-1	JACK	39	SGWU600-KE	FRONT PANEL
(E, EG, EK, EF) (EH, EB, E1) (XL)			39	SGWU600-SE	FRONT PANEL
20	SJT388	FUSE HOLDER	39-1	SMC6424-1	SHIELD COVER
22 Δ	SJS9231-1B	AC INLET	41	SMX943	RECTIFIER
(E, EG, EK, EF) (EH, EB, E1) (XL)			42	SMC1195-4	SHIELD COVER
22 Δ	SJS9231-1B	AC INLET	N1	SNE4021	NUT
(XA, XB)			N2	XTB3+8G	SCREW
22 Δ	SJS9234B	AC INLET	N3	XTW3+8T	SCREW
(XL)			N4	SNE2129-3	SCREW
23 Δ	SJS9232B	AC, OUTLET	N4	SNE2129-2	ORNAMENT SCREW
(XA)			N5	XTBS3+8JFZ1	SCREW
24	SHW25K150-1	WASHER	N6	XTB3+6FFZ	SCREW
(XA, XB)			N7	SNE2126	ORNAMENT SCREW
25	SJF4818-1	TERMINAL BOARD	N8	XTB3+16J	SCREW
26	SBC165	BUTTON, IMPEDANCE	N9	SNE2095-5	NUT
27	SUD472	SPACER	(XA, XB)		
			N9	XTBS3+8JFZ1	SCREW
			N10	XSN3+6S	SCREW

Ref. No.	Part No.	Description	Ref. No.	Part No.	Description
PACKING MATERIAL					
P1	SPG6188	PACKING CASE	(EK)		
(EF)			A2 Δ	SJA173	POWER CORD
P1	SPG6187	CARTON BOX	(XL)		
(E, EG, EK, EH) (EB, E1, XL) (XA, XB)			A2 Δ	SJA183	POWER CORD
P1	SPG6188	PACKING CASE	(XB)		
(E, EG, EK, EH) (EB, E1, XL) (XA)			A2 Δ	SJA185	POWER CORD
P2	SPS5104	PAD	(XA)		
P3	SPS5105	PAD	A4	SQF13134	INSTRUCTION BOOK
P4	SPS5106	PAD	(E, EH, EB)		
P5	SPP719	PROTECTION COVER	A4	SQF13135	INSTRUCTION BOOK
ACCESSORIES					
A2 Δ	SFDAC05E03	POWER CORD	(EG)		
(E, EG, EF, EH) (EB, E1)			A4	SQF13136	INSTRUCTION BOOK
A2 Δ	SFDAC05G02	POWER CORD	(EK)		
			A4	SQF13137	INSTRUCTION BOOK
			(XA)		
			A4	SQF13165	INSTRUCTION BOOK
			(EF, XL)		
			A4	SQF13166	INSTRUCTION BOOK
			(E1)		
			A4	SQF13138	INSTRUCTION BOOK
			(XB)		
			A5 Δ	RJP120ZBS-H	AC PLUG ADAPTOR
			(XA, XB)		

• IC551 (HD404302SA07): MICROCOMPUTER (This microcomputer is used for FL meter operation.)

Pin No.	Mark	I/O Division	Function	Pin No.	Mark	I/O Division	Function
1	S5	O	Segment signal for FL display	22	AVcc	—	Power supply terminal
2	S6	O		23	VR IN	I	Rec level control (VR MAX...+5V)
3	S7	O		24	F IN	I	Function key terminal (COUNTER RESET/COUNTER MODE/APRS)
4	Vdisp	—	Pull down power supply terminal (-Vcc)	25	SIG L	I	LCH level signal
5	S8	O	Segment signal for FL display	26	SIG R	I	RCH level signal
6	S9	O		27	AVss	—	Connected to GND
7	S10	O		28	RESET	I	Reset terminal (with Reset: "H")
8	S11	O		29	TEST	I	Test terminal
9	S12	O		30	OSC 1	O	Clock OSC terminal (4MHz)
10	S13	O		31	OSC 2	I	
11	S14	O		32	Vcc	I	Power supply terminal
12	S15	O		33	G1	O	Grid signal for FL display
13	S16	O		34	G2	O	
14	S17	O		35	G3	O	
15	S18	O	36	G4	O		
16	S19	O	37	G5	O		
17	RPT	I	Reel pulse signal of tape up reel	38	G6	O	Segment signal for FL display
18	RPS	I	Reel pulse signal of supply reel	39	S1	O	
19	MP	O	Memory pulse signal ("L" for 50ms. with counter "0000")	40	S2	O	
20	DISP	I	Serial data signal (ACTIVE: "H")	41	S3	O	
21	GND	—	GND terminal	42	S4	O	



■ TERMINAL FUNCTION OF IC'S

• IC901 (MB88511-250N): MICROCOMPUTER (This microcomputer is used for mechanical operation.)

Pin No.	Mark	I/O Division	Function
1	DMT	O	Line out mute signal ("H"...ON, "L"...OFF)
2	RMT	O	REC AMP mute signal ("H"...ON, "L"...OFF)
3	BOS	O	BIAS OSC ON/OFF control signal ("H"...OFF, "L"...ON)
4	REC	O	REC LED ON/OFF control signal ("H"...OFF, "L"...ON)
5	PLAY	O	PLAY LED ON/OFF control signal ("H"...OFF, "L"...ON)
6	EJECT F	O	Power eject motor open control signal ("H"...OPEN, "L"...CLOSE/STOP)
7	EJECT R	O	Power eject motor close control signal ("H"...CLOSE, "L"...OPEN/STOP)
8	CAPM	O	Capstan motor ON/OFF control signal ("H"...OFF (POWER OFF or ABNORMAL CONDITION), "L"...ON)
9	SOL1	O	Trigger solenoid ON/OFF control signal ("H"...OFF, "L"...ON)
10	SOL2	O	Brake solenoid ON/OFF control signal ("H"...OFF, "L"...ON)
11	SOL2C	O	Brake solenoid hold ON/OFF control signal ("H"...OFF, "L"...ON (FF/REW/MS))
12	RP (REEL PULSE)	I	Reel pulse signal
13	RMR	O	Reel motor reverse control signal ("H"...REW, "L"...STOP/PLAY/FF)
14	RMF	O	Reel motor forward control signal ("H"...FF/PLAY, "L"...STOP/REW)
15	OSC	I	Single capstan/Dual capstan select signal ("H"...DUAL CAPSTAN, "L"...SINGLE CAPSTAN)
		O	Calibration OSC circuit ON/OFF control signal ("H"...OFF, "L"...ON)
16	Ex	I	Clock OSC terminal (6MHz)
17	X	O	
18	RES	I	Reset signal ("L"...RESET)
19	OSCF	O	Not used in this unit. Calibration OSC circuit (400Hz/10kHz) select signal ("H"...HIGH FREQ. (10kHz), "L"...LOW FREQ. (400Hz))
20	POF	I	AC POWER detect signal
21	Vss	-	GND

Pin No.	Mark	I/O Division	Function											
22	DIRECT	I	CD direct operation det. signal											
		O	CD direct/LINE input select control signal ("H"...CD DIRECT, "L"...LINE INPUT)											
23	C	O	Dolby NR mode select signal											
24	B			<table border="1"> <tr> <td>NR OFF</td> <td>Dolby B</td> <td>Dolby C</td> <td>dbx</td> </tr> <tr> <td>C</td> <td>H</td> <td>H</td> <td>L</td> </tr> <tr> <td>B</td> <td>H</td> <td>L</td> <td>H</td> </tr> </table>	NR OFF	Dolby B	Dolby C	dbx	C	H	H	L	B	H
NR OFF	Dolby B	Dolby C	dbx											
C	H	H	L											
B	H	L	H											
25	MPX	O	MPX coil ON/OFF control signal ("H"...MPX OFF, "L"...MPX ON)											
26	T/S	I	Two head/Three head select signal ("H"...THREE HEAD)											
		O	Tape/Source monitor select control ("H"...TAPE MONITOR, "L"...SOURCE MONITOR)											
27	HALF	I	Cassette half det. SW terminal ("L"...ON)											
28	MODE	I	Mechanism mode SW terminal											
29	ARM	I	Auto Rec Mute key signal ("L"...PUSH)											
30	AVss	-	Connected to GND											
31	AVR	-	Connected to GND											
32	AVcc	-	Power supply terminal											
33	KEY 1	I	Key SW input (STOP/FF REW/PLAY/REC/PAUSE/C/B/MPX/TIMER REC/TIMER PLAY)											
34	KEY 2	I	Key SW input (MEMORY REPEAT/MEMORY STOP/EJECT/MONITOR/CD DIRECT/OSC/TEST)											
35	ATS	I	Auto Tape Select SW input (ATSC/ATSM/EJECT OPEN LEAF SW)											
36	INH	I	REC INH SW Input (REC INH/EJECT MOTOR LEAF SW)											
37	SYNC	-	Connected to GND											
38	DISP	O	Serial data signal of FL display (ACTIVE: "H")											
39	MSP	I	Music select det. signal ("H"...NO SIGNAL, "L"...ON SIGNAL)											
40	MEMORY PULSE	I	Memory Pulse signal											
41	REMOCON	I	Not used in this unit. Remote control serial data ("L" for 50ms. with counter "0000")											
42	Vcc	-	Power supply terminal											

REC CAL. ADJUSTMENT

1. After the overall frequency characteristics and over all gain are adjusted, insert the test tape (QZZCRA) in the unit and then set the recording mode (REC/PLAY).

– Level Adjustment –

- 2. First, press the REC CAL button. (The indication “LEVEL CAL” will appear in the FL meter.)
- 3. Adjust VR9 so that the level of the right and left channels reach the Δ mark as shown.

– Bias Adjustment –

- 4. Next, press the REC CAL button again. (“BIAS CAL” will be displayed in the FL meter.)
- 5. Adjust VR10 so that the indication of the left channel level reaches the Δ mark as shown.

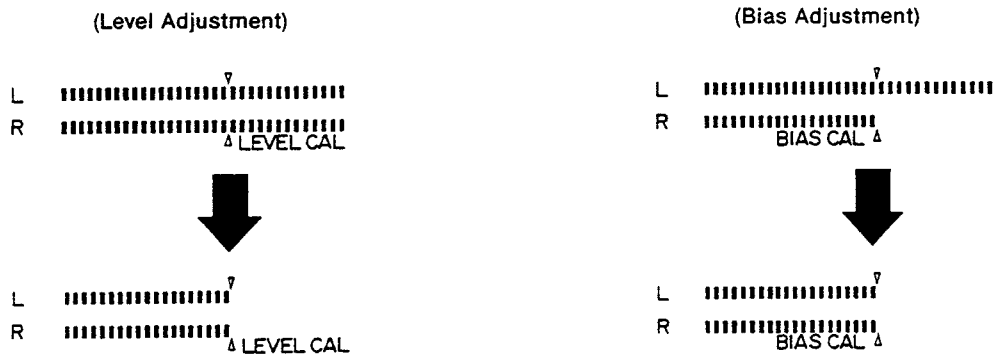

Fig. 19

Note: Unless the overall frequency and overall gain are adjusted so that the L/R channel levels are the same, there will be a difference between the L/R channels levels in the level and bias adjustments.

7. Then, with the check bar, make sure that the check bar does not come in contact with the tape guide. If it does, turn the screw as shown in Fig. 5 until the check bar does not come in contact with the tape guide.
8. After making these adjustments, insert a tape with the mirror (QZZCRD) and play back the tape. Check if the tape runs smoothly (i.e. does not get twisted).
9. Follow "Head Azimuth Adjustment" procedures on page 19.
10. After following the adjustment procedures, repeat steps 3 to 10 and check if trouble occurs (if it does, remedy it).

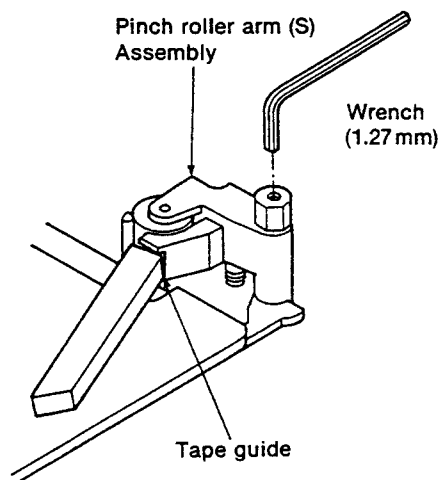

Fig. 5

■ Adjustment procedures when replacing "Pinch Arm S"

1. Install the head alignment gauge and set the play mode.
2. Adjust the height of the pinch arm with the check bar, using the height of tape guide on the head as reference.

■ If the already adjusted "Screw H (Height Adjustment Screw) and Screw T (Tilt Adjustment Screw)" are wrongly turned

- Install the head alignment gauge (QZZ0207), set the play mode, and turn screws H and T until the check bar does not come in contact with the tape guide on the head.
- Then, follows steps 1 to 10 in "Replacing, Installing and Adjusting the Head".

■ Replacing, Installing and Adjusting the Head

Adjustment Screws and Head Screws

1. Remove the head by removing the two head screws (see Fig. 1).
2. Install the head with the two head screws, holding the head facing in the direction of arrow 1 (toward the left) (see Fig. 1).
3. Install the head alignment gauge (QZZ0207) in the mechanism and set the unit to the play mode.
4. With the check bar, check if it comes in contact with the head. (See Figs. 2 and 3)

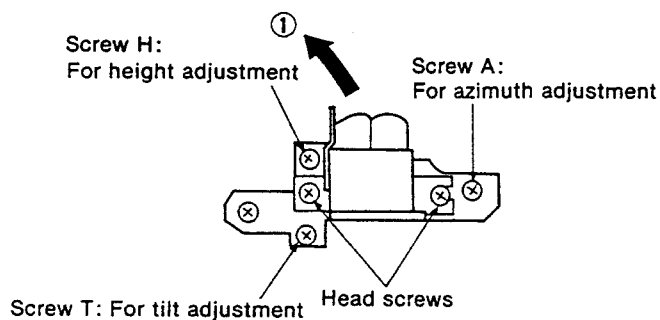

Fig. 1

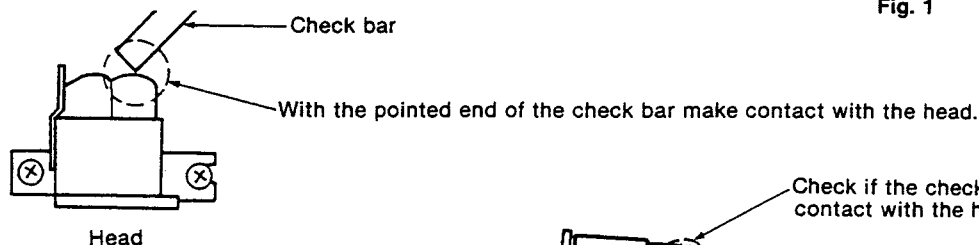

Fig. 2

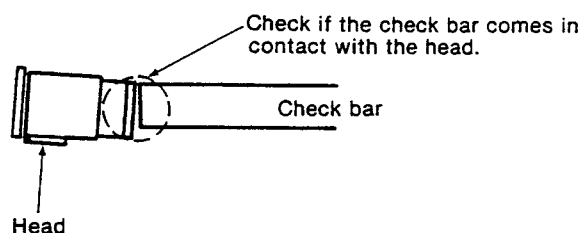

Fig. 3

- * If the check bar and head do not come in contact, adjust the head with the "Tilt Adjustment Screw".
5. With the check bar, make sure that the check bar and tape guide do not come in contact, and visually check that the head is placed horizontally (azimuth aligned).
- * If the check bar comes in contact with the tape guide, make adjustments as follows. (See Fig. 4.)

[If the check bar comes in contact with the top of the tape guide:]

Turn screw H (height adjustment screw) clockwise (as shown in Fig. 1) until the check bar does not come in contact with the tape guide. Then turn screw T (tilt adjustment screw) in the same way as screw H was turned. Finally, turn screw A (azimuth alignment screw) counterclockwise as many degrees as screws H and T were turned.

[If the check bar comes in contact with the bottom of the tape guide:]

Turn screw H (height adjustment screw) counterclockwise until the check bar does not come in contact with the tape guide. Then turn screw T (tilt adjustment screw) in the same way as screw H was turned. Finally, turn screw A (azimuth alignment screw) clockwise as many degrees as screws H and T were turned.

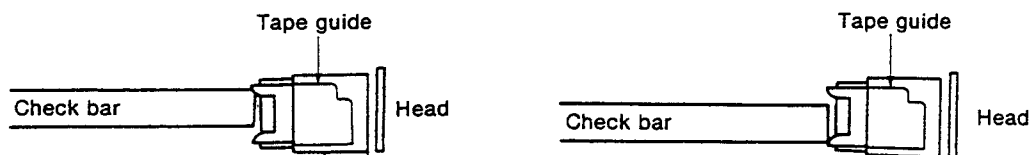
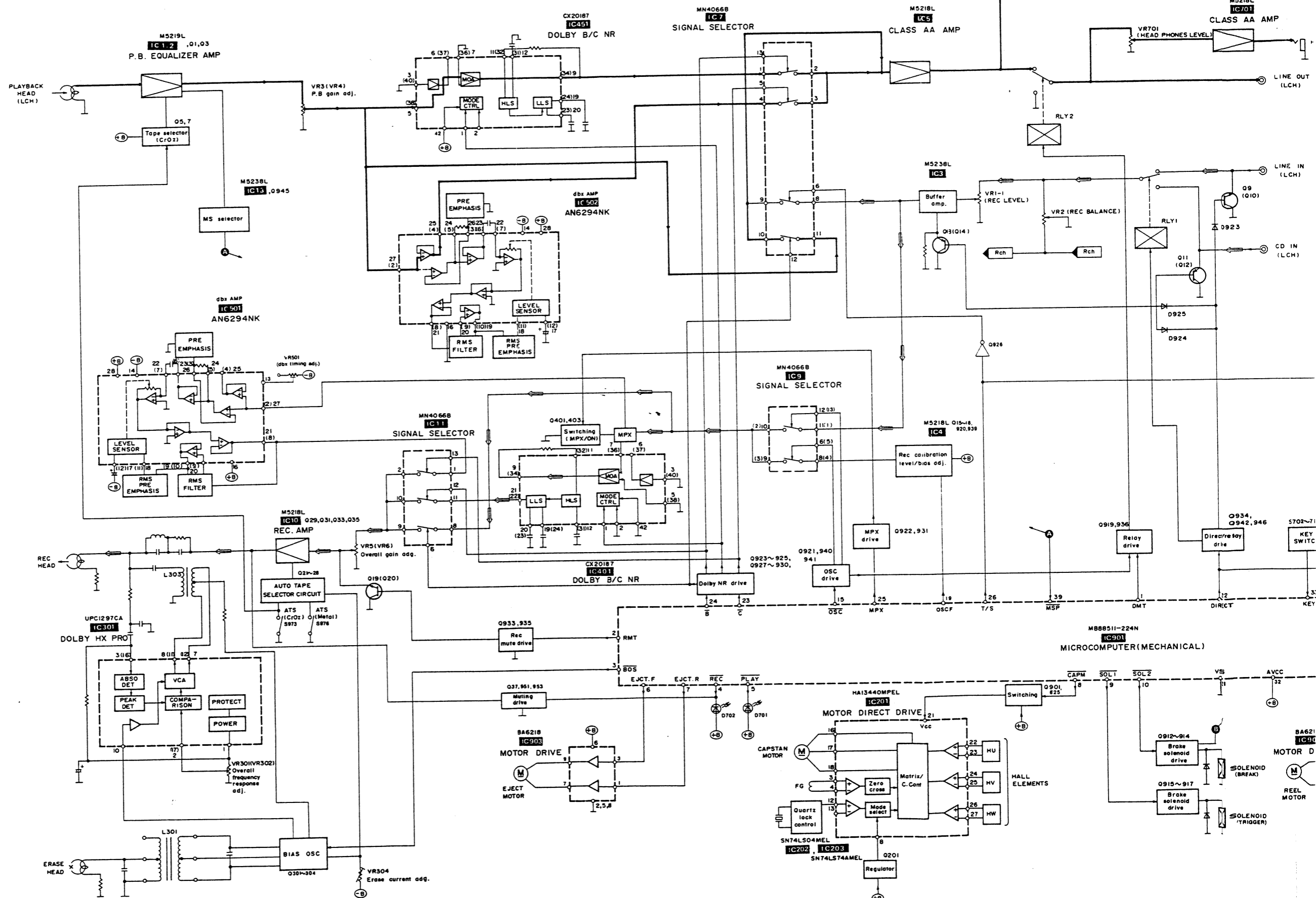
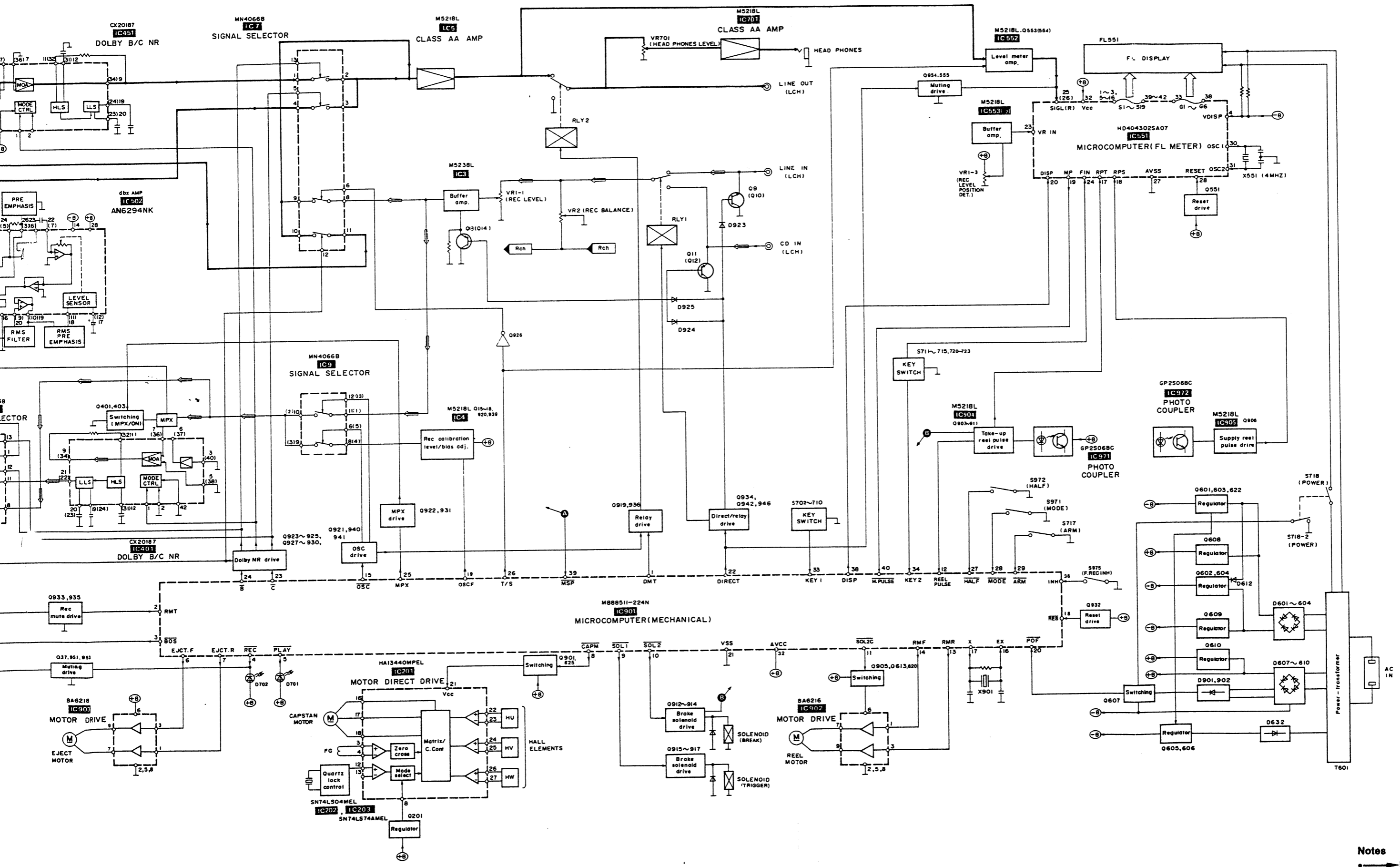

Fig. 4

6. With the check bar, make sure that the check bar does not come in contact with the tape guide on pinch arm S. If it does, make adjustment with a hex wrench (1.27 mm) until the check bar does not come in contact with the pinch arm.

BLOCK DIAGRAM





Notes
 ● Playback signal
 ○ Recording signal

SCHEMATIC DIAGRAM

(Parts list on pages 45~47, 55~58.)

(This schematic diagram may be modified at any time with development of new technology.)

Notes:

- S601 : Voltage selector switch (Voltage selector) in "240V" position. (110V ← 127V ← 220V ← 240V) ((GC) area only.)
- S701 : Stop switch (stop) in "off" position.
- S702 : F.F. switch (ff) in "off" position.
- S703 : Rew switch (rew) in "off" position.
- S704 : Playback switch (Play) in "off" position.
- S705 : Record switch (rec) in "off" position.
- S706 : Pause switch (pause) in "off" position.
- S707 : Dolby noise-reduction switch (Dolby NRC) in "off" position.
- S708 : Dolby noise-reduction switch (Dolby NR B) in "off" position.
- S709 : Multiplex filter switch (MPX filter) in "off" position.
- S710 : Timer switch (timer) in "off" position.
- S711 : Counter reset switch (counter reset) in "off" position.
- S712 : Counter mode switch (counter mode) in "off" position.
- S713 : Meter range switch (meter range) in "off" position.
- S714 : Memory mode switch (memory repeat) in "off" position.
- S715 : Memory mode switch (memory stop) in "off" position.
- S716 : "dbx" switch in "off" position.
- S717 : Automatic-record-muting switch (auto rec mute) in "off" position.
- S718 : Power switch (standby ϕ /on) in "on" position.
- S719 : Open/close switch (open/close) in "off" position.
- S720 : Calibration selector switch (rec cal.) in "off" position.
- S721 : APRS switch (APRS) in "off" position.
- S722 : CD Direct switch (CD Direct) in "off" position.
- S723 : Monitor switch (monitor) in "off" position.
- S801 : Motor switch in "off" position. (Loading)
- S802 : Open switch in "off" position. (Loading)
- S971 : Mode switch in "off" position.
- S972 : Cassette half detection switch in "off" position.
- S973 : ATS (CrO₂) switch in "off" position.
- S975 : Rec Inhibit switch in "off" position.
- S976 : ATS (Metal) switch in "off" position.

- Resistance are in ohms (Ω), 1/4 watt unless specified otherwise.
1K=1,000 (Ω), 1M=1,000k (Ω)
- Capacity are in micro-farads (μ F) unless specified otherwise.
- All voltage values shown in circuitry are under no signal condition and playback mode with volume control at minimum position otherwise specified.

()Voltage values at record mode.
For measurement us EVM.

- Important safety notice
Components identified by Δ mark have special characteristics important for safety. When replacing any of these components, use only manufacturer's specified parts.

- ($\text{---} + B$) indicates +B (bias).
- ($\text{---} - B$) indicates -B (bias).
- ($\text{---} \rightarrow$) indicates the flow of the playback signal.
- ($\text{---} \leftarrow$) indicates the flow of the record signal.

- * **Caution!**
IC and LSI are sensitive to static electricity. Secondary trouble can be prevented by taking care during repair.
- * Cover the parts boxes made of plastics with aluminum foil.
- * Ground the soldering iron.
- * Put a conductive mat on the work table.
- * Do not touch the legs of IC or LSI with the fingers directly.

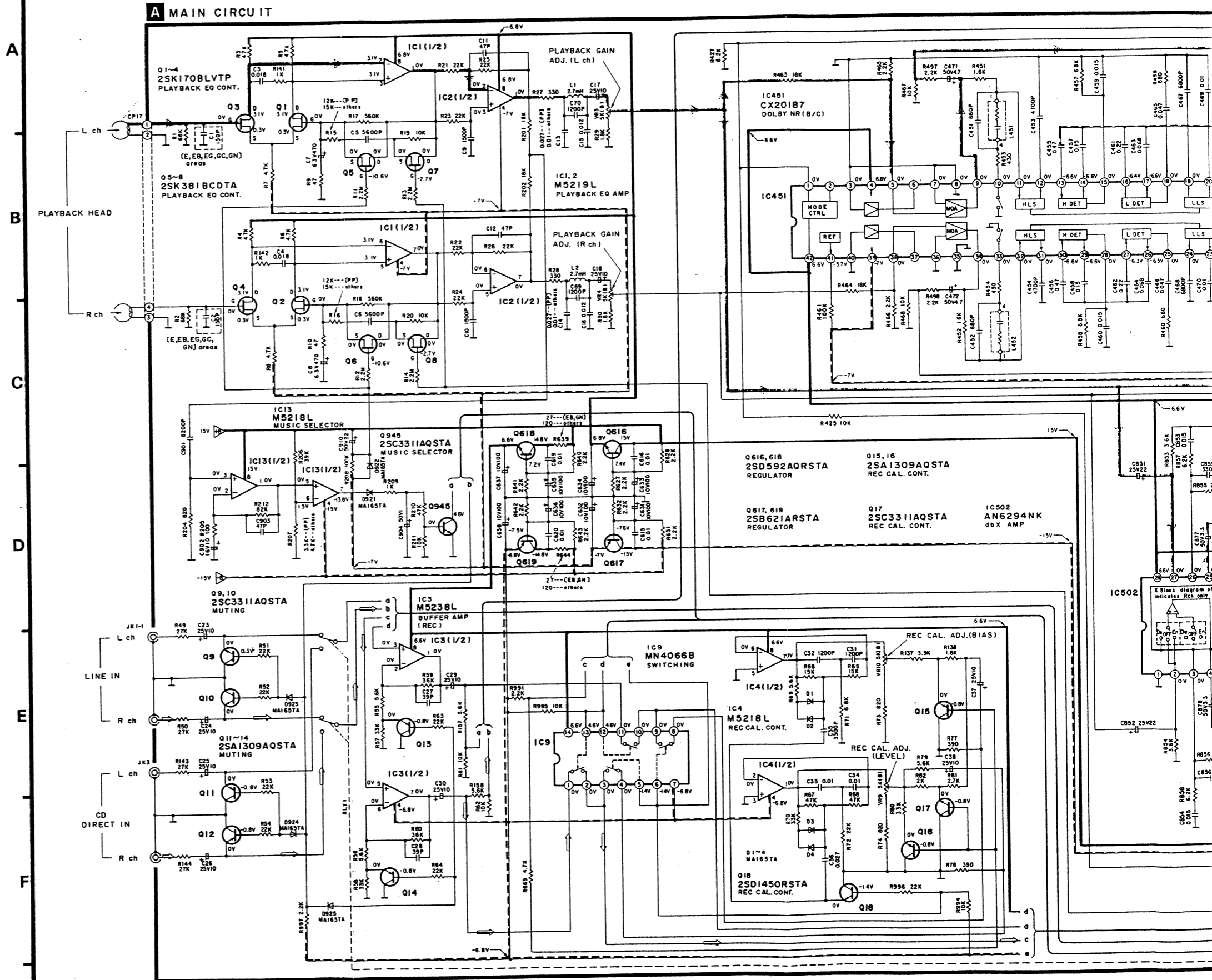

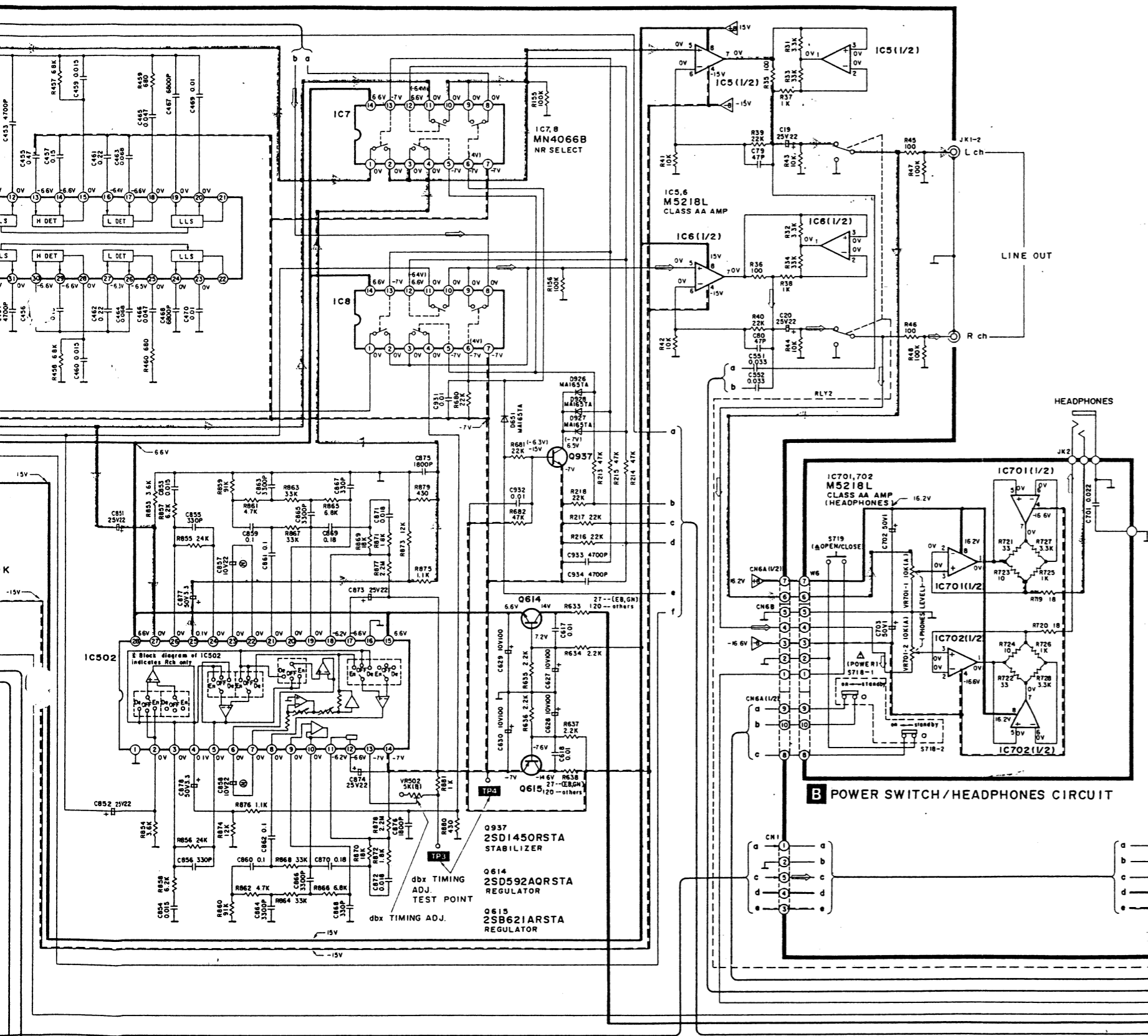

C dbx/DOLBY NR CIRCUIT

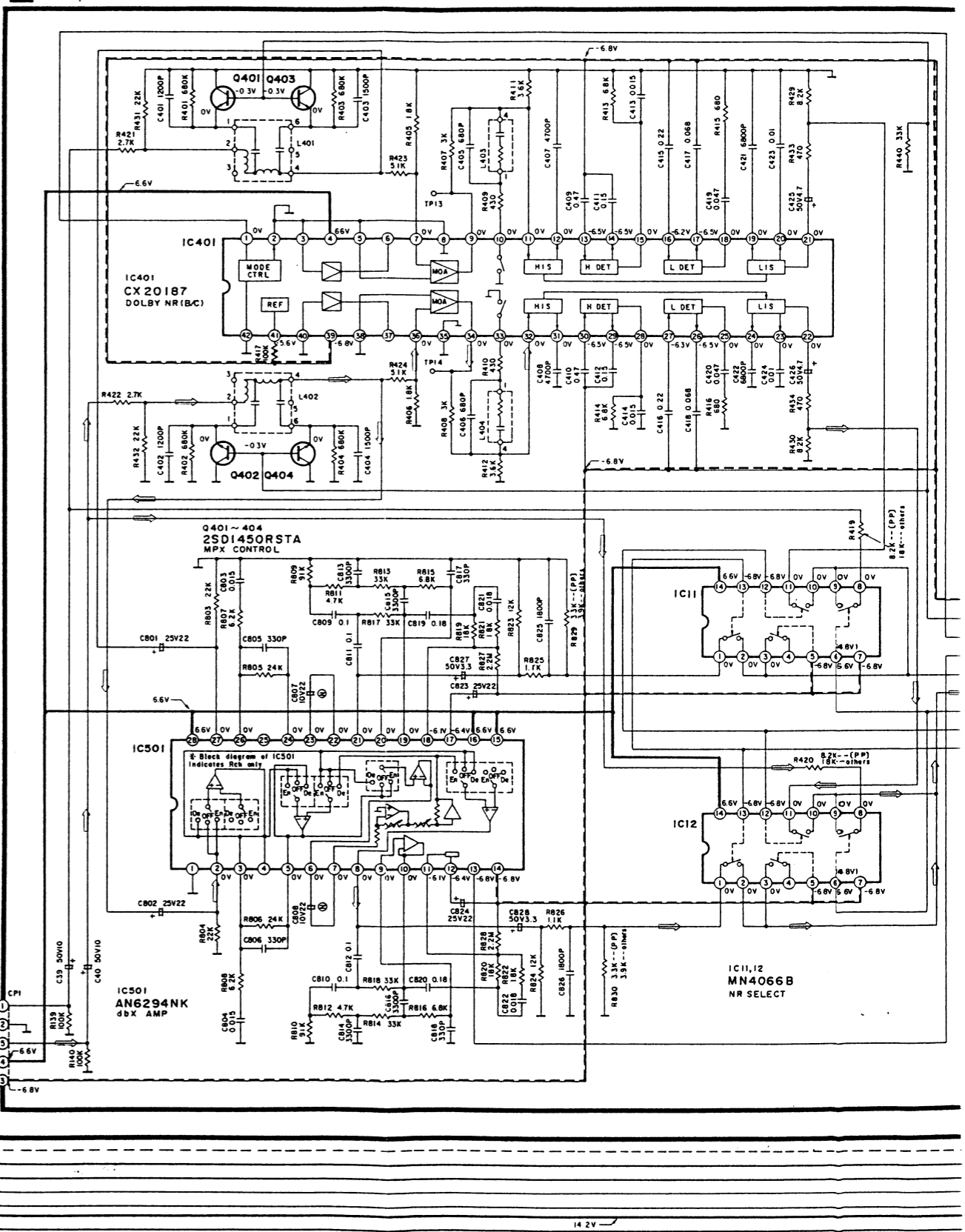

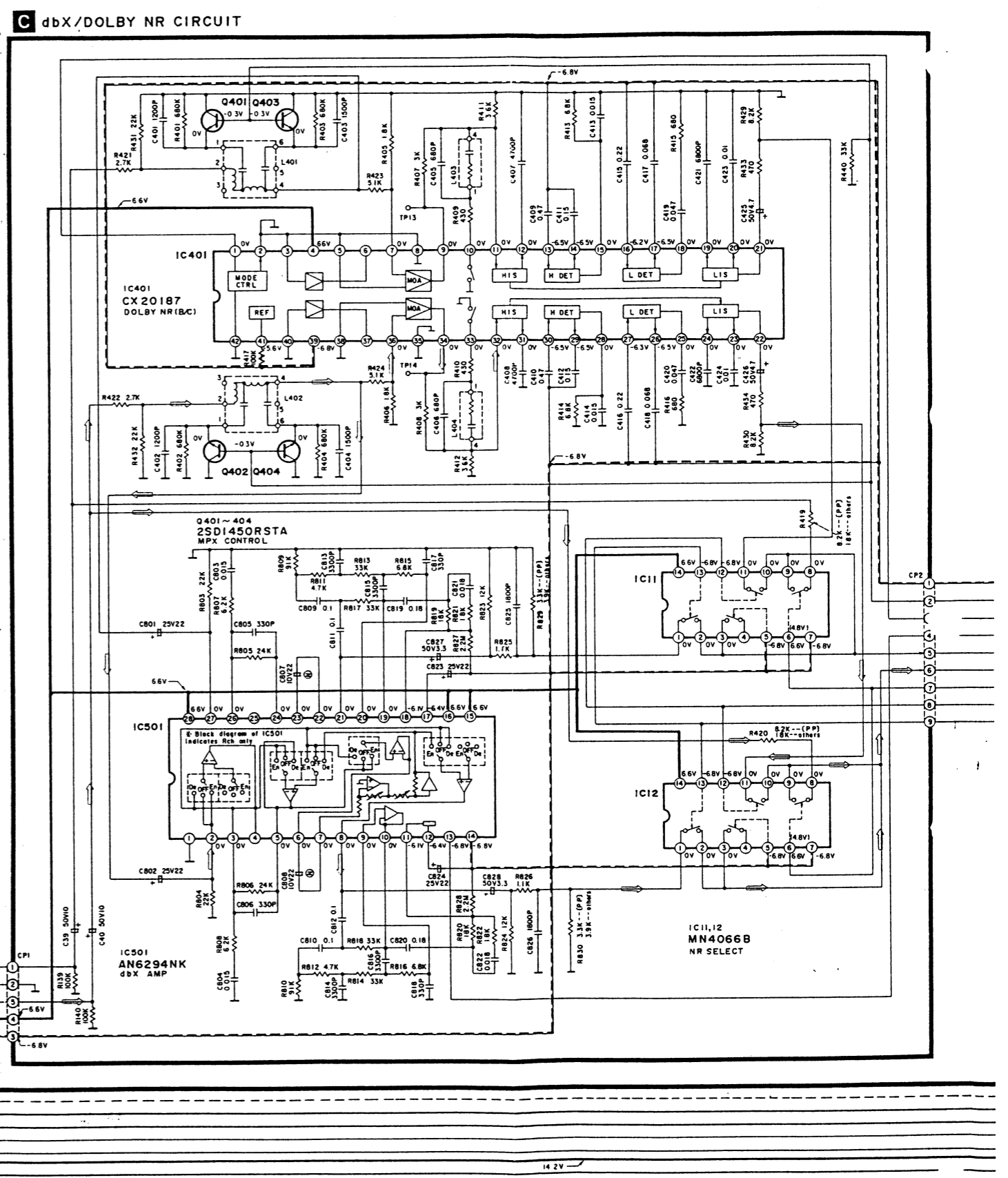
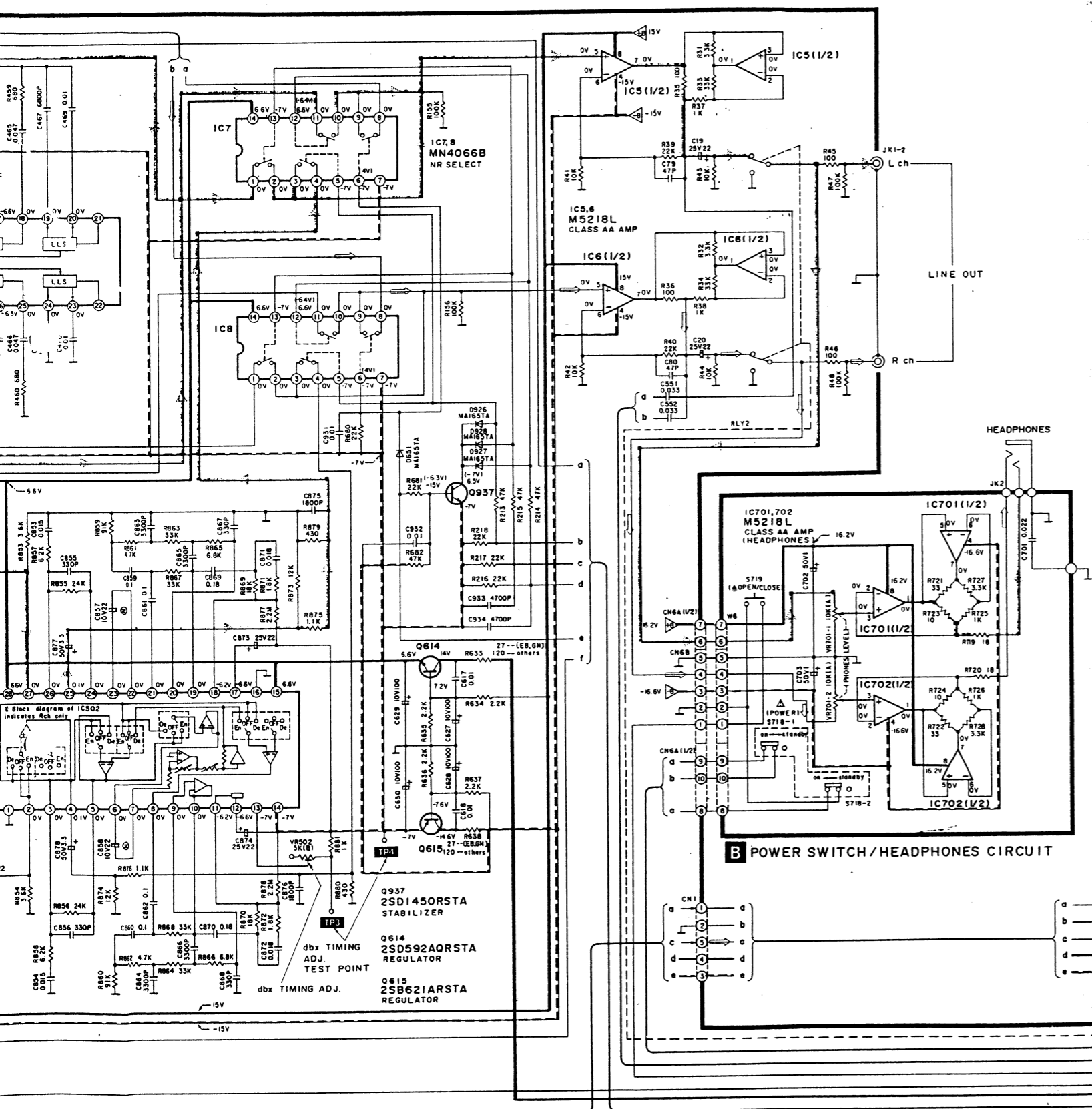

D REC AMP CIRCUIT

Notes: 1. No mark---For (E, EB, EG, GC, GN) areas. 2. (---)---For (PP) area.

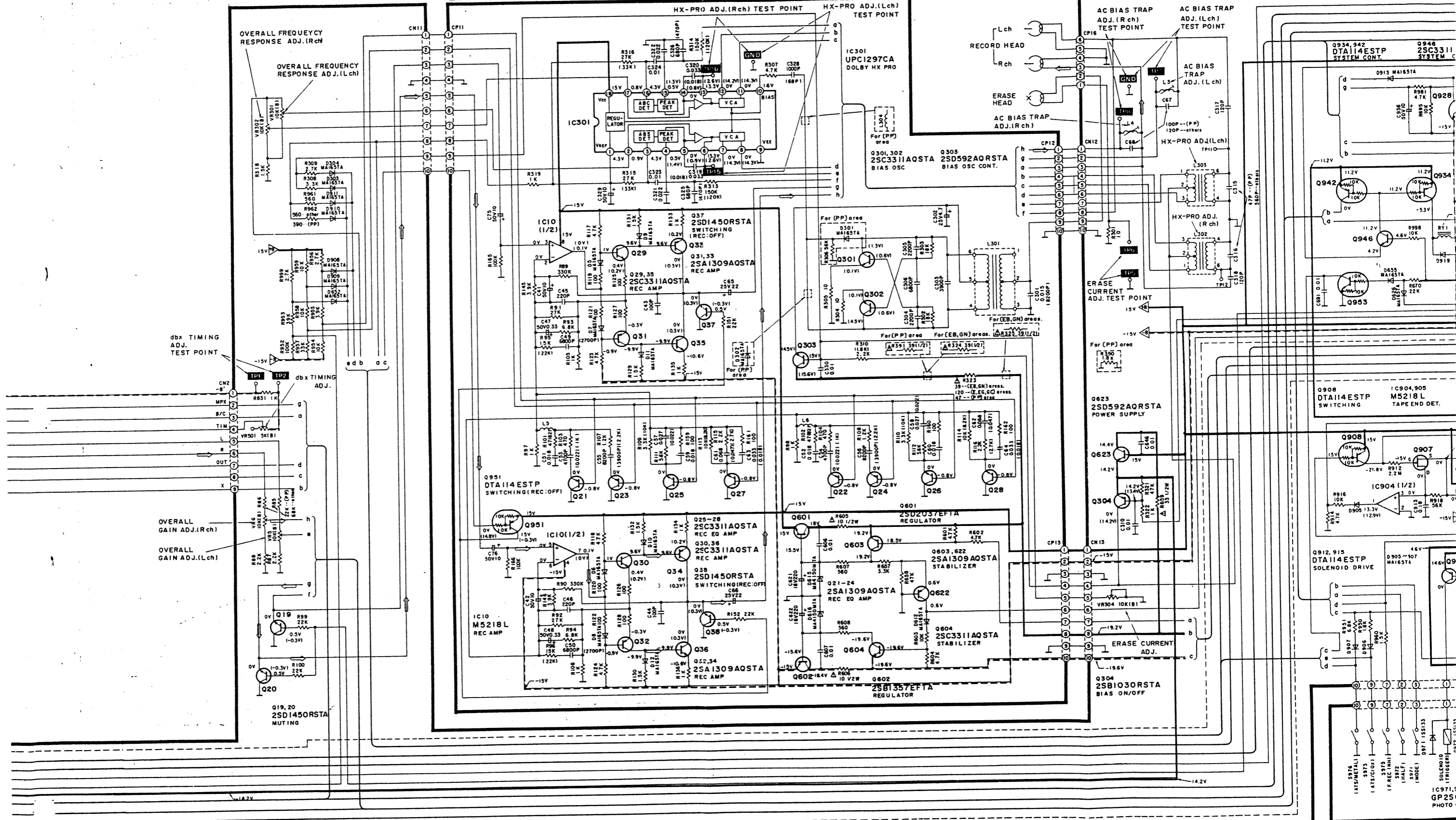

E MECHANISM CIRC

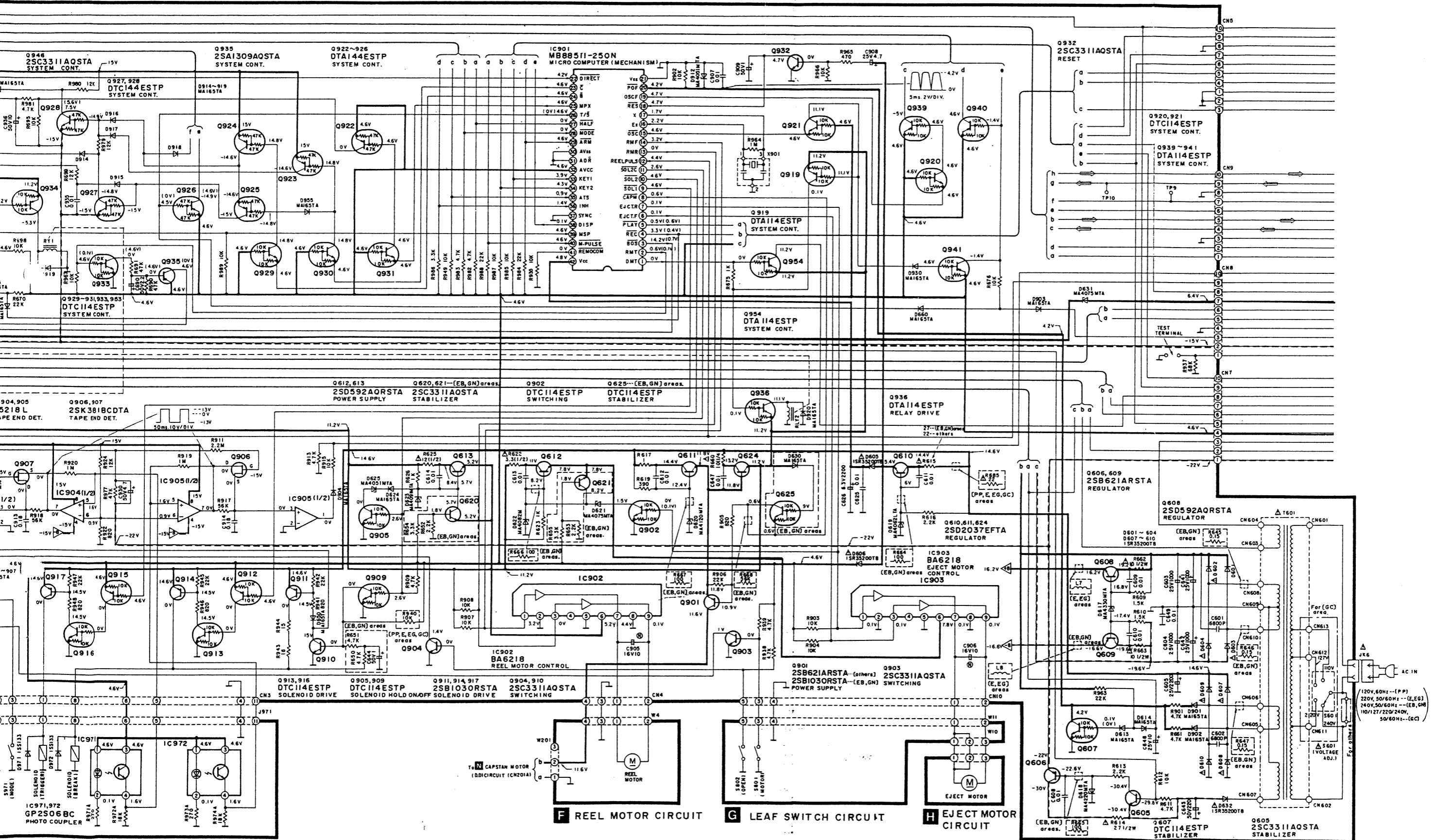

SM CIRCUIT

F REEL MOTOR CIRCUIT

G LEAF SWITCH CIRCUIT

H EJECT MOTOR CIRCUIT

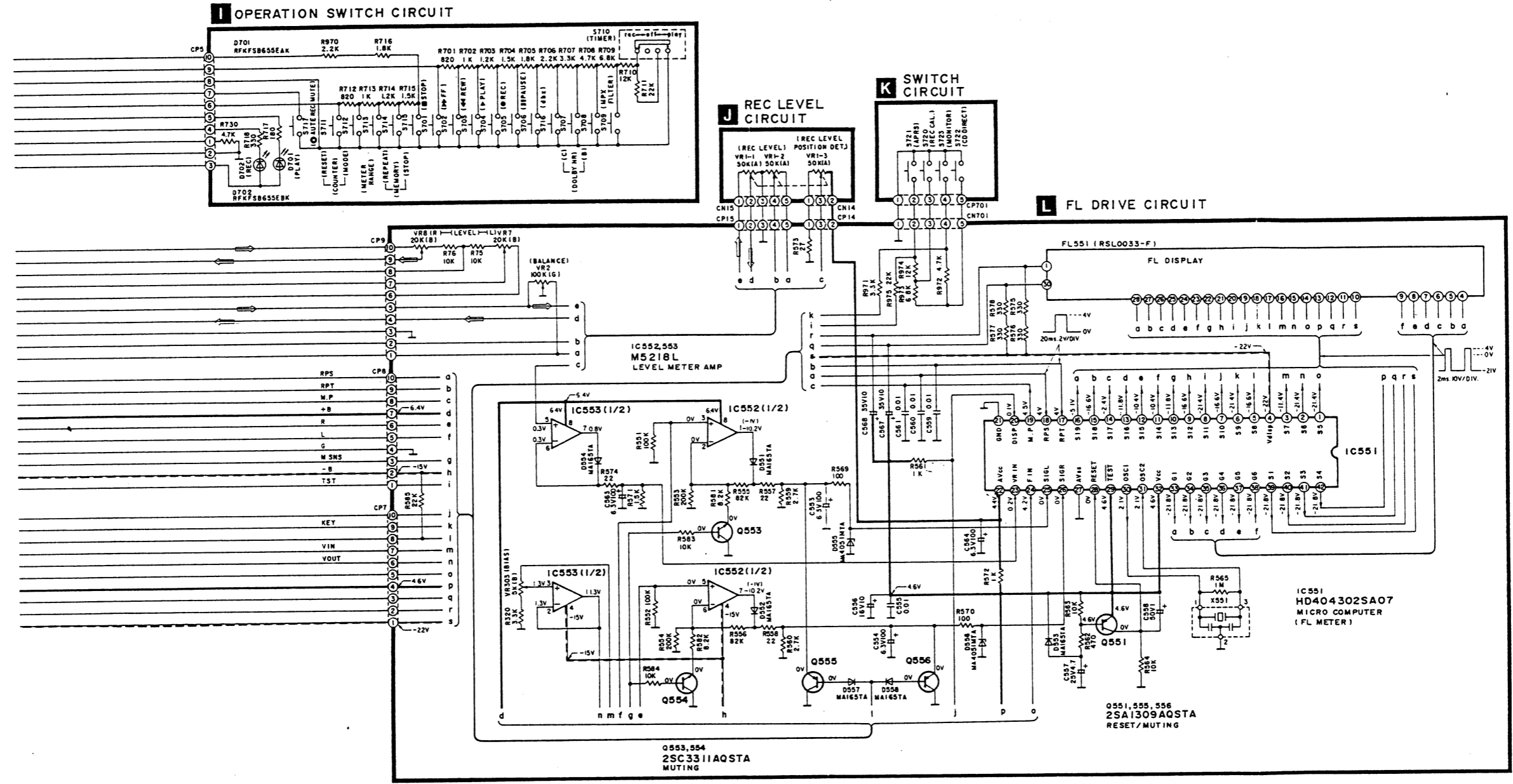

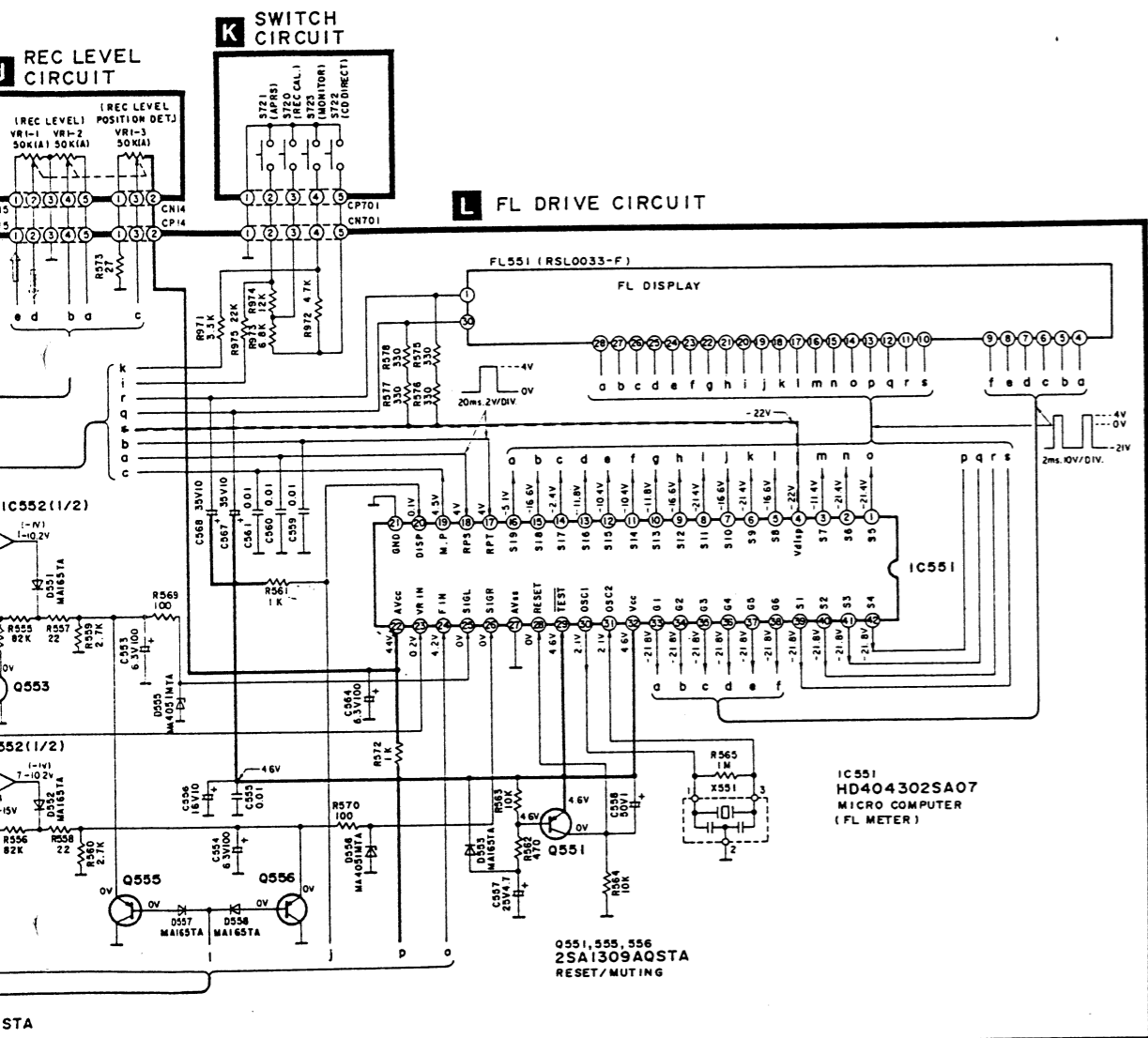

N CAPSTAN MOTOR(D.D) CIRCUIT

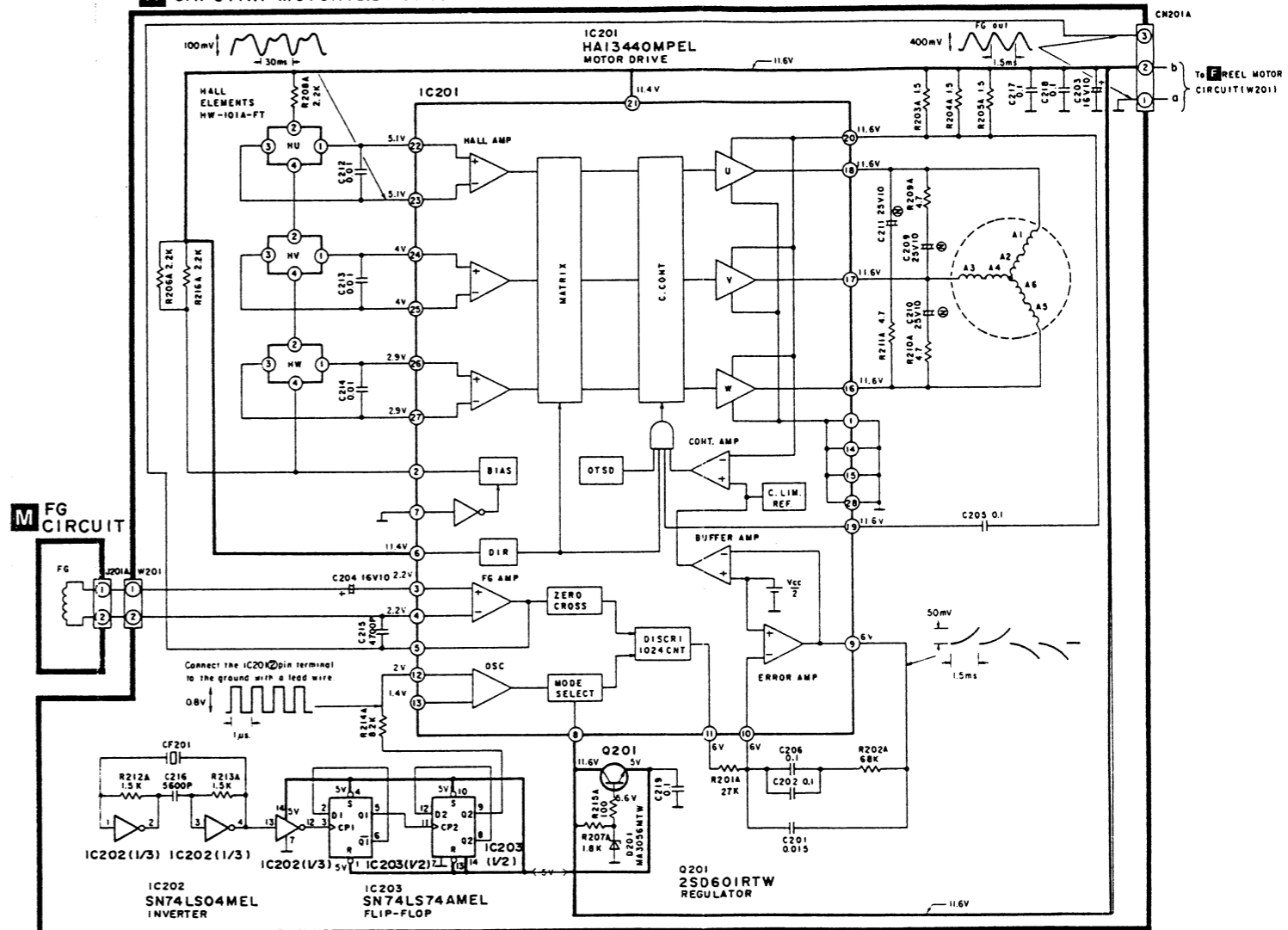

■ TROUBLESHOOTING OF DIRECT DRIVE MOTOR

• OUTLINE OF THE DIRECT DRIVE MOTOR SYSTEM

The capstan motor is actuated by the DD motor digital servo system. The FG pulse is generated after the detection of the zero crosspoint, and the reference signal generated from the quartz oscillator is compared with this FG pulse.

From this comparison, the accelerated and reduced speed pulses are generated, causing the driving coil to function.

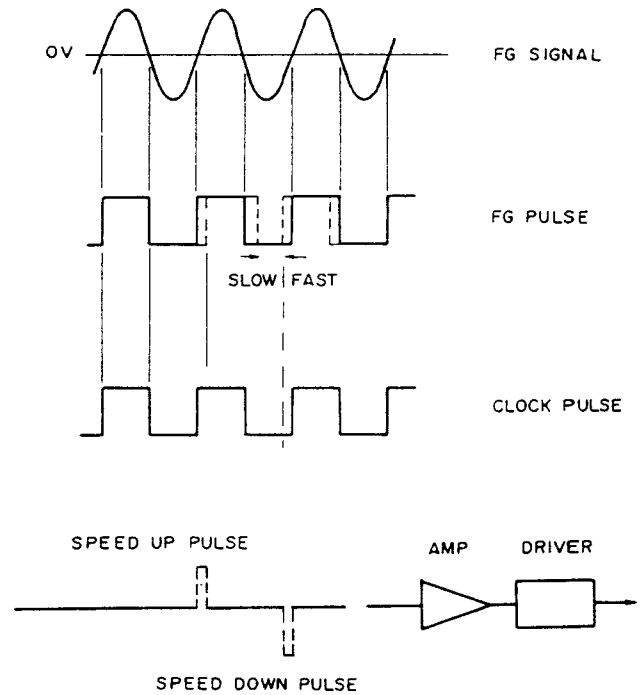





• TROUBLESHOOTING OF DIRECT DRIVE MOTOR

Problem	Possible Cause	Check Points
1. The motor does not rotate.	<ol style="list-style-type: none"> 1. No power supply (+12V) 2. The Hall element has failed (Current does not flow). 3. The ceramic (or crystal) does not oscillate. 	<ul style="list-style-type: none"> • Check the voltage applied to the connector. • Check the DC potential on IC201 pins ②~⑦. * Check the waveform of IC201 pin ②.
2. The motor does not rotate properly. (When pressed, it stops at certain angles. Sometimes it does not rotate even if power is ON.)	<ol style="list-style-type: none"> 1. The coil is broken or not properly soldered. 2. Output of the Hall element is not proper. 	<ul style="list-style-type: none"> * Check the conductance of the coil. If normal, the resistances between IC201 pins ⑯~⑰, ⑰~⑱, ⑱~⑲, will reach 20 ohms. • Check the waveform of IC201 pins ②~⑦.
3. The motor is out of control.	<ol style="list-style-type: none"> 1. The FG coil is broken. 	<ul style="list-style-type: none"> • Check the waveform of IC pin ⑤. • Check if the FG coil is broken.
4. Abnormal wow	<ol style="list-style-type: none"> 1. Same as those described for problem 2. 	

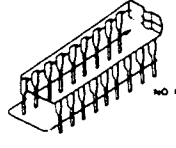
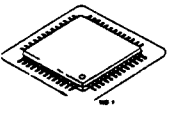
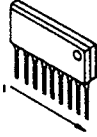
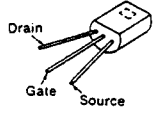
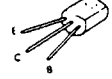
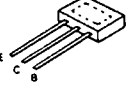
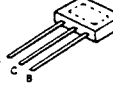
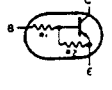
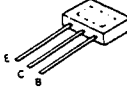
Note: Check the points marked with an asterisk (*) by removing the DD motor control P.C.B. and then connecting IC201 pin ② to GND with a lead wire. (After the DD motor control P.C.B. is removed, current will start flowing through the coil, heating the IC.)

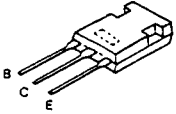
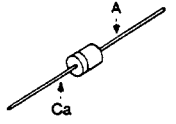
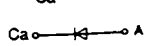
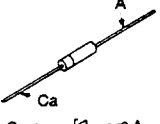
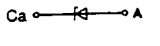
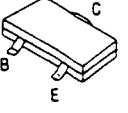
■ TERMINAL GUIDE OF IC'S, TRANSISTORS AND DIODES

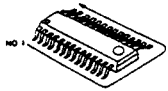
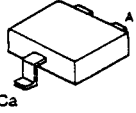
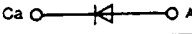
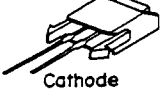
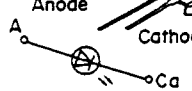
	<table border="1"> <tr><td>MN4066B</td><td>14 Pin</td></tr> <tr><td>UPC1297CA</td><td>18 Pin</td></tr> <tr><td>AN6294NK</td><td>28 Pin</td></tr> <tr><td>CX20187</td><td>42 Pin</td></tr> <tr><td>HD404302SA07</td><td>42 Pin</td></tr> <tr><td>MB88511-250N</td><td>42 Pin</td></tr> </table>	MN4066B	14 Pin	UPC1297CA	18 Pin	AN6294NK	28 Pin	CX20187	42 Pin	HD404302SA07	42 Pin	MB88511-250N	42 Pin	 <table border="1"> <tr><td>HA13440MPEL</td><td>28 Pin</td></tr> </table>	HA13440MPEL	28 Pin	 <table border="1"> <tr><td>M5238L</td><td>8 Pin</td></tr> <tr><td>M5219L</td><td>8 Pin</td></tr> <tr><td>M5218L</td><td>8 Pin</td></tr> <tr><td>BA6218</td><td>9 Pin</td></tr> </table>	M5238L	8 Pin	M5219L	8 Pin	M5218L	8 Pin	BA6218	9 Pin	<table border="1"> <tr><td>2SK381BCDTA</td><td></td></tr> <tr><td>2SK170BLV</td><td></td></tr> </table> 	2SK381BCDTA		2SK170BLV	
MN4066B	14 Pin																													
UPC1297CA	18 Pin																													
AN6294NK	28 Pin																													
CX20187	42 Pin																													
HD404302SA07	42 Pin																													
MB88511-250N	42 Pin																													
HA13440MPEL	28 Pin																													
M5238L	8 Pin																													
M5219L	8 Pin																													
M5218L	8 Pin																													
BA6218	9 Pin																													
2SK381BCDTA																														
2SK170BLV																														
 <table border="1"> <tr><td>2SB621ARSTA</td><td></td></tr> <tr><td>2SD592AQRSTA</td><td></td></tr> </table>	2SB621ARSTA		2SD592AQRSTA		 <table border="1"> <tr><td>2SA1309AQSTA</td><td></td></tr> <tr><td>2SC3311AQSTA</td><td></td></tr> <tr><td>2SD1450RSTA</td><td></td></tr> <tr><td>2SB1030RSTTA</td><td></td></tr> </table>	2SA1309AQSTA		2SC3311AQSTA		2SD1450RSTA		2SB1030RSTTA		<table border="1"> <tr><td>DTC114ESTP</td><td></td></tr> <tr><td>DTC144ESTP</td><td></td></tr> </table>  	DTC114ESTP		DTC144ESTP		<table border="1"> <tr><td>DTA114ESTP</td><td></td></tr> <tr><td>DTA144ESTP</td><td></td></tr> </table>  	DTA114ESTP		DTA144ESTP								
2SB621ARSTA																														
2SD592AQRSTA																														
2SA1309AQSTA																														
2SC3311AQSTA																														
2SD1450RSTA																														
2SB1030RSTTA																														
DTC114ESTP																														
DTC144ESTP																														
DTA114ESTP																														
DTA144ESTP																														
 <table border="1"> <tr><td>2SB1357EFTA</td><td></td></tr> <tr><td>2SD2037EFTA</td><td></td></tr> </table>	2SB1357EFTA		2SD2037EFTA		 <table border="1"> <tr><td>MA165TA</td><td></td></tr> <tr><td>1SR35200TB</td><td></td></tr> <tr><td>1SS133</td><td></td></tr> </table> 	MA165TA		1SR35200TB		1SS133		 	<table border="1"> <tr><td>MA4051MTA</td><td>MA4091MTA</td></tr> <tr><td>MA4062LTA</td><td>MA4120MTA</td></tr> <tr><td>MA4075MTA</td><td>MA4220</td></tr> <tr><td>MA4082MTA</td><td>MA4330MTA</td></tr> <tr><td>MA4150MTA</td><td></td></tr> </table>	MA4051MTA	MA4091MTA	MA4062LTA	MA4120MTA	MA4075MTA	MA4220	MA4082MTA	MA4330MTA	MA4150MTA								
2SB1357EFTA																														
2SD2037EFTA																														
MA165TA																														
1SR35200TB																														
1SS133																														
MA4051MTA	MA4091MTA																													
MA4062LTA	MA4120MTA																													
MA4075MTA	MA4220																													
MA4082MTA	MA4330MTA																													
MA4150MTA																														
<table border="1"> <tr><td>2SD601RTW</td><td></td></tr> </table>  	2SD601RTW		<table border="1"> <tr><td>SN74LS04MEL</td><td>14 Pin</td></tr> <tr><td>SN74LS74MEL</td><td>14 Pin</td></tr> </table> 	SN74LS04MEL	14 Pin	SN74LS74MEL	14 Pin	<table border="1"> <tr><td>MA3056MTW</td><td></td></tr> </table>  	MA3056MTW		<table border="1"> <tr><td>RFKFSB655EAK</td><td></td></tr> <tr><td>RFKFSB655EBK</td><td></td></tr> </table>  	RFKFSB655EAK		RFKFSB655EBK																
2SD601RTW																														
SN74LS04MEL	14 Pin																													
SN74LS74MEL	14 Pin																													
MA3056MTW																														
RFKFSB655EAK																														
RFKFSB655EBK																														

INTERNAL CONNECTION OF FL

• Grid connection diagram

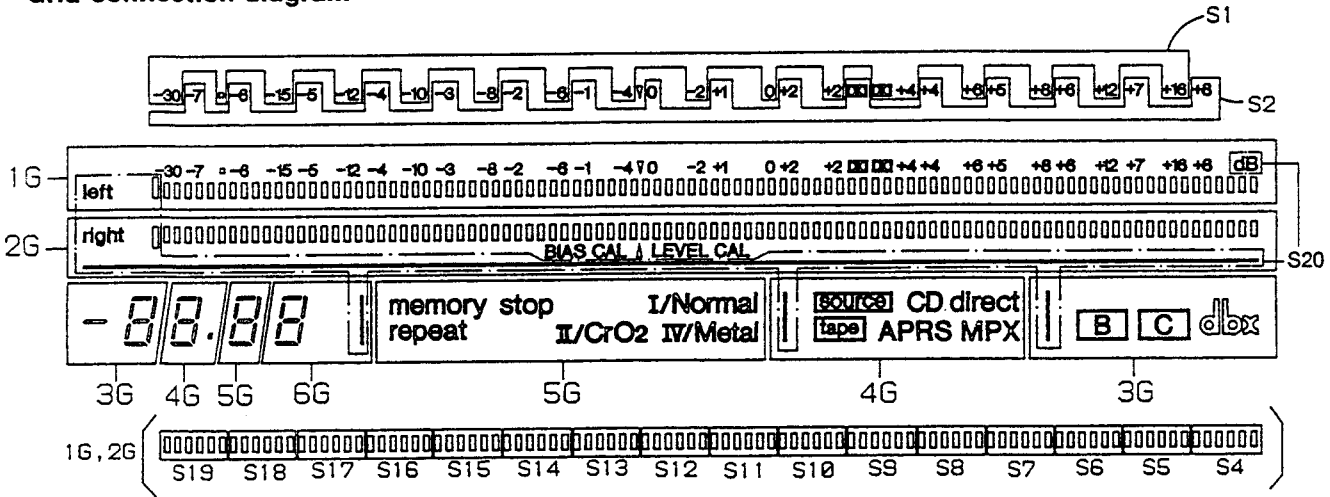

• Anode connection table

	1G	2G	3G	4G	5G	6G
S1	S1	LEVEL CAL	-	APRS	-	-
S2	S2	BIAS CAL	-	-	-	-
S3	▼	▲	-	-	-	-
S4			-	-	-	-
S5			-	-	-	-
S6			-	-	memory	-
S7			-	-	repeat	-
S8			-	tape	stop	-
S9			B	source	-	-
S10			C	CD direct	I /Normal	-
S11			dbx	MPX	II /CrO ₂	-
S12			—	▪	IV/Metal	-
S13			a	a	a	a
S14			b	b	b	b
S15			f	f	f	f
S16			g	g	g	g
S17			c	c	c	c
S18			e	e	e	e
S19			d	d	d	d
S20	left	dB right			-	

• Pin connection

PIN NO.	40	39	38	37	36	35	34	33	32	31	30	29	28	27	26	25	24	23	22	21	20	19	18	17	16	15	14	13	12	11	10	9	8	7	6	5	4	3	2	1		
CONNECTION	N	N	N	N	S	S	S	S	S	S	S	S	S	S	S	S	S	S	S	S	S	S	N	6	5	4	3	2	1	S	N	N	N	N	N	N	N	N	N	F	F	
	P	P	P	P	19	18	17	16	15	14	13	12	11	10	9	8	7	6	5	4	3	2	1	C	G	G	G	G	G	G	20	P	P	P	P	P	P	P	P	P	1	1
PIN NO.	55	54	53	52	51	50	49	48	47	46	45	44	43	42	41																											
CONNECTION	F	F	N	N	N	N	N	N	N	N	N	N	N	N	N																											
	2	2	P	P	P	P	P	P	P	P	P	P	P	P	P																											

WIRING CONNECTION DIAGRAM

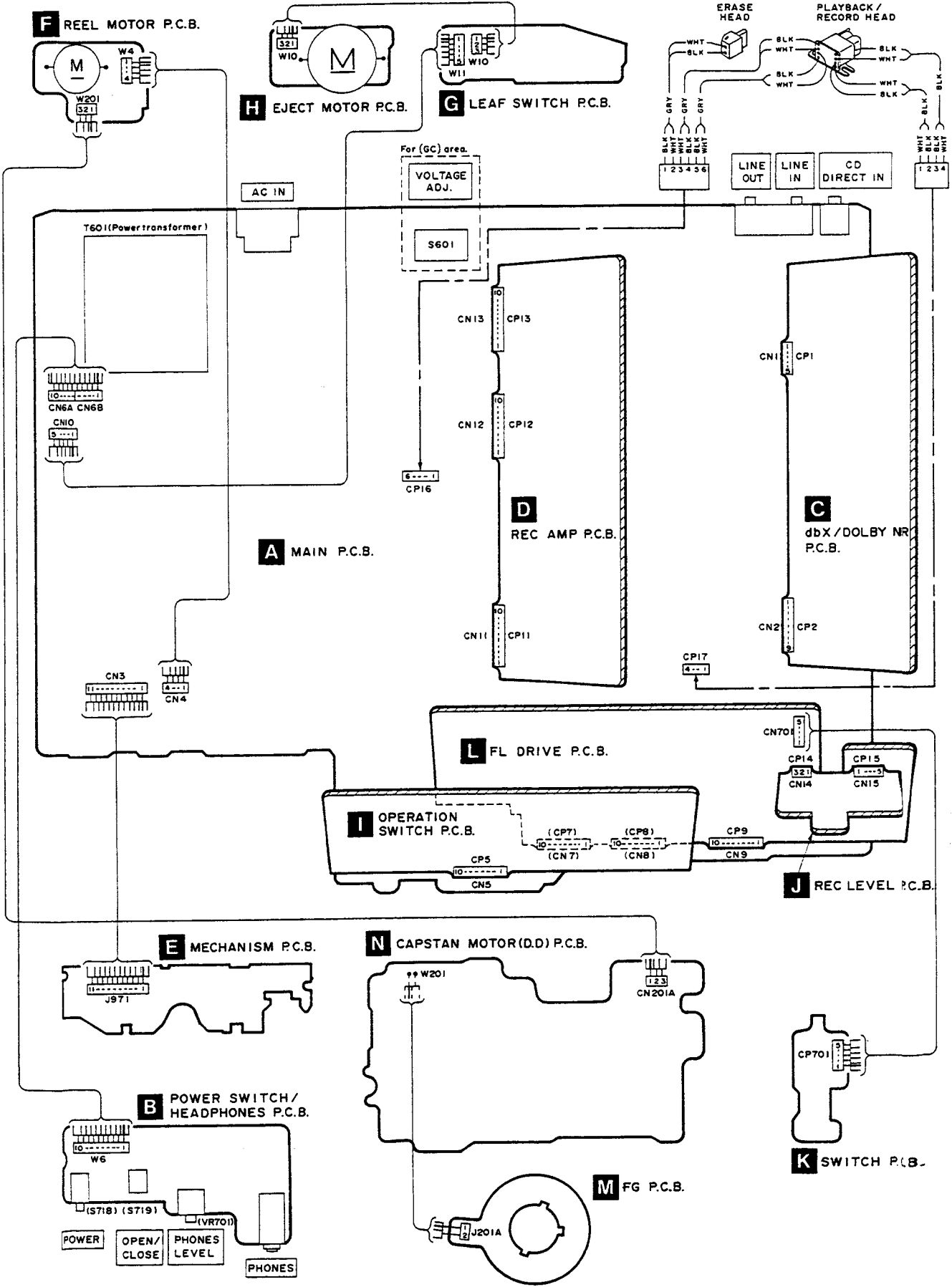



PRINTED CIRCUIT BOARDS

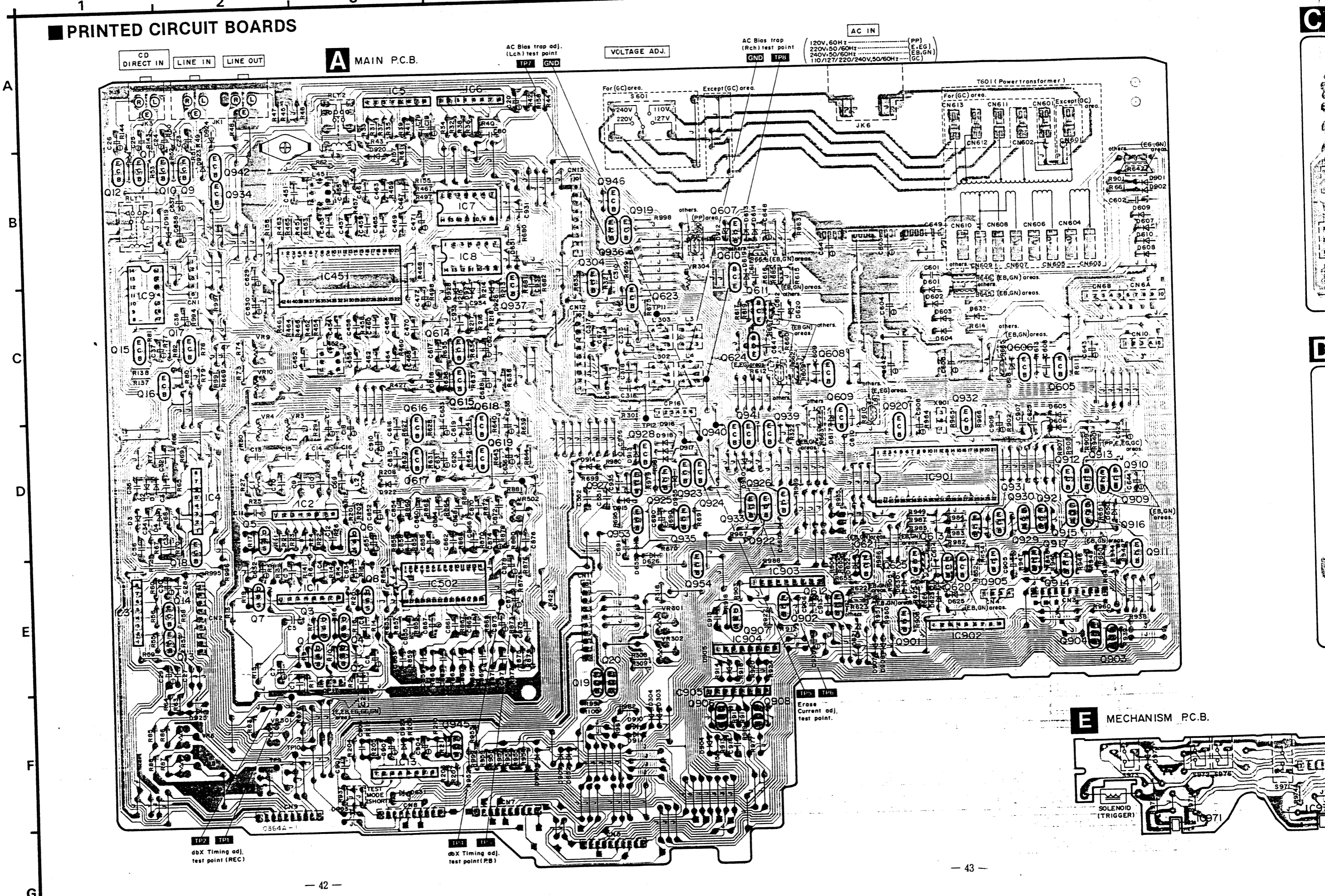

B POWER SWITCH/HEADPHONES P.C.B.

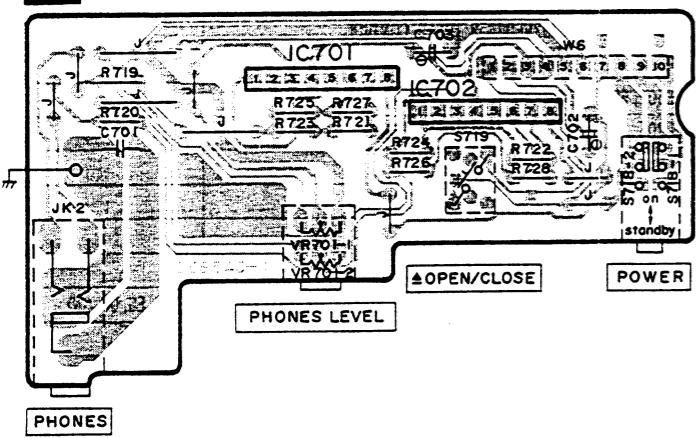

L FL DRIVE P.C.B.

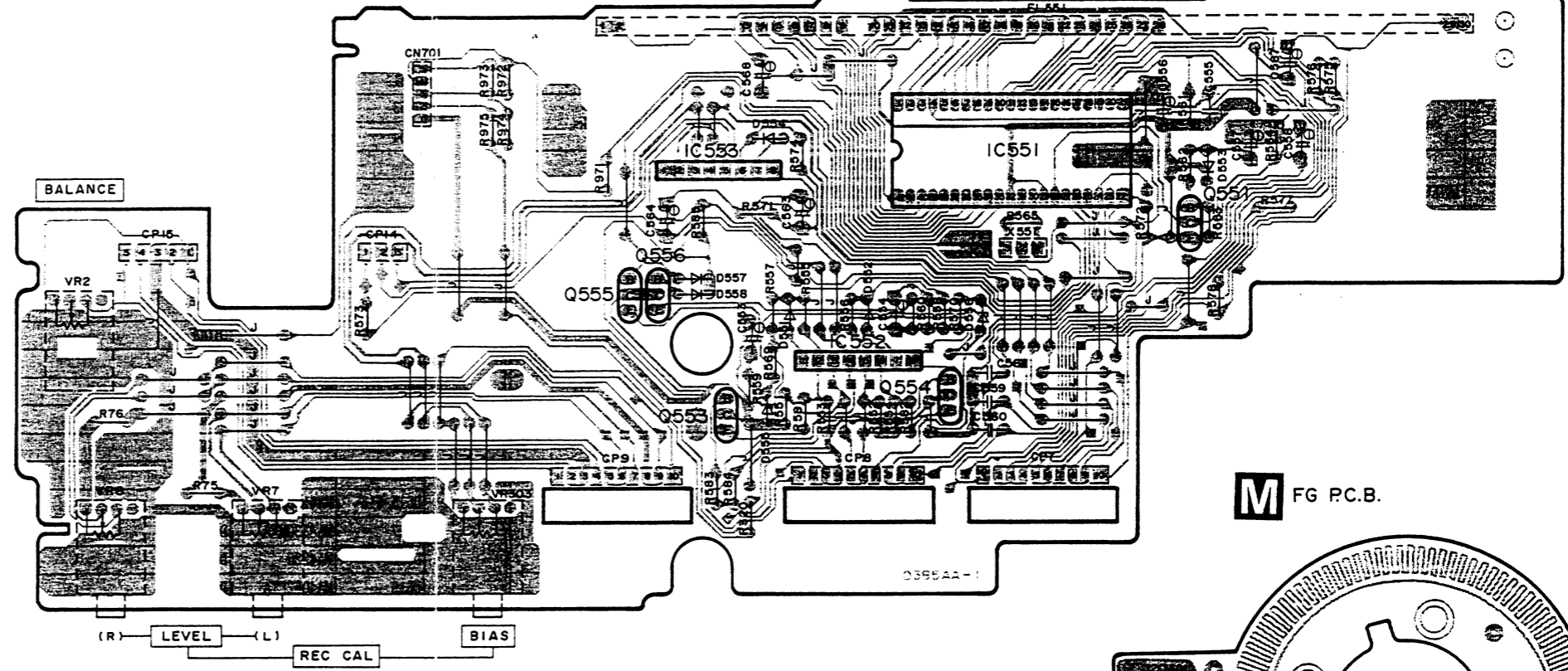

H EJECT MOTOR P.C.B.

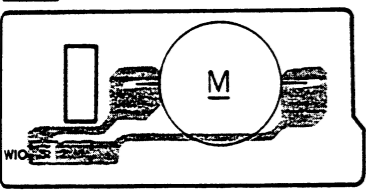

J REC LEVEL P.C.B.

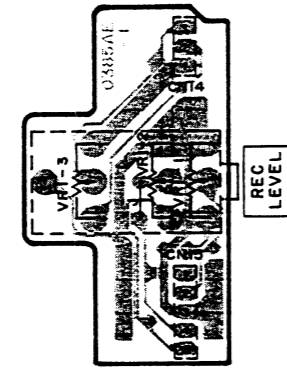

K SWITCH P.C.B.

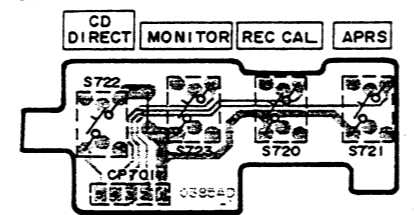

M FG P.C.B.

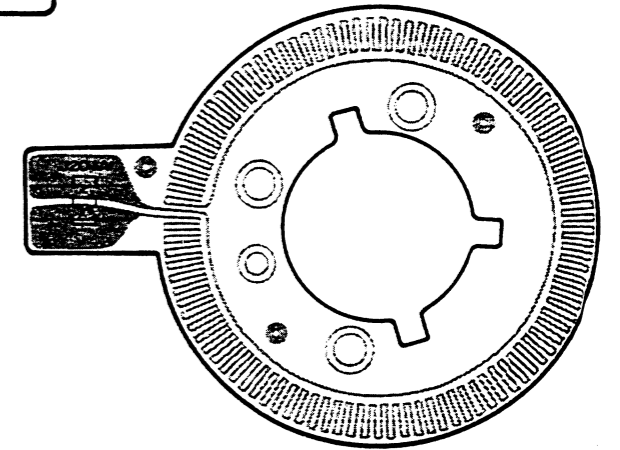

I OPERATION SWITCH P.C.B.

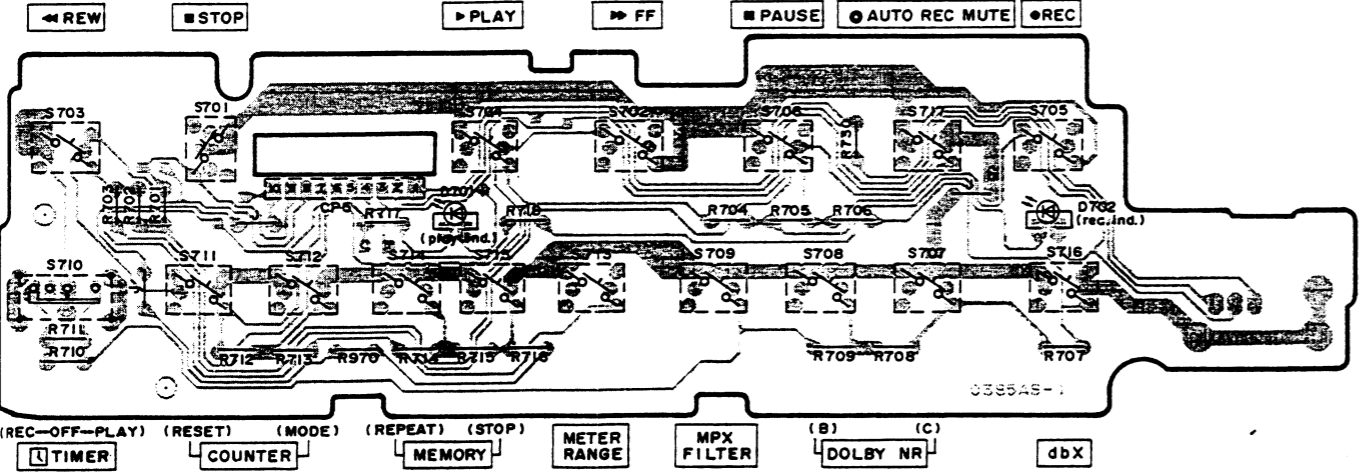

N CAPSTAN MOTOR (D.D) P.C.B.

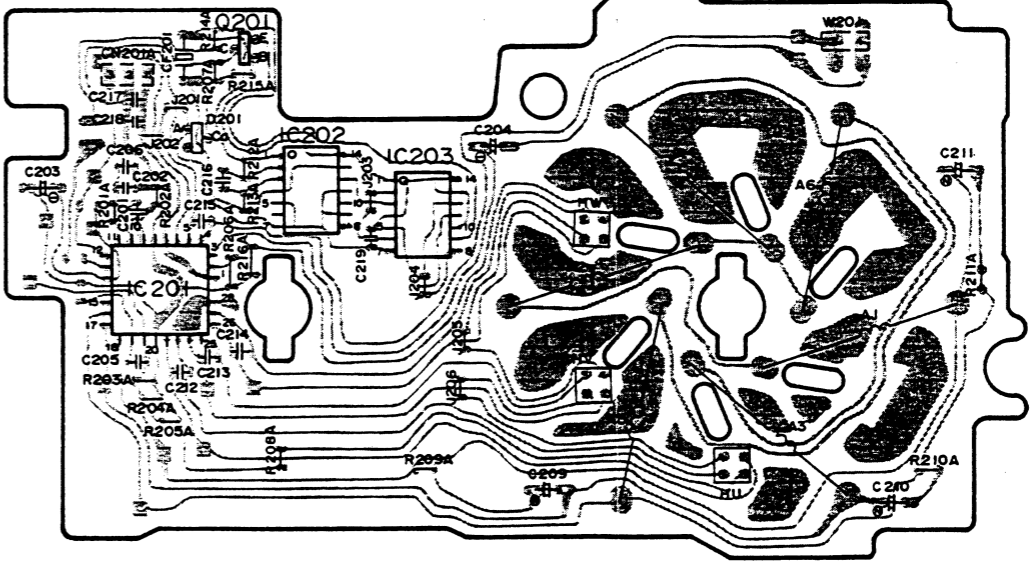

Ref.No.	Part No.	Part Name & Description	Remarks	Ref.No.	Part No.	Part Name & Description	Remarks
S715	EVQQTG05R	MEMORY (STOP)		JK1	SJF3069A	TERMINAL BOARD (4P)	
S716	EVQQTG05R	dbx		JK2	SJJD19	JACK, HEADPHONES	
S717	EVQQTG05R	ARM		JK3	SJF3068A	TERMINAL BOARD (2P)	
S718	SSH1238	POWER	△	JK6	SJS9236	AC INLET	(E, EB, EG, GC) △
S719	EVQQTG05R	OPEN/CLOSE		JK6	SJSD16	AC INLET	(PP, GN) △
S720	EVQQTG05R	CALIBRATION SELECTOR					
S721	EVQQTG05R	APRS				RELAY (S)	
S722	EVQQTG05R	CD DIRECT					
S723	EVQQTG05R	MONITOR		RY1. 2	AG80239	RELAY (5V)	
S801	SSPD18-1	MOTOR					
S802	SSPD18-1	OPEN				CERAMIC FILTER (S)	
S971	RSH1A89Z	MODE					
S972	RSH1A90Z	HALF		CF201	RSXA3M75S01	CERAMIC FILTER	
S973	RSH1A90Z	ATS					
S975	RSH1A90Z	REC INHIBIT					
S976	RSH1A90Z	ATS					
		CONNECTOR (S) AND SOCKET (S)					
CN1	SJS50578JQ	SOCKET (5P)					
CN2	SJS50978JQ	SOCKET (9P)					
CN3	SJSD1105	CONNECTOR (11P)					
CN4	RJS1A1704	CONNECTOR (4P)					
CN5	RJU003KD10M1	SOCKET (10P)					
CN6A, 6B	RJS1A1705	CONNECTOR (5P)					
CN7-9	RJU003KD10M1	SOCKET (10P)					
CN10	RJS1A1705	CONNECTOR (5P)					
CN11-13	SJS51078JQ	SOCKET (7P)					
CN14	SJT30345JQ	CONNECTOR (3P)					
CN15	SJT30545JQ	CONNECTOR (5P)					
CN201A	RJS3T4ZA	CONNECTOR (3P)					
CN601-610	RJS1A1101	SOCKET (1P)					
CN611-613	RJS1A1101	SOCKET (1P)	(GC)				
CN701	SJT30549BB1	CONNECTOR (5P)					
CP1	SJT30545JQ	CONNECTOR (5P)					
CP2	SJT30945JQ	CONNECTOR (9P)					
CP5	RJT003KD10M1	CONNECTOR (10P)					
CP7-9	RJT003KD10M1	CONNECTOR (10P)					
CP11-13	SJT31045JQ	CONNECTOR (10P)					
CP14	SJS50378JQ	SOCKET (3P)					
CP15	SJS50578JQ	SOCKET (5P)					
CP16	SJTD613	CONNECTOR (6P)					
CP17	SJTD413	CONNECTOR (4P)					
CP701	SJS50581BB	SOCKET (5P)					
		GND PART (S)					
E1, E2	SNE1004-1	GND PLATE					
E3	SUSD165	GND SPRING					
		JACK (S)					

Ref. No.	Part No.	Part Name & Description	Remarks	Ref. No.	Part No.	Part Name & Description	Remarks
		MECHANISM PARTS LIST		147	RDG0034	REEL MOTOR GEAR	
				148	XSN26+4	SCREW	
				149	XTN2+3F	SCREW	
101	XYN2+C4	SCREW		150	RMRO141	THRUST BEARING	
102	RBR4CY004-C	R/P HEAD	(PP)	151	REPO268B	STATER P. C. B. ASS'Y	
102	SJH104-1	R/P HEAD	(E, EB, EG, GC, GN)	152	RUB428Z	MOVING IRON CORE	
103	XSN2+10	SCREW		153	RSJ0003	SOLENOID	
104	RHD20005	SCREW		154	RXQ0011	BRAKE SOLENOID	
105	RMBO135	SPRING		155	XTN26+4F	SCREW	
106	RMBO137	SPRING		156	RDG0030	MAIN GEAR	
107	XSN2+8	SCREW		157	RXF0018	FLYWHEEL (D)	
108	RBR2CY008-A	E HEAD		158	RXF0013	FLYWHEEL (S)	
109	RMA0271	HEAD PLATE		159	RDV0012	BELT	
110	RMRO249	TAPE GUIDE		160	RMBO138	SPRING	
111	XTN2+5F	SCREW		161	RHW21011	WASHER	
112	RMBO136	SPRING		162	RXG0003	REEL TABLE GEAR	
113	RMBO133	SPRING		163	RJQ112ZA	SPRING	
114	RXQ0099	HEAD SPACER		164	RJQ111ZA	SPRING	
115	REX0094	LEAD WIRE BLOCK		165	RHE5204ZB	SCREW	
116	REX0095	LEAD WIRE BLOCK		166	RJW147ZA	SPRING	
117	XTN2+4F	SCREW		167	RML0037	LEVER	
118	RMRO250	F PEACE		168	XQN2+AF3	SCREW	
119	RJW139ZA	SPRING		169	RMQ0037	FG YOKE	
120	RMA0047A	HEAD BASE		170	RUS609Z	TAPE PRESSURE SPRING	
121	RXR0009	REEL TABLE					
122	RXR0001	REEL TABLE					
123	RXQ0078	MAIN ROD ASS'Y					
124	RJB502Z	LEVER					
125	RME0018-1	SPRING					
126	RME0020	SPRING					
127	RMRO012-2	EJECT ROD (L)					
128	RJW142ZA	SPRING					
129	RXL0007	BRAKE LEVER					
130	XXE2603	SCREW					
131	RHN26002	NUT, ADJUSTMENT					
132	RXP0026	PINCH ROLLER ARM (S)					
132-1	RMBO134	SPRING					
133	XSN2+W4FZ	SCREW					
134	RXP0004	PINCH ROLLER ARM (F)					
134-1	RJW140ZB	SPRING					
135	XTN26+6F	SCREW					
136	RXQ0098	HOUSING BLOCK UNIT					
137	RMK0097	CHASSIS BLOCK UNIT					
138	MMN-6F4RA88	REEL MOTOR					
139	XTN26+7J	SCREW					
140	XTN26+26F	SCREW					
141	RMA0048A	FLYWHEEL PLATE					
142	XTW2+8S	SCREW					
143	RJS11T7ZA	CONNECTOR (11P), J971					
144	RMA0324	BRACKET					
145	RHW21013	WASHER					
146	RXG0009	GEAR ASS'Y					

1 2 3 4 5 6 7 8 9 10

EXPLODED VIEWS

Mechanical parts
(Top view)

A
B
C
D
E
F
G

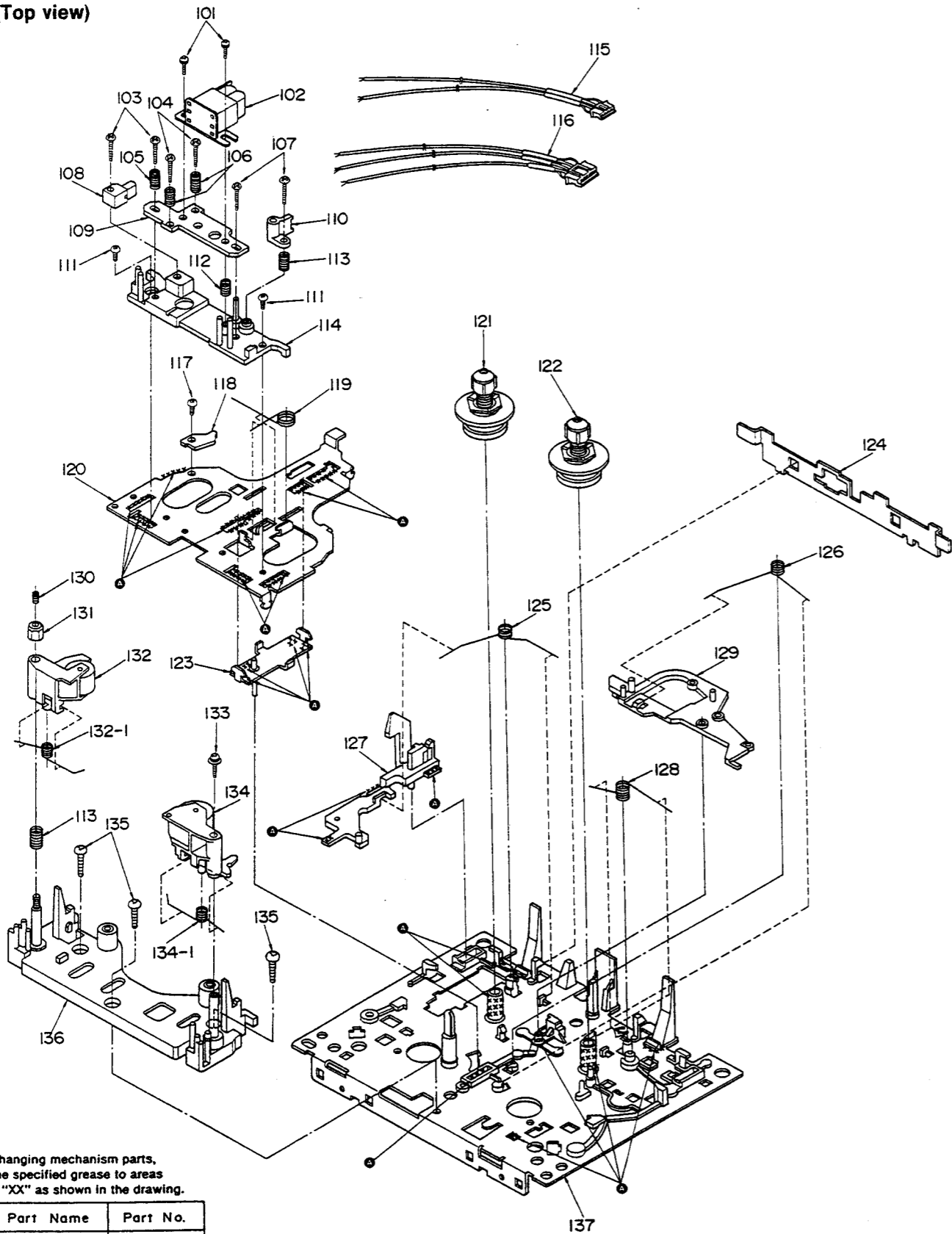

Note:
When changing mechanism parts,
apply the specified grease to areas
marked "XX" as shown in the drawing.

Ref. No.	Part Name	Part No.
Ⓐ	FLOIL AK-152	SZZOL 18
Ⓒ	FLOIL947P	RZZOL 02

(Bottom view)

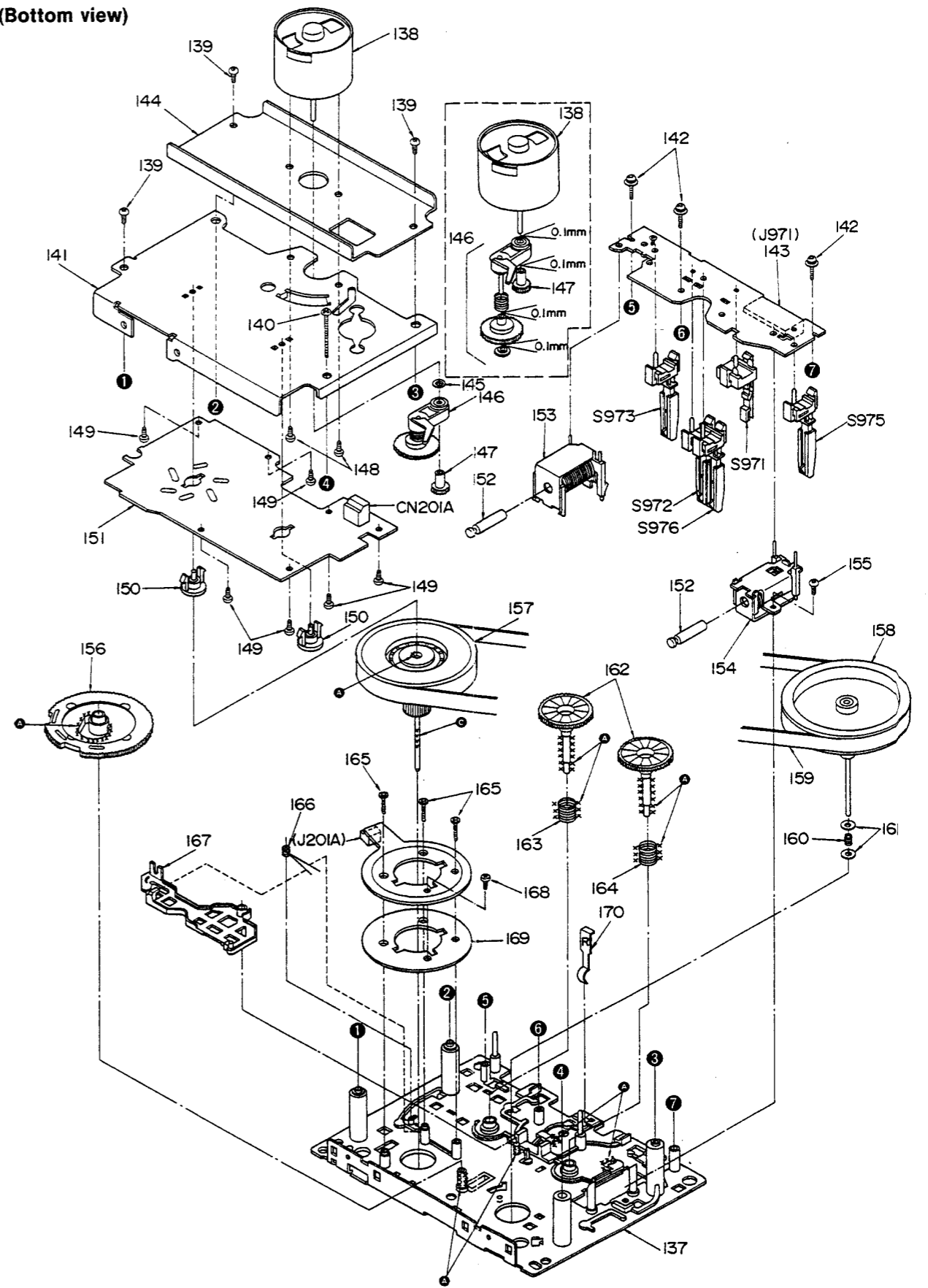

• Cabinet parts

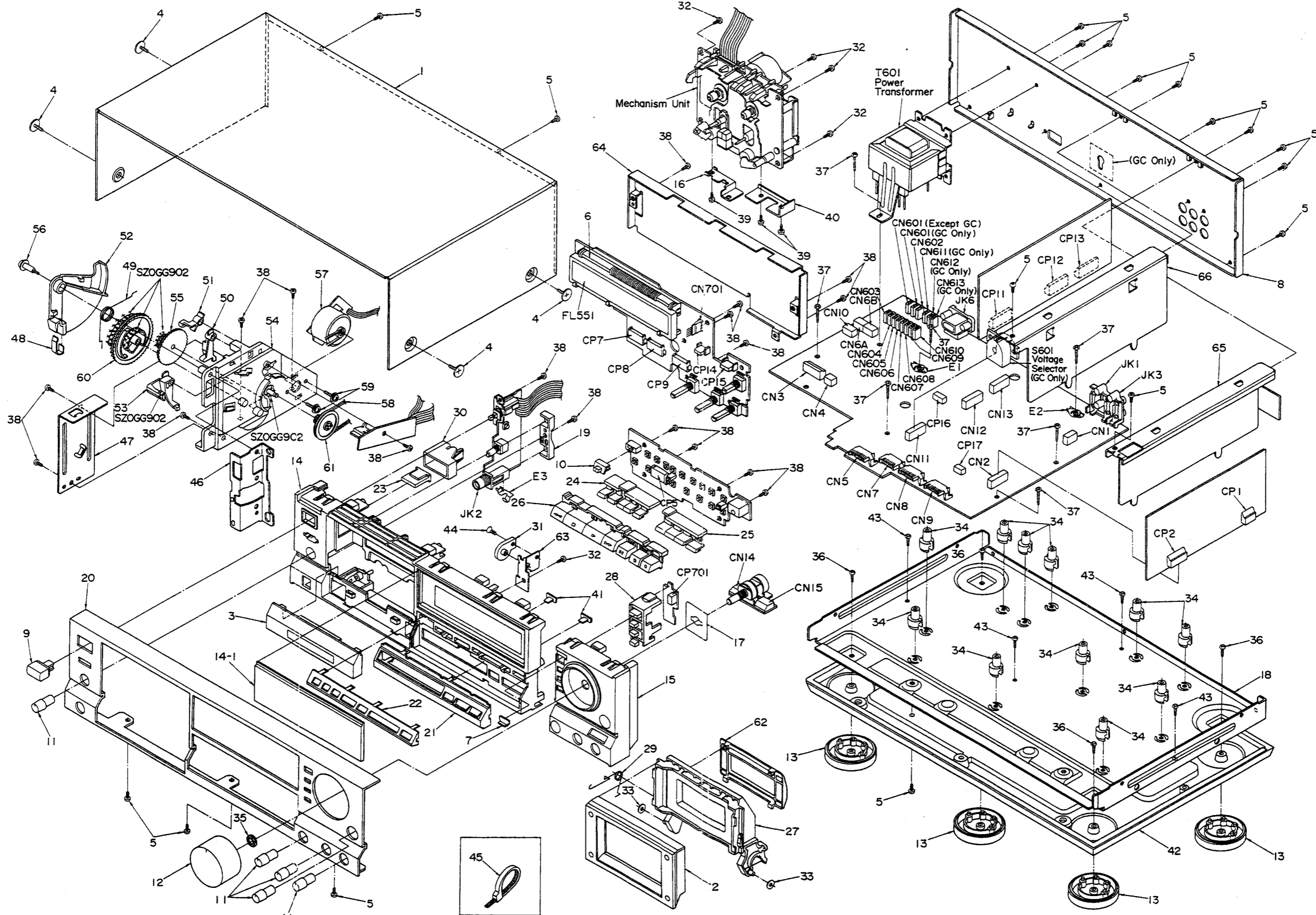

REPLACEMENT PARTS LIST

Notes : * Important safety notice:

Components identified by Δ mark have special characteristics important for safety. When replacing any of these components use only manufacturer's specified parts.

* The parenthesized indications in the Remarks column specify the areas. (Refer to the cover page for area.) Parts without these indications can be used for all areas.

Ref. No.	Part No.	Part Name & Description	Remarks	Ref. No.	Part No.	Part Name & Description	Remarks
		CABINET AND CHASSIS		39	XTB26+4FFZ	SCREW	
1	RFKKS8965E-K	CABINET ASS'Y		40	RSC0076	SHIELD PLATE	
2	RYF0076	CASSETTE LID		41	RGL0030	PANEL LIGHT	
3	RYQ0027	ORNAMENT		42	RKJ0009-1	BOTTOM BOARD	
4	SNE2129-1	SCREW		43	XTB3+10GFZ	SCREW	
5	XTBS3+8JFZ1	SCREW		44	XTS3+8J	SCREW	
6	RMN0021	FL HOLDER		45	SHR301	CLAMPER	
7	RGK0219	BUTTON ORNAMENT		46	RMA0146	LOADING ANGLE	
8	RGR0024A-B	REAR PANEL	(E)	47	RMA0242	ANGLE	
8	RGR0024A-D	REAR PANEL	(EB, GN)	48	RMCO039	BRACKET	
8	RGR0024A-F	REAR PANEL	(EG)	49	RME0039	OPEN SPRING	
8	RGR0024A-E1	REAR PANEL	(PP)	50	RML0110	LEAF SWITCH LEVER (B)	
8	RGR0024B-A1	REAR PANEL	(GC)	51	RML0111	LEAF SWITCH LEVER (C)	
9	RGU0030	BUTTON, POWER		52	RML0112	DRIVE SECTOR LEVER	
10	RGV0022	KNOB, TIMER		53	RML0113	LEAF SWITCH LEVER (A)	
11	RGW0032	KNOB, BALANCE LEVEL		54	RFKNSB755EDK	LOADING BASE ASS'Y	
12	RGW0033	KNOB, REC LEVEL		55	SFUGF01N02	INTERMEDIATE GEAR	
13	RKA0009-1	FOOT		56	SHDD8	SCREW	
14	RFKNSB965EAK	FRONT GRILLE ASS'Y (1)		57	RFKPSB755E-K	EJECT DRIVE MOTOR ASS'Y	
14-1	RKWO038	TRANSPARENT PLATE		58	SMBD7	BELT	
15	RFKNSB965EBK	FRONT GRILLE ASS'Y (2)		59	XYN26+F6	SCREW	
16	RMCO040	BRACKET		60	RDG0080	DRIVE GEAR	
17	RMCO056	SHIELD PLATE		61	RDG0081	PULLEY GEAR	
18	RMKO026-2	CHASSIS		62	RMQ0072	HALF STABILIZER	
19	RMNO022	ORNAMENT		63	RMA0157-1	DAMPER ANGLE	
20	RFKGSB965E-K	FRONT PANEL ASS'Y	(E, EB, EG, GC, GN)	64	RMA0265	PANEL ANGLE	
20	RFKGSB965P-K	FRONT PANEL ASS'Y	(PP)	65	RMA0266	ANGLE (A)	
21	RGK0117	ORNAMENT, BUTTON (A)		66	RMA0267	ANGLE (B)	
22	RGK0118A	ORNAMENT, BUTTON (B)				PACKING MATERIAL	
23	RGU0195	BUTTON, OPEN/CLOSE		P1	RPG0414	CARTON BOX	(E, EB, EG, GC, GN)
24	RGU0131	BUTTON, COUNTER		P1	RPG0586	CARTON BOX	(PP)
25	RGU0132	BUTTON, NOISE REDUCTION		P2	RPN0366A	PAD (A)	
26	RGU0133A	BUTTON, OPERATION		P3	RPN0366B	PAD (B)	
27	RFKNSB755ECK	CASSETTE HOLDER ASS'Y		P4	RPN0366C	PAD (C)	
28	RGU0302	BUTTON, CD DIRECT		P5	RPN0366D	PAD (D)	
29	RME0049	SPRING		P6	SPSD152	PAD, ACCESSORIES	
30	RMR0185	LEVER, OPEN/CLOSE		P7	SPP756	PROTECTION COVER	
31	RFKNSB755CK	DAMPER GEAR ASS'Y				ACCESSORIES	
32	XTB3+10JFZ	SCREW		A1	RFKSSB965E	INSTRUCTION MANUAL ASS'Y	(E)
33	SJD444-1	WASHER		A1	RQT0382-G	INSTRUCTION MANUAL	(EB, GC, GN)
34	SHE187-2	HOLDER		A1	RQT0384-D	INSTRUCTION MANUAL	(EG)
35	SNE4021-1	NUT		A1	RQT0385-P	INSTRUCTION MANUAL	(PP)
36	XTB3+16G	SCREW		A2	RJA0004	POWER CORD	(GC) Δ
37	XTB3+20J	SCREW					
38	XTB3+8JFZ	SCREW					

Ref. No.	Part No.	Part Name & Description	Remarks	Ref. No.	Part No.	Part Name & Description	Remarks
A2	SFDAC05E03	POWER CORD	(E, EG) Δ				
A2	SJA172	POWER CORD	(PP) Δ				
A2	SJA173-1	POWER CORD	(GN) Δ				
A2	SJA193-1	POWER CORD	(EB) Δ				
A3	SJP2249-3	STEREO CONNECTION CABLE					
A4	SJP9215	AC PLUG ADAPTOR	(GC) Δ				

PACKING

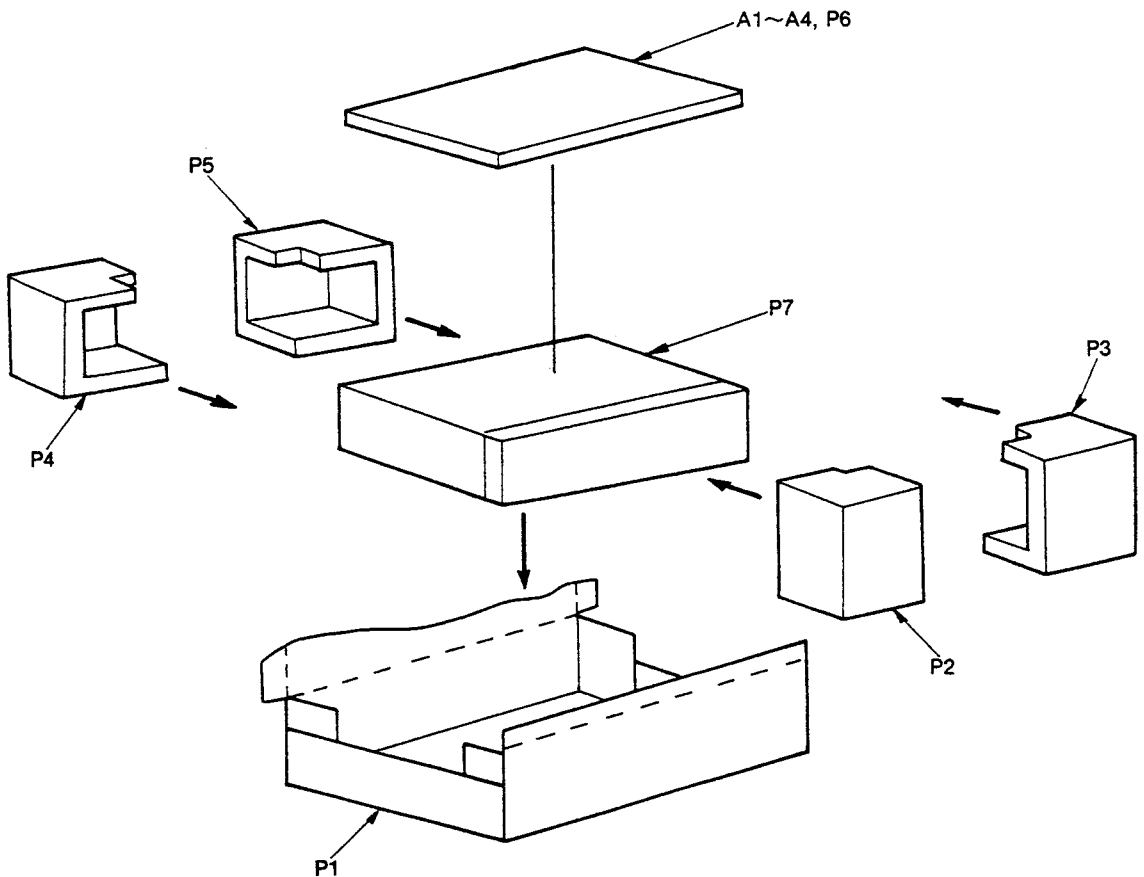

RESISTORS & CAPACITORS

Notes : * Capacity value are in microfarads (μF) unless specified otherwise, P=Pico-farads (pF) F=Farads (F)
 * Resistance values are in ohms, unless specified otherwise, 1K=1,000(OHM) , 1M=1,000k(OHM)

Ref. No.	Part No.	Values & Remarks	Ref. No.	Part No.	Values & Remarks	Ref. No.	Part No.	Values & Remarks
		RESISTORS	R93, 94	ERDS2TJ682T	1/4W 6.8K	R204A	ERJ6GEYJ1R5V	1/10W 1.5
			R95, 96	ERDS2TJ153T	1/4W 15K (E, EB, EG, GC, GN)	R205	ERDS2TJ101T	1/4W 100
R1, 2	ERDS2TJ683T	1/4W 68K	R95, 96	ERDS2TJ223T	1/4W 22K (PP)	R205A	ERJ6GEYJ1R5V	1/10W 1.5
R3-8	ERDS2TJ472T	1/4W 4.7K	R97, 98	ERDS2TJ102T	1/4W 1K	R206	ERDS2TJ393T	1/4W 39K
R9, 10	ERDS2TJ470T	1/4W 47	R99	ERDS2TJ223T	1/4W 22K	R206A	ERJ6GEYJ222V	1/8W 2.2K
R11-14	ERDS2TJ225T	1/4W 2.2M	R100	ERDS2TJ223T	1/4W 22K	R207	ERDS2TJ332T	1/4W 3.3K (PP)
R15, 16	ERDS2TJ123T	1/4W 12K (PP)	R101, 102	ERDS2TJ470T	1/4W 47 (E, EB, EG, GC, GN)	R207	ERDS2TJ472T	1/4W 4.7K (E, EB, EG, GC, GN)
R15, 16	ERDS2TJ153T	1/4W 15K (E, EB, EG, GC, GN)	R101, 102	ERDS2TJ820T	1/4W 82 (PP)	R207A	ERJ6GEYJ1R2V	1/10W 1.8K
R17, 18	ERDS2TJ564T	1/4W 560K	R103, 104	ERDS2TJ102T	1/4W 1K (PP)	R208	ERDS2TJ104T	1/4W 100K
R19, 20	ERDS2TJ103T	1/4W 10K	R103, 104	ERDS2TJ471T	1/4W 470 (E, EB, EG, GC, GN)	R208A	ERJ6GEYJ222V	1/10W 2.2K
R21-26	ERDS2TJ223T	1/4W 22K	R105, 106	ERDS2TJ102T	1/4W 1K	R209	ERDS2TJ102T	1/4W 1K
R27, 28	ERDS2TJ331T	1/4W 330	R107, 108	ERDS2TJ122T	1/4W 1.2K (E, EB, EG, GC, GN)	R209A	ERJ6GEYJ4R7V	1/10W 4.7
R29, 30	ERDS2TJ182T	1/4W 1.8K	R107, 108	ERDS2TJ222T	1/4W 2.2K (PP)	R210	ERDS2TJ473T	1/4W 47K
R31, 32	ERDS2TJ332T	1/4W 3.3K	R109, 110	ERDS2TJ103T	1/4W 10K (PP)	R210A	ERJ6GEYJ4R7V	1/10W 4.7
R33, 34	ERDS2TJ333T	1/4W 33K	R109, 110	ERDS2TJ332T	1/4W 3.3K (E, EB, EG, GC, GN)	R211	ERDS2TJ103T	1/4W 10K
R35, 36	ERDS2TJ101T	1/4W 100	R111, 112	ERDS2TJ562T	1/4W 5.6K	R211A	ERJ6GEYJ4R7V	1/10W 4.7
R37, 38	ERDS2TJ102T	1/4W 1K	R113, 114	ERDS2TJ103T	1/4W 10K (E, EB, EG, GC, GN)	R212	ERDS2TJ823T	1/4W 82K
R39, 40	ERDS2TJ223T	1/4W 22K	R113, 114	ERDS2TJ822T	1/4W 8.2K (PP)	R212A	ERJ6GEYJ152V	1/10W 1.5K
R41-44	ERDS2TJ103T	1/4W 10K	R115, 116	ERDS2TJ222T	1/4W 2.2K (E, EB, EG, GC, GN)	R213-215	ERDS2TJ473T	1/4W 47K
R45, 46	ERDS2TJ101T	1/4W 100	R115, 116	ERDS2TJ272T	1/4W 2.7K (PP)	R213A	ERJ6GEYJ152V	1/10W 1.5K
R47, 48	ERDS2TJ104T	1/4W 100K	R117, 118	ERDS2TJ472T	1/4W 4.7K	R214A	ERJ6GEYJ822V	1/10W 8.2K
R49, 50	ERDS2TJ273T	1/4W 27K	R119-122	ERDS2TJ101T	1/4W 100	R215A	ERJ6GEYJ101V	1/10W 100
R51-54	ERDS2TJ223T	1/4W 22K	R123, 124	ERDS2TJ472T	1/4W 4.7K	R216-218	ERDS2TJ223T	1/4W 22K
R55, 56	ERDS2TJ562T	1/4W 5.6K	R125-128	ERDS2TJ101T	1/4W 100	R216A	ERJ6GEYJ222V	1/8W 2.2K
R57, 58	ERDS2TJ333T	1/4W 33K	R129-132	ERDS2TJ152T	1/4W 1.5K	R301	ERDS2TJ1R0T	1/4W 1.0
R59, 60	ERDS2TJ363T	1/4W 36K	R133-136	ERDS2TJ102T	1/4W 1K	R302, 303	ERDS2TJ183T	1/4W 18K
R61, 62	ERDS2TJ103T	1/4W 10K	R137	ERDS2TJ392T	1/4W 3.9K	R304, 305	ERDS2TJ100T	1/4W 10
R63, 64	ERDS2TJ223T	1/4W 22K	R138	ERDS2TJ182T	1/4W 1.8K	R306	ERDS2TJ563T	1/4W 56K (PP)
R65, 66	ERDS2TJ153T	1/4W 15K	R139, 140	ERDS2TJ104T	1/4W 100K	R307	ERDS2TJ472T	1/4W 4.7K
R67, 68	ERDS2TJ473T	1/4W 47K	R141, 142	ERDS2TJ102T	1/4W 1K	R308	ERDS2TJ332T	1/4W 3.3K
R69	ERDS2TJ562T	1/4W 5.6K	R143, 144	ERDS2TJ273T	1/4W 27K	R309	ERDS2TJ272T	1/4W 2.7K
R70	ERDS2TJ333T	1/4W 33K	R145, 146	ERDS2TJ392T	1/4W 3.9K	R310	ERDS2TJ182	1/4W 1.8 (PP)
R71	ERDS2TJ682T	1/4W 6.8K	R151, 152	ERDS2TJ223T	1/4W 22K	R310	ERDS2TJ222T	1/4W 2.2K (E, EB, EG, GC, GN)
R72	ERDS2TJ223T	1/4W 22K	R155, 156	ERDS2TJ104T	1/4W 100K	R313, 314	ERDS2TJ124T	1/4W 10K (PP)
R73, 74	ERDS2TJ821T	1/4W 820	R157, 158	ERDS2TJ562T	1/4W 5.6K	R313, 314	ERDS2TJ154T	1/4W 10K (E, EB, EG, GC, GN)
R75, 76	ERDS2TJ103T	1/4W 10K	R159-162	ERDS2TJ101T	1/4W 100	R315, 316	ERDS2TJ273T	1/4W 27K (E, EB, EG, GC, GN)
R77, 78	ERDS2TJ391T	1/4W 390	R165, 166	ERDS2TJ104T	1/4W 100K	R315, 316	ERDS2TJ333T	1/4W 33K (PP)
R79	ERDS2TJ562T	1/4W 5.6K	R201, 202	ERDS2TJ183T	1/4W 18K	R318	ERDS2TJ152T	1/4W 1.5K
R80	ERDS2TJ332T	1/4W 3.3K	R201A	ERJ6GEYJ273V	1/10W 27K	R319	ERDS2TJ102T	1/4W 1K
R81	ERDS2TJ272T	1/4W 2.7K	R202A	ERJ6GEYJ683V	1/10W 68K	R320	ERDS2TJ332T	1/4W 3.3K
R82	ERDS2TJ202	1/4W 2K	R203A	ERJ6GEYJ1R5V	1/10W 1.5	R321	ERDS2TJ473T	1/4W 47K
R85, 86	ERDS2TJ223T	1/4W 22K (PP)	R204	ERDS2TJ821T	1/4W 820	R322	ERDS2TJ102T	1/4W 1K
R85, 86	ERDS2TJ683T	1/4W 68K (E, EB, EG, GC, GN)				R323	ERDS1FVJ121T	1/2W 20 (E, EG, GC) Δ
R87, 88	ERDS2TJ222T	1/4W 2.2K				R323	ERDS1FJ390	1/2W 39 (E, EB, GN) Δ
R89, 90	ERDS2TJ334T	1/4W 330K						
R91, 92	ERDS2TJ273T	1/4W 27K						

Ref. No.	Part No.	Values & Remarks	Ref. No.	Part No.	Values & Remarks	Ref. No.	Part No.	Values & Remarks
R323	ERDS1FJ470	1/2W 47 (PP) △	R604	ERDS2TJ472T	1/4W 4.7K	R670	ERDS2TJ223T	1/4W 22K
R324, 325	ERDS1FJ390	1/2W 39 (EB, GN) △	R605, 606	ERDS1FVJ100T	1/2W 10 (PP, E, EG, GC) △	R675	ERDS2TJ102T	1/4W 1K
R390	ERDS2TJ182	1/4W 1.8K (PP)				R676	ERDS2TJ103T	1/4W 10K
R391	ERDS1FJ390	1/2W 39 (PP) △	R605, 606	ERD2FCVG100T	1/4W 10 (EB, GN)	R680, 681	ERDS2TJ223T	1/4W 22K
R401-404	ERDS2TJ684T	1/4W 680K	R607, 608	ERDS2TJ561T	1/4W 560	R682	ERDS2TJ473T	1/4W 47K
R405, 406	ERDS2TJ182T	1/4W 1.8K	R609, 610	ERDS2TJ152T	1/4W 1.5K	R685	ERDS1FVJ220T	1/2W 22 (PP, E, EG, GC) △
R407, 408	ERDS2TJ302T	1/4W 3K	R611	ERDS2TJ472T	1/4W 4.7K			
R409, 410	ERDS2TJ431T	1/4W 430	R612	ERDS2TJ103T	1/4W 10K	R690, 691	ERDS2TJ473T	1/4W 47K
R411, 412	ERDS2TJ362T	1/4W 3.6K	R613	ERDS2TJ222T	1/4W 2.2K	R695	ERDS2TJ103T	1/4W 10K
R413, 414	ERDS2TJ682T	1/4W 6.8K	R614	ERDS1FVJ270T	1/2W 27 (PP, E, EG, GC) △	R699	ERDS2TJ123T	1/4W 12K
R415, 416	ERDS2TJ681T	1/4W 680				R701	ERDS2TJ821T	1/4W 820
R417	ERDS2TJ104T	1/4W 100K	R614	ERD2FCVG270T	1/4W 27 (EB, GN) △	R702	ERDS2TJ102T	1/4W 1K
R419, 420	ERDS2TJ183T	1/4W 18K (E, EB, EG, GC, GN)	R615	ERDS1FVJ220T	1/2W 22 (PP, E, EG, GC) △	R703	ERDS2TJ122T	1/4W 1.2K
						R704	ERDS2TJ152T	1/4W 1.5K
R419, 420	ERDS2TJ822T	1/4W 8.2K (PP)	R615	ERD2FCVG270T	1/4W 27 (EB, GN) △	R705	ERDS2TJ182T	1/4W 1.8K
R421, 422	ERDS2TJ272T	1/4W 2.7K	R616	ERDS2TJ222T	1/4W 2.2K	R706	ERDS2TJ222T	1/4W 2.2K
R423, 424	ERDS2TJ512T	1/4W 5.1K	R617	ERDS2TJ1R0T	1/4W 1.0	R707	ERDS2TJ332T	1/4W 3.3K
R425	ERDS2TJ103T	1/4W 10K	R619	ERDS2TJ391T	1/4W 390	R708	ERDS2TJ472T	1/4W 4.7K
R427	ERDS2TJ822T	1/4W 8.2K	R622	ERDS1FVJ3R3T	1/2W 3.3 △	R709	ERDS2TJ682T	1/4W 6.8K
R429, 430	ERDS2TJ822T	1/4W 8.2K	R623	ERDS2TJ102T	1/4W 1K	R710	ERDS2TJ123T	1/4W 12K
R431, 432	ERDS2TJ223T	1/4W 22K	R625	ERDS1FVJ120T	1/2W 12 △	R711	ERDS2TJ223T	1/4W 22K
R433, 434	ERDS2TJ471T	1/4W 470	R626	ERDS2TJ102T	1/4W 1K	R712	ERDS2TJ821T	1/4W 820
R440	ERDS2TJ333T	1/4W 33K	R627, 628	ERDS2TJ222T	1/4W 2.2K	R713	ERDS2TJ102T	1/4W 1K
R451, 452	ERDS2TJ162T	1/4W 1.6K	R631, 632	ERDS2TJ222T	1/4W 2.2K	R714	ERDS2TJ122T	1/4W 1.2K
R453, 454	ERDS2TJ431T	1/4W 430	R633	ERDS2TJ121T	1/4W 120 (PP, E, EG, GC)	R715	ERDS2TJ152T	1/4W 1.5K
R457, 458	ERDS2TJ682T	1/4W 6.8K				R716	ERDS2TJ182T	1/4W 1.8K
R459, 460	ERDS2TJ681T	1/4W 680	R633	ERD2FCVG270T	1/4W 27 (EB, GN)	R717	ERDS2TJ181T	1/4W 180
R461	ERDS2TJ104T	1/4W 100K	R634-637	ERDS2TJ222T	1/4W 2.2K	R718	ERDS2TJ331T	1/4W 330
R463, 464	ERDS2TJ183T	1/4W 18K	R638, 639	ERDS2TJ121T	1/4W 120 (PP, E, EG, GC)	R719, 720	ERDS2TJ180	1/4W 18
R465, 466	ERDS2TJ222T	1/4W 2.2K				R721, 722	ERDS2TJ330T	1/4W 33
R467, 468	ERDS2TJ103T	1/4W 10K	R638, 639	ERD2FCVG270T	1/4W 27 (EB, GN)	R723, 724	ERDS2TJ100T	1/4W 10
R497, 498	ERDS2TJ222T	1/4W 2.2K	R640-643	ERDS2TJ222T	1/4W 2.2K	R725, 726	ERDS2TJ102T	1/4W 1K
R551, 552	ERDS2TJ104T	1/4W 100K	R644	ERDS2TJ121T	1/4W 120 (PP, E, EG, GC)	R727, 728	ERDS2TJ332T	1/4W 3.3K
R553, 554	ERDS2TJ204T	1/4W 200K				R730	ERDS2TJ472T	1/4W 4.7K
R555, 556	ERDS2TJ823T	1/4W 82K	R644	ERD2FCVG270T	1/4W 27 (EB, GN)	R803, 804	ERDS2TJ223T	1/4W 22K
R557, 558	ERDS2TJ220T	1/4W 22	R645-647	ERQ16NKR15E	1/6W 0.15 (EB, GN)	R805, 806	ERDS2TJ243	1/4W 24K
R559, 560	ERDS2TJ272T	1/4W 2.7K	R650, 651	ERDS2TJ472T	1/4W 4.7K (EB, GN)	R807, 808	ERDS2TJ622	1/4W 6.2K
R561	ERDS2TJ102T	1/4W 1K	R652, 653	ERDS2TJ222T	1/4W 2.2K (EB, GN)	R809, 810	ERDS2TJ913T	1/4W 91K
R562	ERDS2TJ471T	1/4W 470	R654, 655	ERDS2TJ332T	1/4W 3.3K (EB, GN)	R811, 812	ERDS2TJ472T	1/4W 4.7K
R563, 564	ERDS2TJ103T	1/4W 10K	R657	ERDS2TJ332T	1/4W 3.3K	R813, 814	ERDS2TJ333T	1/4W 33K
R565	ERDS2TJ105T	1/4W 1M	R658	ERDS2TJ473T	1/4W 47K	R815, 816	ERDS2TJ682T	1/4W 6.8K
R569, 570	ERDS2TJ101T	1/4W 100	R659	ERDS1FVJ330T	1/2W 33 (PP, E, EG, GC) △	R817, 818	ERDS2TJ333T	1/4W 33K
R571	ERDS2TJ152T	1/4W 1.5K				R819, 820	ERDS2TJ183T	1/4W 18K
R572	ERDS2TJ102T	1/4W 1K	R659	ERD2FCVG330T	1/4W 33 (EB, GN) △	R821, 822	ERDS2TJ182T	1/4W 1.8K
R573	ERDS2TJ270T	1/4W 27	R660	ERD2FCVG100T	1/4W 10 △	R823, 824	ERDS2TJ123T	1/4W 12K
R574	ERDS2TJ220T	1/4W 22	R661	ERDS2TJ472T	1/4W 4.7K	R825, 826	ERDS2TJ112	1/4W 1.1K
R575-578	ERDS2TJ331T	1/4W 330	R662, 663	ERDS1FVJ100T	1/2W 10 (PP, E, EG, GC)	R827, 828	ERDS2TJ225T	1/4W 2.2M
R581, 582	ERDS2TJ822T	1/4W 8.2K				R829, 830	ERDS2TJ332T	1/4W 3.3K (PP)
R583, 584	ERDS2TJ103T	1/4W 10K	R662, 663	ERD2FCVG100T	1/4W 10 (EB, GN)	R829, 830	ERDS2TJ392T	1/4W 3.9K (E, EB, EG, GC, GN)
R585	ERDS2TJ223T	1/4W 22K	R664-667	ERDS2TJ101T	1/4W 100 (EB, GN)			
R601, 602	ERDS2TJ472T	1/4W 4.7K	R668	ERDS2TJ563T	1/4W 56K (EB, GN)	R831	ERDS2TJ102T	1/4W 1K
R603	ERDS2TJ103T	1/4W 10K	R669	ERDS2TJ472T	1/4W 4.7K	R853, 854	ERDS2TJ362T	1/4W 3.6K

Ref. No.	Part No.	Values & Remarks	Ref. No.	Part No.	Values & Remarks	Ref. No.	Part No.	Values & Remarks
R855, 856	ERDS2TJ243	1/4W 24K	R961, 962	ERDS2TJ561T	1/4W 560 (E, EB, EG, GC, GN)	C27, 28	ECBT1H390J5	50V 39P
R857, 858	ERDS2TJ622	1/4W 6.2K				C29, 30	ECA1EPXS100	25V 10U
R859, 860	ERDS2TJ913T	1/4W 91K	R963	ERDS2TJ223T	1/4W 22K	C31, 32	ECQB1H122JZ3	50V 1200P
R861, 862	ERDS2TJ472T	1/4W 4.7K	R964	ERDS2TJ105T	1/4W 1M	C33, 34	ECQB1H103JZ3	50V 0.01U
R863, 864	ERDS2TJ333T	1/4W 33K	R965	ERDS2TJ471T	1/4W 470	C35	ECQB1H332JZ3	50V 3300P
R865, 866	ERDS2TJ682T	1/4W 6.8K	R966, 967	ERDS2TJ103T	1/4W 10K	C36	ECQB1H273JZ3	50V 0.027U
R867, 868	ERDS2TJ333T	1/4W 33K	R970	ERDS2TJ222T	1/4W 2.2K	C37, 38	ECA1EPXS100	25V 10U
R869, 870	ERDS2TJ183T	1/4W 18K	R971	ERDS2TJ332T	1/4W 3.3K	C39-42	ECA1HPXS100	50V 10U
R871, 872	ERDS2TJ182T	1/4W 1.8K	R971A	ERDS2TJ271T	1/4W 270	C43, 44	ECBT1H101KB5	50V 100P
R873, 874	ERDS2TJ123T	1/4W 12K	R972	ERDS2TJ472T	1/4W 4.7K	C45, 46	ECBT1H221KB	50V 220P
R875, 876	ERDS2TJ112	1/4W 1.1K	R972A	ERDS2TJ183T	1/4W 18K	C47, 48	ECA1HPXSR33B	50V 0.33U
R877, 878	ERDS2TJ225T	1/4W 2.2M	R973	ERDS2TJ682T	1/4W 6.8K	C49, 50	ECQB1H272JZ3	50V 2700P (PP)
R879, 880	ERDS2TJ431T	1/4W 430	R973A	ERDS2TJ271T	1/4W 270	C49, 50	ECQB1H682JZ3	50V 6800P (E, EB, EG, GC, GN)
R881	ERDS2TJ102T	1/4W 1K	R974	ERDS2TJ123T	1/4W 12K			
R901	ERDS2TJ472T	1/4W 4.7K	R974A	ERDS2TJ183T	1/4W 18K	C51, 52	ECQB1H183JZ3	50V 0.018U
R902-904	ERDS2TJ103T	1/4W 10K	R975	ERDS2TJ223T	1/4W 22K	C53, 54	ECQB1H223JZ3	50V 0.022U (PP)
R905	ERDS2TJ821T	1/4W 820	R977	ERDS2TJ473T	1/4W 47K	C53, 54	ECQB1H472JZ3	50V 4700P (E, EB, EG, GC, GN)
R906	ERDS2TJ223T	1/4W 22K	R979, 980	ERDS2TJ123T	1/4W 12K			
R907, 908	ERDS2TJ103T	1/4W 10K	R981-983	ERDS2TJ472T	1/4W 4.7K	C55, 56	ECQB1H392JZ3	50V 3900P (PP)
R909	ERDS2TJ472T	1/4W 4.7K	R984	ERDS2TJ223T	1/4W 22K	C55, 56	ECQB1H822JZ3	50V 8200P (E, EB, EG, GC, GN)
R911, 912	ERDS2TJ225T	1/4W 2.2M	R985	ERDS2TJ103T	1/4W 10K			
R913, 914	ERDS2TJ472T	1/4W 4.7K	R986	ERDS2TJ332T	1/4W 3.3K	C57, 58	ECQB1H223JZ3	50V 0.022U (PP)
R915, 916	ERDS2TJ103T	1/4W 10K	R987	ERDS2TJ103T	1/4W 10K	C57, 58	ECQB1H273JZ3	50V 0.027U (E, EB, EG, GC, GN)
R917, 918	ERDS2TJ563T	1/4W 56K	R988	ERDS2TJ223T	1/4W 22K			
R919, 920	ERDS2TJ105T	1/4W 1M	R989	ERDS2TJ103T	1/4W 10K	C59, 60	ECQB1H183JZ3	50V 0.018U
R922	ERDS2TJ821T	1/4W 820	R991	ERDS2TJ222T	1/4W 2.2K	C61, 62	ECQV1H473JZ3	50V 0.047U (PP)
R924	ERDS2TJ123T	1/4W 12K	R994, 995	ERDS2TJ103T	1/4W 10K	C61, 62	ECQV1H683JZ3	50V 0.68U (E, EB, EG, GC, GN)
R935	ERDS2TJ103T	1/4W 10K	R996	ERDS2TJ223T	1/4W 22K			
R937	ERDS2TJ683T	1/4W 68K	R997	ERDS2TJ222T	1/4W 2.2K	C63, 64	ECQB1H183JZ3	50V 0.018U (PP)
R938, 939	ERDS2TJ472T	1/4W 4.7K	R998	ERDS2TJ103T	1/4W 10K	C63, 64	ECQB1H333JZ3	50V 0.033U (E, EB, EG, GC, GN)
R940	ERDS2TJ103T	1/4W 10K (PP, E, EG, GC)	R999	ERDS2TJ272T	1/4W 2.7K			
R941	ERDS2TJ821T	1/4W 820				C65, 66	ECA1EPXS220B	25V 22U
R942	ERDS2TJ223T	1/4W 22K				C67, 68	ECQP1101JZ3	50V 100P (PP)
R943	ERG1SJ180E	1W 18	J201-206	ERJ6GEY0R00V	CHIP JUMPER	C67, 68	ECQP1121JZ	50V 100P (E, EB, EG, GC, GN)
R944	ERG1SJ150E	1W 15						
R945	ERDS2TJ223T	1/4W 22K			CAPACITORS	C69, 70	ECQB1H122JZ3	50V 1200P
R946	ERDS2TJ821T	1/4W 820				C75, 76	ECA1HPXS100	50V 10U
R947	ERDS2TJ223T	1/4W 22K	C1, 2	ECBT1H151KB5	50V 150P (E, EB, EG, GC, GN)	C79, 80	ECBT1H470J5	50V 47P
R948	ERDS2TJ821T	1/4W 820				C201	ECUV1E153MB	25V 0.05U
R949	ERDS2TJ103T	1/4W 10K	C3, 4	ECQB1H183JZ3	50V 0.018U	C202	ECUV1E104KB	25V 0.1U
R950	ERDS2TJ182T	1/4W 1.8K	C5, 6	ECQB1H562JZ3	50V 5600P	C203, 204	ECEV1CA100R	16V 0U
R951	ERDS2TJ682T	1/4W 6.8K	C7, 8	ECA0JPXS471B	6.3V 470U	C205, C206	ECUV1E104KB	25V 0.1U
R952	ERDS2TJ104T	1/4W 100K	C9, 10	ECQB1H152JZ3	50V 1500P	C209-211	ECEV1EN100R	25V 0U
R953	ERDS2TJ393T	1/4W 39K	C11, 12	ECBT1H470J5	50V 47P	C212-214	ECUV1H1032FN	50V 0.01U
R954	ERDS2TJ103T	1/4W 10K	C13, 14	ECQB1H103JZ3	50V 0.01U (E, EB, EG, GC, GN)	C215	ECUV1H472KB	50V 470P
R955	ERDS2TJ392T	1/4W 3.9K				C216	ECUV1H562KBN	25V 560P
R956	ERDS2TJ272T	1/4W 2.7K	C13, 14	ECQB1H273JZ3	50V 0.027U (PP)	C217-219	ECUV1E104KB	25V 0.1U
R957	ERDS2TJ333T	1/4W 33K	C15, 16	ECQB1H123JZ	50V 0.012U	C301	ECQP1153JZ	50V 0.05U (E, EB, EG, GC, GN)
R958, 959	ERDS2TJ103T	1/4W 10K	C17, 18	ECA1EPXS100	25V 10U			
R960	ERDS2TJ152T	1/4W 1.5K	C19, 20	ECA1EPXS220B	25V 22U	C301	ECQP1822JZ3	50V 820P (PP)
R961, 962	ERDS2TJ391T	1/4W 390 (PP)	C23-26	ECA1EPXS100	25V 10U	C302	ECEA1EK4R7B	25V 4.7U
						C303	ECKR1H392KB5	50V 390P

Ref. No.	Part No.	Values & Remarks	Ref. No.	Part No.	Values & Remarks	Ref. No.	Part No.	Values & Remarks
C304, 305	ECKR1H222KB5	50V 2200P	C567, 568	ECEA1VK100B	35V 10U	C905, 906	ECEA1CN100SB	16V 10U
C306	ECKT1H682KB	50V 6800P	C601, 602	ECKD2H682PE	500V 6800P	C907	ECKR1H103ZF5	50V 0.01U
C310	ECKR1H103ZF5	50V 0.01U	C603, 604	ECA1EPXS102E	25V 1000U	C908	ECEA1EK4R7B	25V 4.7U
C315, 316	ECBT1H470J5	50V 47P (PP)	C605	ECEA1EU222E	25V 2200U	C909	ECEA1HK010B	50V 1U
C315, 316	ECBT1H561KB5	50V 560P (E, EB, EG GC, GN)	C606-608	ECKR1H103ZF5	50V 0.01U	C910	ECEA1HU220B	50V 22U
C317, 318	ECBT1H121KB5	50V 120P	C609, 610	ECBT1E103ZF5	25V 0.01U	C913, 914	ECQV1H184JZ3	50V 0.18U
C319, 320	ECQB1H183JZ	50V 0.018U (PP)	C611, 612	ECKR1H103ZF5	50V 0.01U	C930	ECEA1HK4R7B	50V 4.7U
C319, 320	ECQB1H333JZ	50V 0.033U (E, EB, EG, GC, GN)	C613, 614	ECBT1E103ZF5	25V 0.01U	C931, 932	ECBT1E103ZF5	25V 0.01U
C321, 322	ECQB1H223JZ3	50V 0.022U	C615-618	ECKR1H103ZF5	50V 0.01U	C933, 934	ECBT1C472MRS	16V 4700P
C323, 324	ECQB1H103JZ3	50V 0.01U	C619, 620	ECBT1E103ZF5	25V 0.01U	C935	ECBT1E103ZF5	25V 0.01U
C325, 326	ECBT1H471KB5	50V 470P (PP)	C621, 622	ECA1CPXS221	16V 220U	C936	ECEA1HU100B	50V 10U
C325, 326	ECBT1H681KB5	50V 680P (E, EB, EG, GC, GN)	C625	ECKR1H103ZF5	50V 0.01U			
C328	ECBT1H102KB5	50V 1000P (E, EB, EG, GC, GN)	C626	ECEA0JU222B	6.3V 2200U			
C328	ECBT1H680J5	50V 68P (PP)	C627-638	ECA1APXS101	10V 100U			
C329	ECA1HPXS100	50V 10U	C641, 642	ECA1EPXS102E	25V 1000U			
C330	ECKR1H103ZF5	50V 0.01U	C643	ECEA1HU221B	50V 220U			
C401, 402	ECKT1H122KB	50V 1200P	C644	ECEA1HK010B	50V 1U (EB, GN)			
C403, 404	ECKD1H152KB	50V 1500P	C646, 647	ECBT1E103ZF5	25V 0.01U			
C405, 406	ECKR1H681KB5	50V 680P	C648	ECEA1EK100B	25V 10U			
C407, 408	ECQB1H472JZ3	50V 4700P	C649	ECKR1H103ZF5	50V 0.01U			
C409, 410	ECQV1H474JZ3	50V 0.47U	C690	ECEA1HK2R2B	50V 2.2U			
C411, 412	ECQV1H154JZ	50V 0.15U	C691	ECKR1H103ZF5	50V 0.01U			
C413, 414	ECQB1H153JZ3	50V 0.015U	C701	ECBT1E223ZF5	25V 0.022U			
C415, 416	ECQV1H224JZ3	50V 0.22U	C702, 703	ECEA1HK010B	50V 1U			
C417, 418	ECQV1H683JZ3	50V 0.68U	C801, 802	ECA1EPXS220B	25V 22U			
C419, 420	ECQV1H473JZ3	50V 0.047U	C803, 804	ECQB1H153JZ3	50V 0.015U			
C421, 422	ECQB1H682JZ3	50V 6800P	C805, 806	ECKR1H331KB5	50V 330P			
C423, 424	ECQB1H103JZ3	50V 0.01U	C807, 808	ECEA1AN220SB	10V 22U			
C425, 426	ECA1HPXS4R7B	50V 4.7U	C809-812	ECQV1H104JZ3	50V 0.1U			
C451, 452	ECKR1H681KB5	50V 680P	C813-816	ECQB1H332JZ3	50V 3300P			
C453, 454	ECQB1H472JZ3	50V 4700P	C817, 818	ECKR1H331KB5	50V 330P			
C455, 456	ECQV1H474JZ3	50V 0.47U	C819, 820	ECQV1H184JZ3	50V 0.18U			
C457, 458	ECQV1H154JZ	50V 0.15U	C821, 822	ECQB1H183JZ3	50V 0.018U			
C459, 460	ECQB1H153JZ3	50V 0.015U	C823, 824	ECA1EPXS220B	25V 22U			
C461, 462	ECQV1H224JZ3	50V 0.22U	C825, 826	ECBT1C182MRS	16V 1800P			
C463, 464	ECQV1H683JZ3	50V 0.68U	C827, 828	ECA1HPXS3R3	50V 3.3U			
C465, 466	ECQV1H473JZ3	50V 0.047U	C851, 852	ECA1EPXS220B	25V 22U			
C467, 468	ECQB1H682JZ3	50V 6800P	C853, 854	ECQB1H153JZ3	50V 0.015U			
C469, 470	ECQB1H103JZ3	50V 0.01U	C855, 856	ECKR1H331KB5	50V 330P			
C471, 472	ECA1HPXS4R7B	50V 4.7U	C857, 858	ECEA1AN220SB	10V 22U			
C551, 552	ECQV1H333JZ3	50V 0.033U	C859-862	ECQV1H104JZ3	50V 0.1U			
C553, 554	ECEA0JKS101B	6.3V 100U	C863-866	ECQB1H332JZ3	50V 3300P			
C555	ECBT1E103ZF5	25V 0.01U	C867, 868	ECKR1H331KB5	50V 330P			
C556	ECEA1CK100B	16V 10U	C869, 870	ECQV1H184JZ3	50V 0.18U			
C557	ECEA1EK4R7B	25V 4.7U	C871, 872	ECQB1H183JZ3	50V 0.018U			
C558	ECEA1HK010B	50V 1U	C873, 874	ECA1EPXS220B	25V 22U			
C559-561	ECBT1E103ZF5	25V 0.01U	C875, 876	ECBT1C182MRS	16V 1800P			
C563, 564	ECEA0JKS101B	6.3V 100U	C877, 878	ECA1HPXS3R3	50V 3.3U			
			C901	ECQB1H822JZ3	50V 8200P			
			C902	ECEA1CK100B	16V 10U			
			C903	ECBT1H470J5	50V 47P			
			C904	ECEA1HK010B	50V 1U			

Service Manual

Cassette Deck

RS-B965

Supplement

Dolby NR-Equipped
Stereo Cassette Deck

Colour
(K)... Black Type

DOLBY B-C NR HX PRO

* HX Pro headroom extension originated by Bang Olufsen and manufactured under license from Dolby Laboratories Licensing Corporation. "DOLBY", the double-D symbol, and "HX PRO" are trademarks of Dolby Laboratories Licensing Corporation.

Please file and use this supplement manual together with the service manual for Model No. RS-B965, Order No. AD9002037C8 (E, EB, EG, GC, GN), AD9004084C1 (PP) and AD9102038A2 (EP).

Suffix for Model No.	Area	Colour
(PP)	U.S.A./Canada.	(K)
(E)	Continental Europe.	
(EB)	Great Britain.	
(EG)	F.R. Germany/Italy.	
(GC)	Asia/Latin America, Middle Near East/Africa.	
(GN)	Oceania.	
(EP)	Poland.	

We inform you that we have changed the following zener diode in order to improve the takeup torque performance.

CHANGES

CHANGE IN REPLACEMENT PARTS LIST

Ref. No.	Change of Part No.		Part Name & Description	Remarks
	ORIGINAL	NEW		
DIODE (S)				
D625	MA4051MTA	MTZJ4R3BTA	Zener Diode	Change

CHANGE OF SUFFIX NO.

"D" → "E" EX: FP2J **D** 01126 → Suffix **E**

SCHEMATIC DIAGRAM (on page 33)

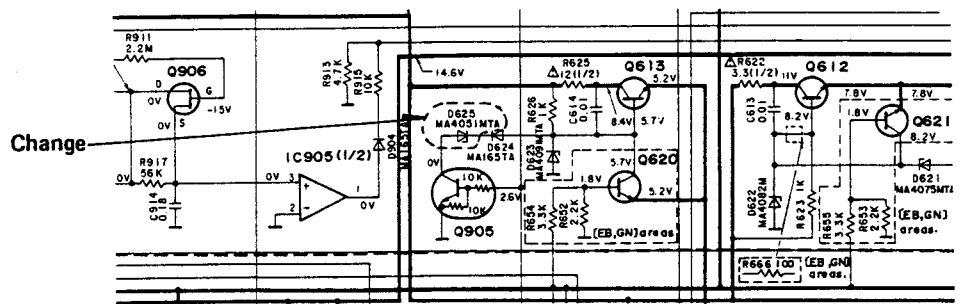



Gesamtfrequenzgang

1. Legen Sie das normale Leertestband (QZZCRA) ein und stellen das Gerät auf Aufnahme-/Pause-Betrieb.
2. Geben Sie über einen Lautstärkeregler ein Bezugseingabesignal (1 kHz, -24 dB) ein.
3. Stellen Sie das Signal auf 20 dB und justieren die Frequenz von 50 Hz~10 kHz.
4. Nehmen Sie das Wobbelsignal auf.
5. Geben Sie das aufgenommene Signal wieder und achten darauf, daß dieses sich im Vergleich zur Bazugsfrequenz (1 kHz) in dem in **Abb. 8** aufgezeichneten Bereich befindet.
6. Sollte das Signal nicht im Normbereich liegen, justieren Sie **VR301** (L-K) und **VR302** (R-K), so daß der Frequenzpegel mit der Norm übereinstimmt.
7. Wiederholen Sie die Schritte 2~6 und verwenden das CrO₂ Band (QZZCRX) und das Metallband (QZZCRZ). Der Frequenzbereich wird auf 12.5 kHz (50 Hz~12.5 kHz) angehoben.
8. Achten Sie darauf, daß sich der Frequenzpegel in dem in **Abb. 9** aufgezeigten Bereich befindet.

Löschstromeinstellung

1. Die leere Metallband-Prüfkassette (QZZCRZ) einsetzen und das Gerät auf Aufnahmepause schalten.
2. **VR304** so einstellen, daß der Ausgang zwischen **TP6** und GND dem Sollwert entspricht.

dbx Takteinstellung

1. Den Rauschunterdrückungs-Schalter auf dbx stellen.
2. Den Abschnitt für Verstärkungseinstellung (315 Hz, 0 dB) des Prüfbandes (QZZCFM) wiedergeben.
3. Einen Gleichstrom-Voltmeter zwischen **TP1** (**TP4**) und **TP2** (**TP3**) anschließen.
4. **VR501** (**VR502**) so einstellen, daß der Ausgang dem Sollwert entspricht.

HX-PRO Einstellung

1. Die leere Metallband-Prüfkassette (QZZCRZ) einsetzen und das Gerät auf Aufnahmepause schalten.
2. Einen Gleichstrom-Voltmeter zwischen **TP15** (linker Kanal) und GND sowie zwischen **TP16** (rechter Kanal) und GND anschließen.
3. **L303** (linker Kanal) und **L302** (rechter Kanal) so einstellen, daß der Mini malwert ist.

REC-Kalibrierung

1. Nach dem Einstellen der Gesamtfrequenzcharakteristika und der Gesamtverstärkungsregelung das Testband QZZCRA in das Gerät einlegen, und die Aufnahmefunktion (REC/PLAY) einstellen.

— Pegelinstellung —

2. Zuerst auf den REC CAL-Knopf drücken (Die Anzeige "LEVEL CAL" erscheint auf dem FL-Meter)
3. **VR9** so einstellen, daß der Pegel des rechten und linken kanals die Δ -Markierung erreichen, wie gezeigt.

— Bias-Einstellung —

4. Dann den REC CAL-Knopf nochmals drücken ("BIAS CAL" wird auf dem FL-Meter angezeigt.)
5. **VR10** so einstellen, daß der Pegel des rechten und linken kanals die Δ -Markierung erreichen, wie gezeigt.

Anmerkung:

Hinweis Beachten Sie, daß vor der Einstellung von Pegel und Bias die Gesamtfrequenz und die Gesamtverstärkungsregelung eingestellt werden müssen, so daß linker und rechter kanal gleich sind. Andersnfalls treten bei der Einstellung von Pegel und Bias Unterschiede zwischen linken und rechtem kanal auf.

Cassette Deck

RS-B965**DEUTSCH****MESSUNGEN UND EINSTELL METHODEN****Tonkopf-Azimuteinstellung**

1. Spielen Sie auf dem Testband (QZZCFM) den Teil für die Azimuteinstellung (8kHz, -20dB) ab. Drehen Sie die Azimuteinstellschraube so lange, bis die Abgaben des L-K und R-K den Höchstwert erreichen, und die Lissajoscghe wellenfigur sich, wie abgebildet, 0 Grad nähert.

Anmerkung:

When L-K und R-K nicht auf demselben Punkt ihren Höchstwert erreichen, stellen Sie beide Kanäle auf den jeweiligen Höchstwert und gleichen dann aus.

2. Nehmen Sie denselben Einstellvorgang in der Wiedergabestellung vor.

Prüfung des Pegelunterschiedes bei Vorwärts- und Rückwärtsdrehung

3. Den Abschnitt für Verstärkungseinstellung (315Hz, 0dB) des Prüfbandes (QZZCFM) wiedergeben und sicherstellen, daß der Pegelunterschied bei Vorwärts- und Rückwärtsdrehung kleiner als 1dB ist.
4. Nach der Einstellung Schrauben-Sicherungsmittel an die Azimuth-Einstellschraube geben.

Einstellung der Wiedergabeverstärkungsregelung

1. Spielen Sie auf dem Testband (QZZCFM) den Teil für die Einstellung der Verstärkungsregelung (315Hz, 0dB) ab.
2. Stellen Sie VR3 (L-K) [[VR4 (R-K)]] so ein, daß die Abgabe den Normwert erfüllt.

Wiedergabefrequenzaang

1. Spielen Sie auf dem Testband (QZZCFM) den Teil für den Frequenzgang (315Hz, 12,5kHz~63Hz, -20dB) ab.
2. Achten Sie darauf, daß der Frequenzgang für beide Kanäle (L-K, R-K) in dem in Abb.5 gezeigten Bereich liegt.

Wechselstrom-Vorndmagnetisierungseinstellung

1. Das unbespielte Metalltestband (QZZCRZ) einlegen, und das Gerät auf Aufnahme Schalten.
2. L3 (L-CH) (L4 (R-CH)) so einstellen, daß die Ausgangsspannung zwischen TP7 (TP8) und GND geringer als der Minimalwert ist.

Einstellung der Gesamtverstärkungsregelung

1. Legen Sie das normale Leertestband (QZZCRA) ein und stellen das Gerät auf Aufnahme-/Betrieb.
2. Legen Sie ein Bezugseingabesignal (1kHz, -24dB) an. Stellen Sie das Ausgangssignal auf einen Pegel von 0.4V ein.
3. Nehmen Sie das Eingabesignal auf.
4. Geben Sie das in Schritt 3 oben aufgenommene Signal wieder und achten Sie darauf, daß das Ausgangssignal mit dem Normwert übereinstimmt.
5. Sollte der Wert nicht innerhalb der Norm liegen, justieren Sie VR5 (L-K) und VR6 (R-K).
6. Wiederholen Sie die Schritte 2~5 von oben so lange, bis das Ausgangssignal im Normbereich liegt.